

Kirby Hall, Northants

The Evidence of the Masons'  
Marks

Jennifer Alexander 2012



## **KIRBY HALL, Northamptonshire**

### **The Evidence of the Masons' Marks**

Jennifer S. Alexander BA PhD FSA

August 2012

#### **INTRODUCTION**

Kirby Hall is a large stone house built towards the end of the 16th century but modified in several campaigns within the first hundred years of its history and abandoned in the early 19th century. It is laid out in four ranges around a courtyard, with an outer court containing two archways joined by a stone wall in which there is a smaller gateway. Entry into the main courtyard is through the N range. Three of the four courtyard ranges are unroofed and the fourth has a roof over part of the building. Symmetry was an important element in the design of the building and all the courtyard facades are laid out strictly on that principle. The exteriors of the E and S range have both been modified and although the S facade maintains elements of symmetry, the less important E facade displays a lack of uniformity. The greatest change to the building was the replacement of the SW corner with the large-scale State Apartment with its two staircases, which has been dated to the period from c.1580 to c.1620. The interior of the N range was altered as part of this phase, and the E range extended at the rear to provide facilities for the lodgings there. Further campaigns in the 17th century modified the appearance of the N range, on both sides, and added the kitchen stair. Later 17th-century work mainly affected the rear elevation of the S and SW ranges.

The principal building material is coursed rubble limestone, with ashlar used for the courtyard-facing facades, and for the architectural detailing of the rest. The SW range has ashlar used for the S and E walls, and the central section of the N range is also ashlar. Masons' marks can be found on all the dressed stone, although their distribution is not uniform and the 17th-century fabric has the fewest marks. Marks have been cut on the visible faces of the ashlar blocks, and on mouldings of doors and windows, as well as on pilasters, sections of frieze, and staircase handrails. The marks conform to the standard type and are made up of lines

arranged in patterns and there are no compass-drawn examples. Some of the marks consist of more than one element, and can be found used either singly or in combination with a Roman numeral. There is no evidence for the marks acting as assembly marks at Kirby and most examples are regarded as banker marks which were placed on the stone by masons cutting the stone to shape, either as ashlar, or by using a template, with the intention of identifying output for a paymaster. One series of marks may relate to quality control. As has been observed at other sites, the orientation of marks is not important and marks can be found inverted, or reversed, without this being significant. The system stood outside literacy so conventions of orientation do not apply.

The date of the house's construction falls within the start of a period from which there is greater documentation of masons' work, either in the form of building contracts, or on more personal documents relating to property ownership and it is becoming apparent that masons' marks were more closely connected with individual masons at this time than they had been in the middle ages. Masons' marks appear either instead of, or with, masons' signatures on documents and it is now possible to combine this information with other sources to identify masons by their marks. With the background of the additional information being available in some cases it is possible generally to be more confident about the marks being connected to individual masons rather than being more generic, and to use this information to provide links between masons working at different sites. Caution is still necessary, but from the late 16th century onwards it is much more likely that the same marks appearing on two buildings of closely similar date within an area supplied by the same quarries can provide evidence that the same masons were at work. For example, it has previously been suggested, from other evidence, that the 1570s tombs in Fotheringhay church were built by masons who had affinities with the work at Kirby and this view is strengthened by the discovery of at least one of the tomb marks on the windows of the south range at Kirby. Instances of this type are discussed at the end of this report.

## **METHODOLOGY**

All the accessible exterior and interior stonework surfaces of Kirby Hall were examined to discover the extent and nature of the masons' marks on the surfaces by the author with a team of students from Warwick University's Art History department who were financed by the University's Research Studentship Scheme. We inspected all areas of the building which did not require scaffolding, with recording taking place during the day and at night. Conditions varied from bright sunlight, which provided a good natural raking light in the evening, through to heavy rain. Working at night under torch-light made it possible to use a raking light for marks at ground level. In the absence of scaffolding very little information was recovered from the walling at first-floor level on the exterior, although it was possible to record the jambs, mullions and transoms of the upper windows, and certain other areas (for example, see Fig. 3). Marks were recorded on to standardised sheets and site codes allocated to sections and sub-sections of the building so that each occurrence of each mark could be identified precisely to site. All the marked stones were photographed to show the context of the mark in the building, and to show it in detail and the photo numbers entered on the record sheets. The marks were then coded and these codes (Fig. 1a/b), together with the site codes (Fig. 2), entered on to a database which was then interrogated to provide distribution maps of individual and groups of marks. From this it is possible to plot all the occurrences of marks in the building, identify changes in the masons' teams, determine whether certain masons were more specialised in their work than others and contribute to the debate on the changes made to the building.

## **THE CONDITION OF THE STONWORK**

The stone surfaces of the unroofed sections show considerable evidence of weather abrasion and there has been much loss of original surface detail. Interior stonework in roofed sections has evidence both of covering by pigment and of its later removal by abrasive means that has damaged the upper layers of the stone. As a result most of the masons' marks are abraded and in some cases are barely legible. There is no evidence that marks were damaged by the removal of tooling to



provide a smooth finish to the stonework during the construction process. Areas of stone that have been protected by subsequent changes to the building have marks that are much more visible. For example, quoins in the Pallet Chamber that were covered over by plaster, and have since been revealed, have marks that are much crisper, despite being damaged by surface-gouging to provide a key for the plaster.

Marks on the windows are virtually all on the rebate close to the glazing slot and are mainly visible on the windows that have lost their glazing. Most windows that are glazed have mortar over the rebates and any marks there will have been covered up. The building has been in state guardianship since 1930 and had not been inhabited since 1810. Some attempts had apparently been made to prevent further decay of the fabric at the end of the 19th century, but there does not seem to have been a major intervention during the period between. It is clear that some replacement of sections of the Stafford frieze and of parts of the courtyard door lintels has taken place, but the majority of the fabric appears to be original.

Graffiti can be a problem in recording since the presence of masons' marks sometimes provides the inspiration for more casual marks to be made on the stonework, and at Kirby the inner faces of the loggia piers seem to have attracted the attentions of visitors with sharp implements. The graffiti is concentrated at the W end of the inner arcade and it is therefore difficult to extract the masons' marks from the other marks that have been made there.

It is usual when analysing the data to examine the significance of minor differences between marks. This is only done after the marks have been coded and entered into the database. Since this report is limited to those areas of the building accessible without scaffolding the dataset is incomplete and it is therefore premature to try to assess how far minor differences between marks are important, and, except in a few obvious cases, similar marks have not been combined. Results presented here are therefore provisional and should the opportunity arise for detailed study of the upper parts of the ashlar masonry it would be possible to complete the data for the site. The dataset is included as an appendix, presented by mark and by site. Photos

of all the marks are on the disc inside the back cover of the printed version of this report.

## **THE EVIDENCE OF THE MASONS' MARKS**

### **The Courtyard Ranges**

The four ranges around the courtyard share common features and building work started, according to Heward and Taylor, with the S range and continued in a clockwise direction to finish in the SE corner, all within a short period between 1572-5.<sup>1</sup> The evidence of the masons' marks supports the connection between the ranges, with marks shared between them although there is a large number of marks that have only been found in small quantities and some are concentrated in restricted areas. There is a total of 80 different marks found on the four ranges of the courtyard, with another 30 exclusively on the porch. There are four sites where masons' marks can be found, on the plain ashlar and quoins, on window mouldings and embrasures, on the mouldings of the friezes, and on the giant pilasters. The majority survives on the windows.

### **Marks on the Windows**

The jambs of the windows of the S, E and W ranges have been made up of lengths of stone of different sizes, and are not therefore coursed in with the ashlar walls of the courtyard sides, although the depth of the sills of the ground floor windows determined that of the course in which they sit to enable both to be built together with the plinth courses of the ranges. Since very few marks have been found on the sills or on the attached ashlar course it seems probable that these were done ahead of the rest of the windows. The less precise courses of the rubble outer walls of the E and W ranges are also aligned with the window sills, but more approximately.

The ground floor interior window embrasures included ashlar blocks to provide a straight join at the angle with the inner rubble walls of the ranges and were

---

<sup>1</sup> J. Heward and R. Taylor, *The Country Houses of Northamptonshire*, (Swindon 1996), pp. 245-56.



plastered over. Where the plaster has fallen off it is apparent that some of these irregularly sized blocks were marked. The S windows have only two different marks used, 4v8 and 5x11, (Figs 4a and 4b), whereas five different marks occur on the W range, including 24 examples of the mark 11h2 which is only found here (Fig. 4c). The E range retains the plaster on most of its window embrasures on the W side and only two marks have been recorded. The N range embrasures in the western part of the facade, plus the upper eastern window embrasure, share some of the same marks with the S and W ranges, which implies that the embrasures have been retained when the frames of the windows were replaced in the 17th century. No marks were found on the later window frames of the N range.

There is considerable variety in the marks on the original window frames of the four ranges, which is unsurprising as a large group of masons must have worked together to prepare the nearly 60 windows with super-mullions shared between the ranges within the three year period of the first building phase. The marks are widely distributed across the windows. One exception to this is the complex group of marks, 5mt1, 6mt1, 8mt1 and 12mt1, of which the most complete example is 12mt1, (Fig. 4d) which occurs only on windows in the W range. Due to the fragmentary state of the stonework and partial covering by plaster of some examples, it is probable that these marks, that share the same features on their visible sections, are all the same mark.

A few marks are found on windows of more than one range, but it seems more likely that there were separate teams who worked on the moulded stones of the windows for each range and that there was limited mobility between the teams. Mark 18h1 (Fig. 5a), for example is only present on the tall windows at the E end of the S range, although it is possible that the mark may exist under the mortar on the glazed windows at the high end of the Gt Hall, whereas a second mark from the same windows, 4v8, was more widely used (Fig. 4a).

### **Marks on Other Sites on the Courtyard Ranges**

The pilasters around the courtyard and a few sections of the Stafford frieze are marked although the highly decorated pilasters that frame the entrance through the N range do not seem to be. Pilaster marks were usually placed on the fluted face but one of the S range examples is on the side. Marks are shared between the ranges, with the most commonly found mark, 7m5, occurring on all except the S pilasters although they have the fewest marks and one of the two found there is also on the E range. Marks 5av1, which is only found on pilasters, and 7m5 may be the same mark, as they have the same basic form and all the examples of 5av1 are worn. Other occurrences of the pilaster marks are not restricted to moulded work, but occur on ashlar as well. 7m5 is conspicuous for the number of its occurrences and for the fact that it is one of three marks found on the two N facade friezes, where it appears with the related marks 8m6 and 4w2 (Fig. 5 b-d). The frieze panels are thin blocks of plain ashlar, cut separately from the mouldings above and beneath them, and are prominently marked in each case. Two stray marked blocks from the frieze have been reused in the interior walling of the N range (Fig. 5b). The frieze is described by Heward and Taylor as having been retained when the N facade was remodelled and the presence of 7m5 on the 16th-century masonry next to window NN0.5, and on an upper quoin to the W side of the gateway, as well as on the frieze, confirms its role in the original phase.

### **Porch**

Masons' marks are present on a large number of the blocks on the interior and exterior walls of the porch, with the exceptions of the outer and inner entrances, although the inner face of the N wall does have marks. The exterior level of the upper walls was examined, but the interior of the porch chamber was not accessible. A total of 37 different marks has been recorded from the porch, of which only seven appear elsewhere in the building. The marks form a distinct group and this is the only place that there is a concentration of stones on which Roman numerals were used, and where double-marking appears.



Roman numerals are frequently found at other sites where it has been observed that the marks rarely conform to the practice of putting I before a V or X for the numbers 4 or 9, and instead IIII or VIII is used for clarity, and to avoid confusion with the numbers 6 and 11. The same occurs here, and it is assumed that IIIV is meant to be read as 8, and not as an unusual way of writing 2. There are gaps in the sequence which starts at 4, and it is only continuous from 7-15. It is therefore unlikely that there is any numerical significance in the sequence (Fig. 6).

The double-marked stones can be read as four groups, based on the mark used with the numerals; the 4w2 group has two marks, 9wp1 and 9wp2, which include 4w2 with another element, and occurs on the N porch wall, the 3h3 group of two marks is on the E exterior wall, the 3gv1 group, consisting of 10 different marks, is mostly seen on both faces of the W wall with a few examples on the E interior wall, but none on its exterior, and the 5x11 group is found on all the porch walls. It is made up of 9 distinct marks. The marks 4w2 and 5x11 are also found on their own on other parts of the building, but not on the porch, whereas 3h3 and 3gv1 only occur on the porch.

It is not apparent what purpose the double-marking serves, there is no evidence that the numerals relate to the numbers of the courses, or that they form a coherent sequence related to their site. An alternative suggestion is that they are connected with a rebuilding of the porch and that they represent a coded means of identifying where the blocks were in the original walls, although the presence of a few further double-marked blocks on the other ranges makes this seem less likely. It is more probable that the double-marking served as a quality control, with the second mark showing that the stone had been inspected and passed by another mason. It is noticeable that only three of the double-marked blocks appear at first-floor level on the porch's exterior and it would be valuable to inspect the interior walls of the upper level should the means of access become available in the future. Despite this uncertainty of the purpose of the double-marking, it remains significant that the porch is the only part of the building on which this occurs consistently, and it suggests that the porch was a separate project in the building works.

The double-marked stones that are not in the porch are mostly found in the end of the E range closest to the SE corner or on the S range and, if the sequence of construction is as described by Heward and Taylor, then it would seem that the porch was raised as the final part of the courtyard project, after the S range, although the date of 1572 over the entrance implies that it was planned from the start. Of the seven porch marks found elsewhere in the building, two marks are from the first-floor level on the exterior; 4h1 is on two windows in the other ranges, and 6p7 is found in bay 2 of the courtyard side of the E range. Two of the other marks, plus two related marks, can also be found on the gates of the outer court and this will be returned to.

### **Marks on the SW Range**

The rebuilding of the SW range to create the State Apartment has been placed in the second phase, under Christopher Hatton I, and started only five years after the completion of the main fabric of the courtyard ranges. The phase is thought to have lasted for around forty years and to have been completed by c.1620. It is clear from the masons' marks that there were changes in personnel between 1575 and the start of the new work in 1580 but not a complete replacement of masons, and although some of the marks on the State Apartments are different to those of the rest of the site, a certain number of marks are shared. Overall, of the approximately 137 different marks found at Kirby, only 32 are on the SW range, but more than a half of those are retained from the first phase. Most of the marks have been recorded from the windows, door frames and architectural elements from the range, but marks are also present on the ashlar. The interior, where the walling is exposed, is mostly constructed of coursed rubble, with occasional ashlar blocks inset, some of which have marks. It might be expected that some of these blocks would have been re-used from the earlier structure, but the marks reveal them to be from the post-1580 phase. This is also true for the marks on the quoins of the Pallet Chamber E wall, although it might have been thought that some at least of the complex sequence of building breaks there would have related to the previous phase. The exterior marks show up under a raking light, but are hard to see under



natural light, and as a result it was only possible to locate ground-floor marks. The condition of the stonework is sufficiently good for marks to survive at a higher level and it is recommended that inspection of the upper levels is carried out in the future.

There is a consistency in the marks throughout the State Apartment, with no evidence that it was built over a long period. There are a number of changes visible in sections of the building, and it is clear from the almost total absence of marks from the Gt Parlour and its upper Gt Chamber that this section has to be regarded separately. The discovery of the foundations of a third bay window on the exterior of its S wall, and the lack of any evidence for it in the standing fabric suggest that there has been a considerable replanning of this part.<sup>2</sup> The one place that marks occur in the Gt Chamber is on the side of the window frame nearest to the head of the Gt Stair and it is plausible to suggest that it was built as part of the corner of the stair.

The similar lack of marks from the windows on the W wall of the Library and small chambers off it can be attributed to the changes to the windows visible in the fabric, since this must have happened during a phase when masons were not required to mark their work. It is evident, however, that the masons who cut the stone for the two standing bay windows were part of the same team that worked on the rest of the State Apartment, and that the windows were not an addition. There are no marks on the lower lights added in the modification of the windows when the sills were lowered.

The work of the State Apartment was linked closely to the existing work of the W range, with the same coursed rubble used for the W side of the new work, and decorative gables were added to the W range above the plain parapet as part of the scheme. A narrow fluted band was also inserted into the masonry above the ground and first floor windows and extended across the whole of the W elevation to finish

---

<sup>2</sup> Brian Dix, Iain Soden and Tora Hylton, 'Kirby Hall and its gardens: excavations 1987-1994', *Archaeological Journal* 152 (1995), pp. 291-380.

at the SW corner of the Library, but it was changed at the corner of the N and W walls of the Gt Stair and the upper frieze was left plain for the rest of the range. Three marks have been found on the frieze and are those of masons who worked primarily on the State Apartment, and are sited close together in the corner between the lesser stair and the Pallet Chamber window. A different one was found on the section further N, and none of the masons were the same as those who carved sections of the Stafford frieze.

It is possible to comment on the period on site for some of the masons. 4v8, for example, was responsible for a considerable amount of work on the window frames of the W and S ranges in the first phase, but his mark is only found on two pieces of window frame in the State Apartments, suggesting that although he returned for the second phase, he did not remain. 3a6 had worked on the courtyard pilasters and on ashlar for the first phase, but only produced part of one door frame in the lobby of the Gt Stair in the second phase and then appears to have left the site. The door frame shares the same unusual design of inverted obelisks, and exactly the same offset in the blocks for lintel and cornice as the adjacent door at the foot of the Gt Stair, but they were produced by different masons. 3a6 had worked with 4b20 on the lobby door into the W range, but 4b20 was joined by three different masons for the adjacent door at the foot of the Gt Stair, presumably because 3a6 had left.

The siting of some of the new marks is revealing. 4q7 arrived for the second phase and his mark is present from the cellar to the attic of the State Apartment, and on the handrail of the Gt Stair. The mark is particularly associated with the S and E parts of the State Apartment, around the western of the bay windows and on the return wall to the E, but not on the SE bay window, and its presence on the blocking of the cellar window under the Library demonstrates that the windows were always closed off. 4q7 is also on the E courtyard range, but only on those sections connected to the remodelling of the E side in the second phase (Fig. 3). Similarly, mark 6a30, which is on the Pallet Chamber W window, and on the Gt Stair handrail, can also be found on the extension to the E range, on the partially blocked three-light upper window and on the quoins. 4q7 and 6v82 are on the quoins of the

chimney on the rear wall of the Gt Hall, but since neither mark is present in the first phase, in which it is placed, it suggests that the chimney was altered at this time.

An important part of the second phase was the construction of two staircases to provide access to the upper parts of the State Apartment. Each has a moulded stone handrail built into the staircase wall, on both sides of the Gt Stair and on one wall of the Lesser Stair. Marks can be found on both sites, made by a team of 10 masons, eight of whom only appear in the second phase. There was little mixing between the teams with only one mason, 11h1, working on handrails for both stairs. 13 sections of the Gt Stair rail are marked and only three of the Lesser Stair. Staircases were added in the N range at this date, and given stone handrails of the same design, but only one mark survives there and it is not from the same team. The handrail masons worked on a variety of other types of work on the site as well, primarily moulded work although six also cut ashlar blocks. The two masons in the team who were retained from the first phase had both been engaged in template work in the first phase and cut ashlar in the second but since the moulded work is fairly straightforward at Kirby there was probably little distinction in the work.

The mark 11h1 is only found on moulded work and resembles 11h2 which is found on the embrasures of the W range windows exclusively and it raises the question of the significance of the differences between marks since both marks have a similar form. 11h2 is a small mark with the main strokes deeply cut and the additional strokes are a minor element of the mark. By contrast 11h1 is invariably lightly incised and the end strokes are proportionally larger (Fig. 7). Since the marks were cut freehand it is to be expected that there will be variation in their scale, and not all blocks of stone have the same cutting properties, so marks will not always be cut to the same depth or in quite the same way. The consistency of the difference between 11h1 and 11h2 would lead to the conclusion, however, that either they were the work of different masons, or that they belong to different periods. 11h1 can also be found at a number of other sites in the region, in buildings that are dated from 1578 (Rothwell Market House) to 1622-24 (Apethorpe Hall) whereas

11h2 has only been found at Kirby and it would therefore seem that the two marks belong to two different masons.

The two-storied passage off the Gt Hall is a complex part of the building with several phases. It was originally built to provide a well-lit chamber at two levels off other rooms and became a passage when its ground floor windows were altered and it was extended to provide access to the Pallet Chamber. The large four-light window on the E side was blocked twice, firstly to reduce it to two lights and finally to close it off completely. It does not appear to have marks, but it is currently obscured by a plaster wall and cannot be accessed. The S window and its embrasure may well have been re-used from the original S wall and has one marked stone with a mark from the post-1580 phase. The numbering of the blocks on the W embrasure probably relates to a dismantling of the walling during conservation work in the 20th century. The S facing window on the first floor, which is in situ, has the mark 4v8, and this belongs to an early part of the post-1580 phase. On the exterior, mark 4q7 is found on the first phase of work on the State Apartment, on a quoin at cellar level and on the ground floor wall in the corner beyond the site of the blocked four-light window. The passage may have functioned as a masons' workshop during building work, see further below.

The entrance to the passage is through a plain doorway from the Gt Hall that has clearly been broken through an existing wall. The walling just inside the passage is ashlar and is dated by the presence of a double-marked stone, related to the porch ashlar, and including the mark 4r1 which can be found otherwise on a window frame from the W range from the 1572-5 phase and on two ground-floor windows of the State Apartment, and is probably therefore from an early part of the post-1580 phase.

### **The Outer Court Gateways**

Two stone arches of the same design close off the carriage drive to the house from E and W. Each is a single large arch with a dropped keystone under a stone hipped cresting with heavy finials, flanked by two levels of hollow niches with slender



pilasters. The two sides of the arches are virtually the same and masons' marks survive on the stonework, particularly in the niches where there has been greater protection from the weather. The arches are usually compared to those of Holdenby House which share a similar design of a large arch flanked by niches and are dated 1583 by plaques.

There are fifteen different marks on the E gate and 8 on the W gate, with only two found on both, which means that a team of at least 21 masons worked on the gates. Over two-thirds of the marks are new to the site, and not found on the rest of the building which suggests that the gates belong to a different period, although one not much later in date. The six marks from the earlier parts of the site include two from the second, post-1580 phase, 4q7 and 6a31, and four from the first phase that do not appear in the second. Two of these are porch marks, and one of the marks only found on the gates, 8vx1, is a related mark which consists of two elements including a Roman numeral. It would seem that these were masons who were called back to the site for this project.

An alternative suggestion is that the gates were prepared at the same time as the second phase, but by a group of masons who were largely distinct from the main group although the gates would not have required masons of any greater competence to produce them. The presence amongst the gate masons of several whose marks have been found elsewhere does provide an alternative interpretation. The very distinctive mark, 5t6 is also found on the fireplace in Deene Park that commemorates the 1605 marriage between the Brudenell and Tresham families (Fig. 8a). It occurs as well, with 6w10, (Fig. 8b) on the 1622-24 range at Apethorpe Hall, together with 13h1, which has now been identified as the mark of Samson Frisby (1597-c.1656). A later date is therefore suggested for the Kirby gates, after those of Holdenby, probably in the early 17th century.

#### **GEOMETRIC DRAWINGS**

Apart from a few single compass drawn circles of a type commonly made by masons testing their tools, for example, on the inner E wall of the porch, there are

two examples of masonic geometric drawings (Fig. 9). The window sill of EW0.5 of the E range has a set of concentric semi-circles inscribed upon it, with radii of between 3.25 and 6.25cm (c.1.25 to 2.5 ins), that may have been used as a reference point and it was probably done in situ. Stones in the wall at the entrance to the passage off the Gt Hall may also have functioned in a similar way. One consists of a ruled figure approximating to a square inset within a second square. The inner square measures 29.5 by 28.5cm with the outer 34 by 34cm (c.11.5 by 11.25 ins and 13.5 ins by 13.5 ins) and there is a prominent pair of masons' marks in the centre. The pairs of lines extend beyond the square to the right, and one line of the inner square continues across the entire height of the next stone on which are inscribed several compass-drawn circles and arcs, and on to the stone above. The corners of the square are accurate right-angles and will have been drawn against a former. It must have functioned as a type of grid from which right-angles could have been taken and small designs worked out in temporary media such as chalk or similar. Parts of the floor in the passage are flagged and it would be worth clearing out this area and testing to see whether further drawings exist on the floor, or on the walls were the plaster to be removed, in which case it could be suggested that it functioned as a workshop for masons. The inscribed stones have been pierced for panel-fixings and this suggests that the marks were made before the passage was finished.

#### **RELATIONSHIP BETWEEN THE MARKS AT KIRBY AND AT OTHER SITES**

Kirby Hall is close to several other buildings that were under construction during a similar period and these were briefly examined to see whether their marks were related to the Kirby examples. Rushton Hall, in building c.1595, has a series of marks which include some also found at Apethorpe Hall but no Kirby marks, although one example of a Roman numeral mark was found there. Rushton Triangular Lodge, dated 1594-7, was built by a separate team of masons but it includes three possible Kirby masons, 4h1, whose work has only been found in the first phase at Kirby, 3m10, who cut two stones there, and 3b10. Rothwell Market House, dated by contract to 1578 has a couple of ashlar blocks with double-

marking including Roman numerals, although the accompanying marks are not Kirby marks, but it does have the mark 11h1 on the voussoirs of the ground floor arches.

As noted above, there is a particular connection with the 1622-24 range at Apethorpe Hall. Marks 11h1, 13h1, 5t6, 6a30 and 6w10 are shared between the two, and the less-distinctive marks 3b10, 3h1, 4m1, 4w2, are also present at both sites. The quarry-master Thomas Thorpe has been linked to Apethorpe and it seems probable that his masons were also involved at Kirby. This would be a fruitful line of enquiry to pursue, in which other buildings from the period that used the stone quarried in the region might also be included.

Finally, mark 18h1, from the tall windows at the service end of the Gt Hall, is also found on the tomb of Richard, duke of York from 1572 in Fotheringhay church, which has been attributed to the masons employed by Edmund Brudenell at Deene Park who had also worked at Kirby.<sup>3</sup> Mark 4w2 is on the second 1572 tomb at Fotheringhay, to Edward, duke of York, but this is a very common mark and it would be unwise to claim it as a Kirby mark.

## CONCLUSION

Despite the weathered condition of the stonework at Kirby Hall it is still possible to find masons' marks on the surfaces of ashlar and moulded stone. The absence of a large-scale restoration project in the 19th-century has probably spared a great deal of the original masonry, and its situation as a ruined rather than inhabited structure has presented more material for examination than would have been possible in a house in use. The marks were placed on visible surfaces and would have been seen in daylight although they were not so deeply cut as to have been obvious to a casual glance. It is unfortunate that the main fireplaces have not survived since marks that have been recorded at other sites on the elaborate architectural fire surrounds and over-mantles have provided valuable information

---

<sup>3</sup> Sofija Matich and Jennifer S. Alexander, 'Creating and Recreating the Yorkist Tombs in Fotheringhay Church', *Church Monuments* 26 (2011), pp. 82-103.

about the allocation of work within the works department of great houses. None of the moulded work at Kirby is of a particularly sophisticated nature, with the exception of the facade of the porch into the Gt Hall, and the two most ornate pilasters on the N range, but neither of these appears to be marked. Closer examination of the facade of the porch at a higher level would provide more conclusive evidence. Those apart, it would not have been necessary to distinguish between the work of ashlar masons and those who worked from templates to cut moulded work and the same marks occur on both types of work. The Stafford frieze on the courtyard ranges is more skilled work, but it was evidently within the capability of the masons within the team who otherwise worked on the more usual items of ashlar and moulded stone for window frames.

The evidence of the marks broadly supports the phasing of the building proposed by Heward and Taylor, in which the four ranges of the courtyard belong to a single campaign of short duration, although it is clear that the porch was not built with the S range but as a separate project and probably at the end of the 1572-5 period.

The second phase, the State Apartment, followed on after a break and most of the masons were paid off, but over half the team needed for the new work was drawn from the men who had worked on the first phase and so the break is unlikely to have been a long one. It is interesting to note that the remodelling of the exterior of the E range to improve the lodgings there was done by the masons of the second phase, and this confirms its date. Later alterations in the fabric are less easy to assess from the marks, since they are not present in any quantity in the 17th-century work. Only one mark can be seen, for example, on the stonework of the gateway added during Nicholas Stone's period at Kirby, mark 6x10, which is high up at the level of the roof parapet. The gateways in the outer courtyard were built by a team of masons who had mostly been recruited as new men, but included a few that had already worked on the site. Two were masons whose marks are prominently displayed on the frieze of the N range. Amongst the new men are several whose work can be seen at more closely dated sites in the region, and from



this it is possible to suggest an approximate date for the work in the early 17th century.

It is evident from other sites that later 17th-century masons did mark their work on the exposed faces of the block and the low number of marks here may be attributed to one of two reasons. Either the masons were paid regular wages, in which case there was no need to identify output, or the choice was made to mark only those faces of the stone that would not be visible in the final structure. These were the sorts of decision that were made by the supervising foreman within the masons' team, and reflected workshop practice at a given time. In a house-building project the masons would have probably been recruited from a quarry area, such as that around the Weldon quarries, with a master chosen who would have brought in his own team of skilled masons. During the period after the Reformation masons would more and more have been trained at the quarry rather than on a site since the workshops of the middle ages which were based around the great churches would no longer have been in operation.

Master masons, rather than architects in the modern sense, still ran the projects, designing the buildings and organising the supply of labour materials and acted much as their medieval forebears had done. Many of the traditional methods used on the medieval sites continued to be used in the period up to the 18th century, including the display of masons' marks. The difference is that once the early-modern period had arrived, a change had taken place, and masons' marks had become much more closely associated with named masons. The reasons for this are complex, but the greater survival of documents related to building works from c.1550 onwards enables closer connections to be made between marks and individual masons.

Detailed study of masons' marks on great houses, as opposed to those on medieval churches and cathedrals, is still a new discipline, but it can be used to test theories of phasing proposed by traditional means and has the potential to add further information to the debate about the working methods of the men who built the houses. Kirby Hall is a particularly interesting site to study since it is a building of

several phases with a considerable amount of fabric accessible, and it is to be hoped that the upper parts of the building will become available for inspection in the future so that this study may be concluded.

							
1b3	2b1	2d1	2t5	2t33	2v1	2v2	2v12
							
2x1	3a1	3a2	3a13	3a4	3a6	3a46	3a50
							
3b10	3gv1	3h1	3h3	3h15	3h30	3L1	3m10
							
3q2	3s1	3t15	3t16	3t17	3v10	3x17	3y1
							
3z50	3z51	4a1	4a2	4a3	4b1	4b10	4b20
							
4b22	4b24	4bq1	4f1	4g9	4g10	4gv1	4h1
							
4m1	4m5	4m10	4m23	4p7	4p12	4pd1	4q2
							
4q7	4r1	4r4	4t7	4v8	4v20	4w1	4w2
							
4w3	4z15	5a1	5a6	5a11	5av1	5b4	5eh1

Fig. 1a Kirby Hall Masons' Mark Codes

































































							
5f55	5gv2	5m2	5p13	5mt1	5t6	5v9	5v10
							
5x11	6a3	6a30	6a31	6a42	6av1	6gv9	6gv11
							
6gv20	6p7	6mt1	6q1	6v82	6w10	6x10	6x11
							
6xt1	7ah1	7gv4	7gv14	7m5	7h24	7p5	7t2
							
7vh1	7x7	7x10	7xy1	8gv7	8gv8	8m6	8mt1
							
8vj1	8vx1	8x3	8x11	9gv6	9wp1	9wp2	9x10
							
9x12	10ap1	10h1	10rp1	10tt1	10x1	10x8	10x13
							
11h1	11h2	11x14	11xp9	12mt1	13h1	15h1	18h1

Fig. 1b Kirby Hall Masons' Mark Codes



Fig. 2 Kirby Hall Site Codes

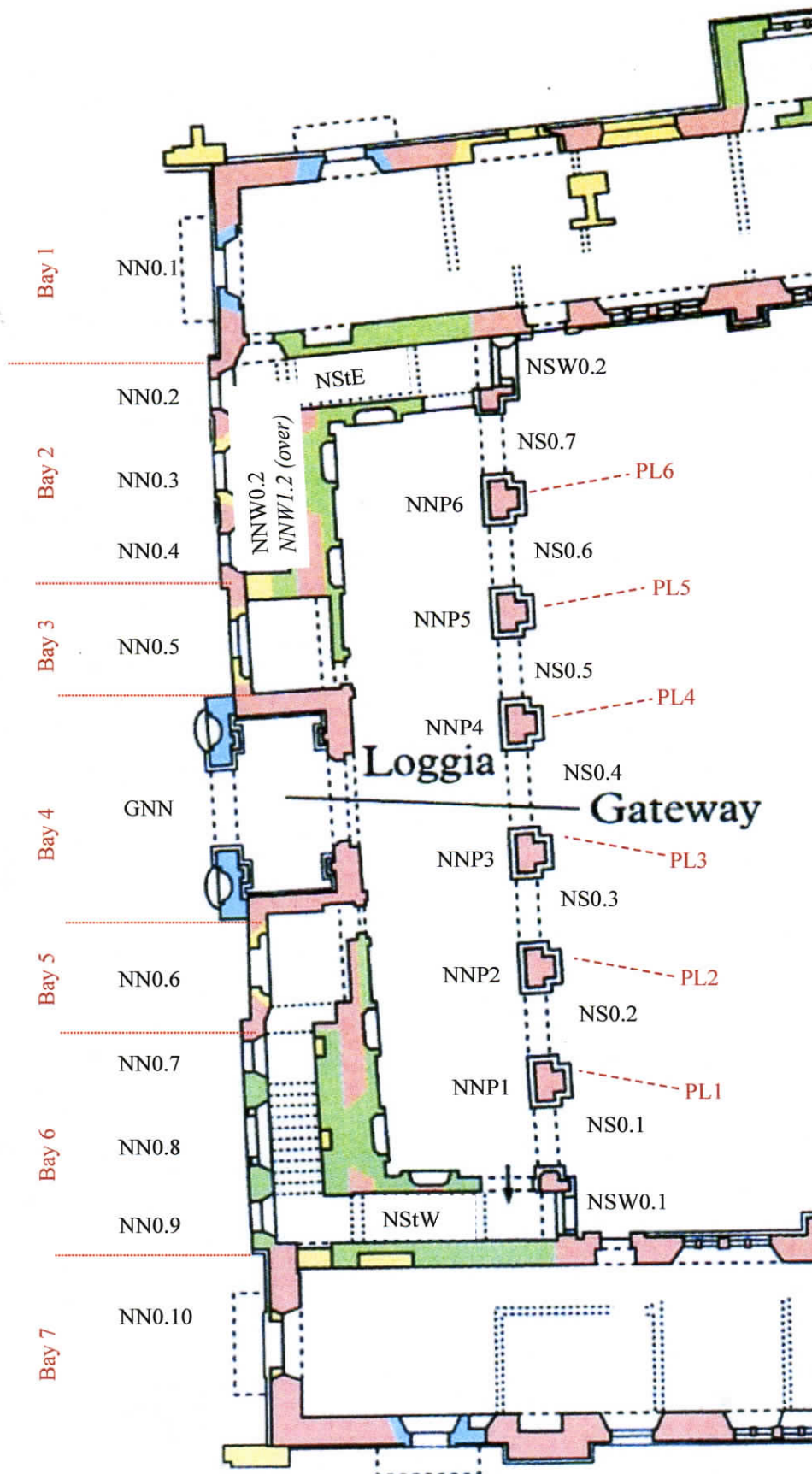

NORTH RANGE SITE CODES. Upper windows on the N façade are coded NN1.0 to NN1.10

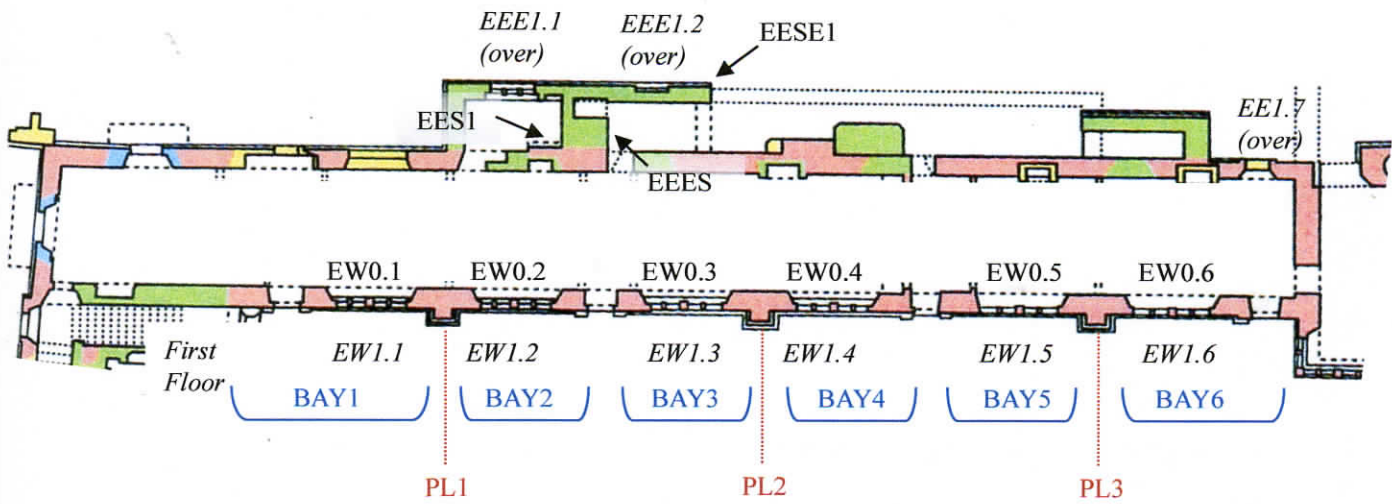

EAST RANGE SITE CODES

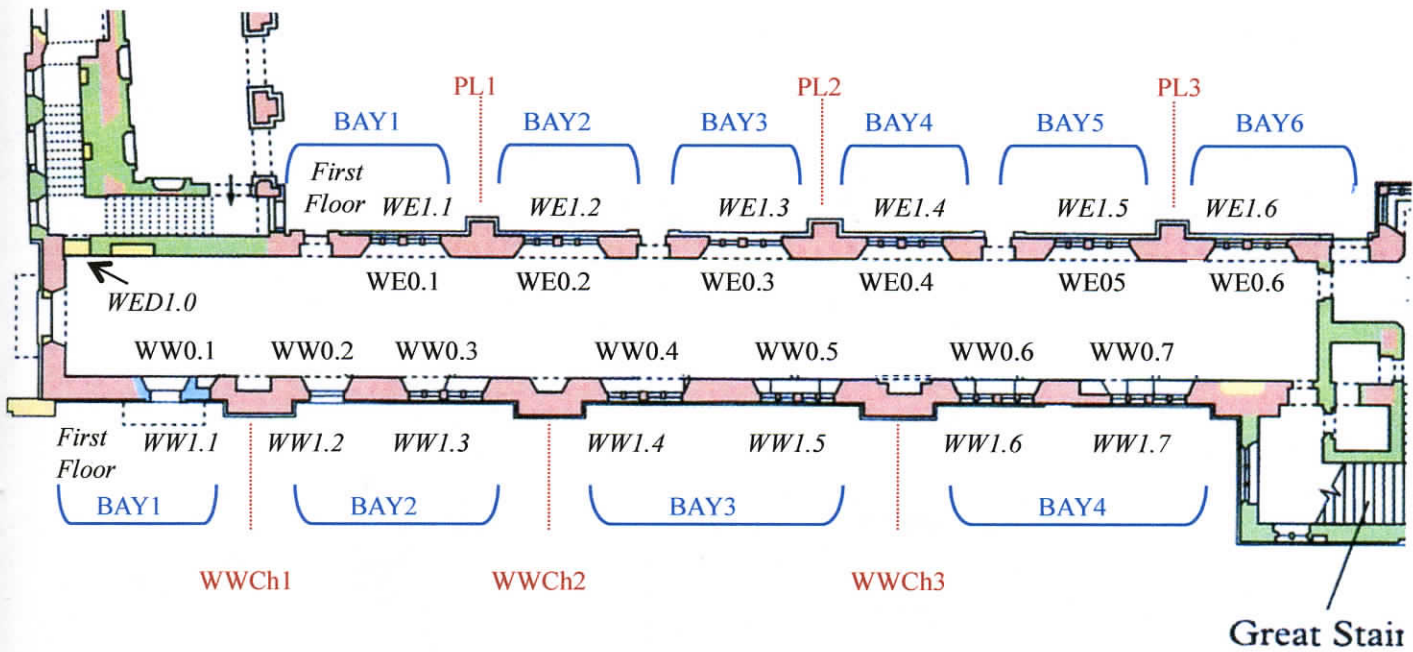

WEST RANGE SITE CODES

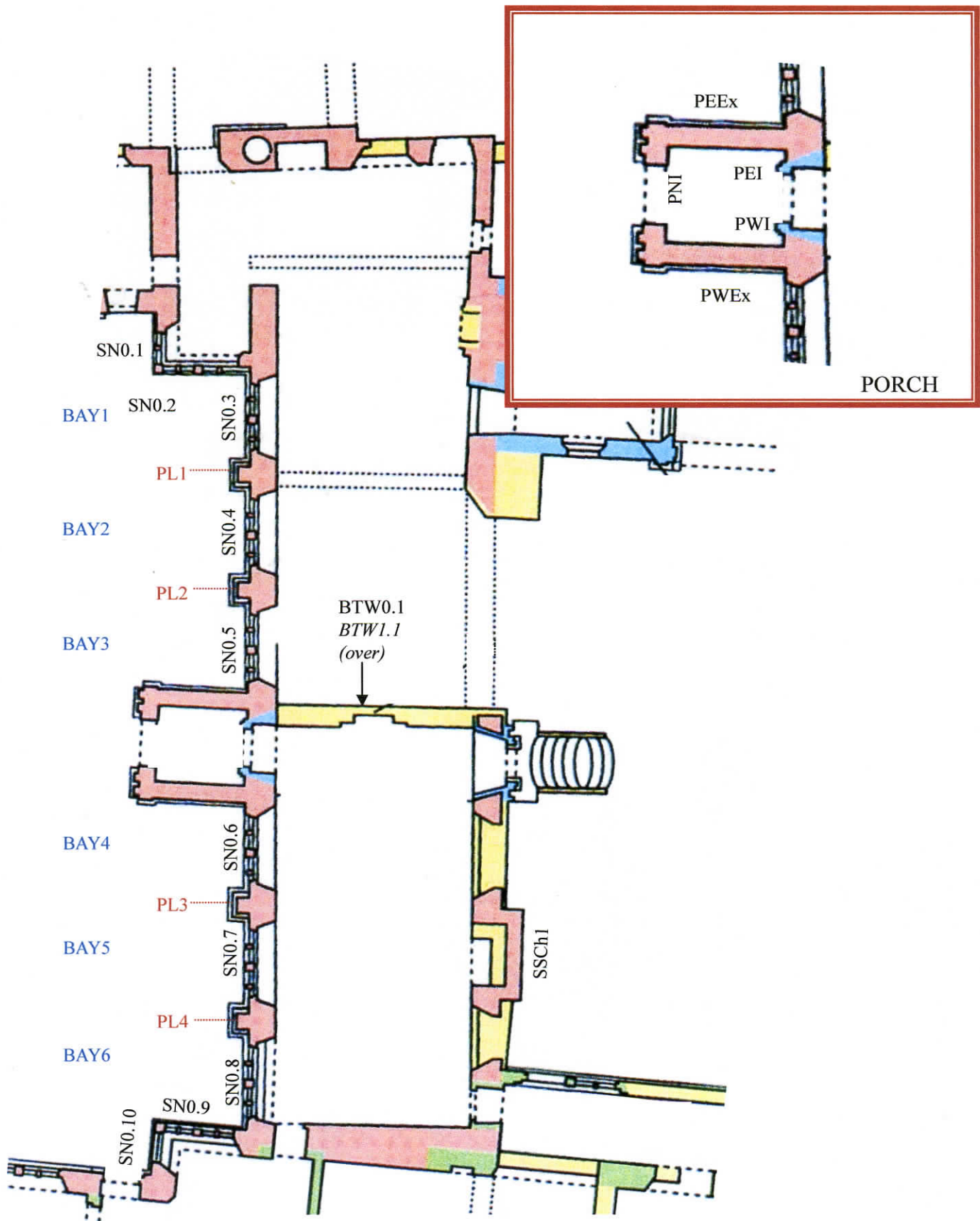

SOUTH RANGE MARK CODES, WITH PORCH INSET UPPER RIGHT



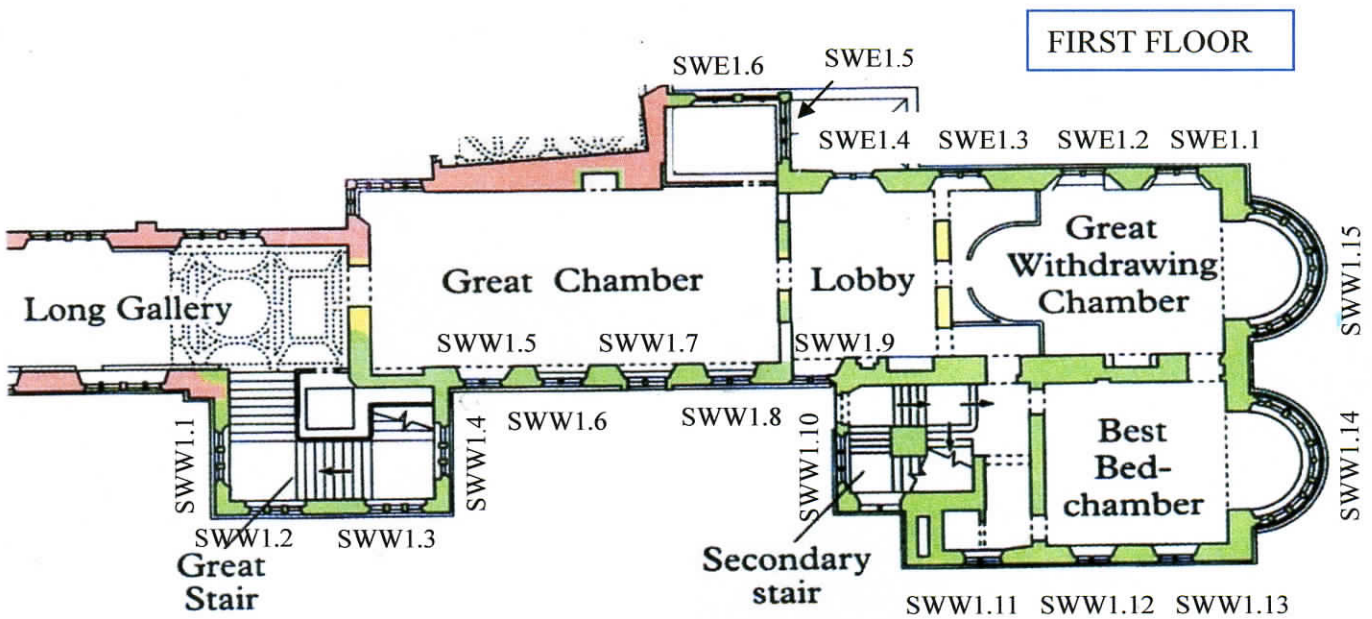
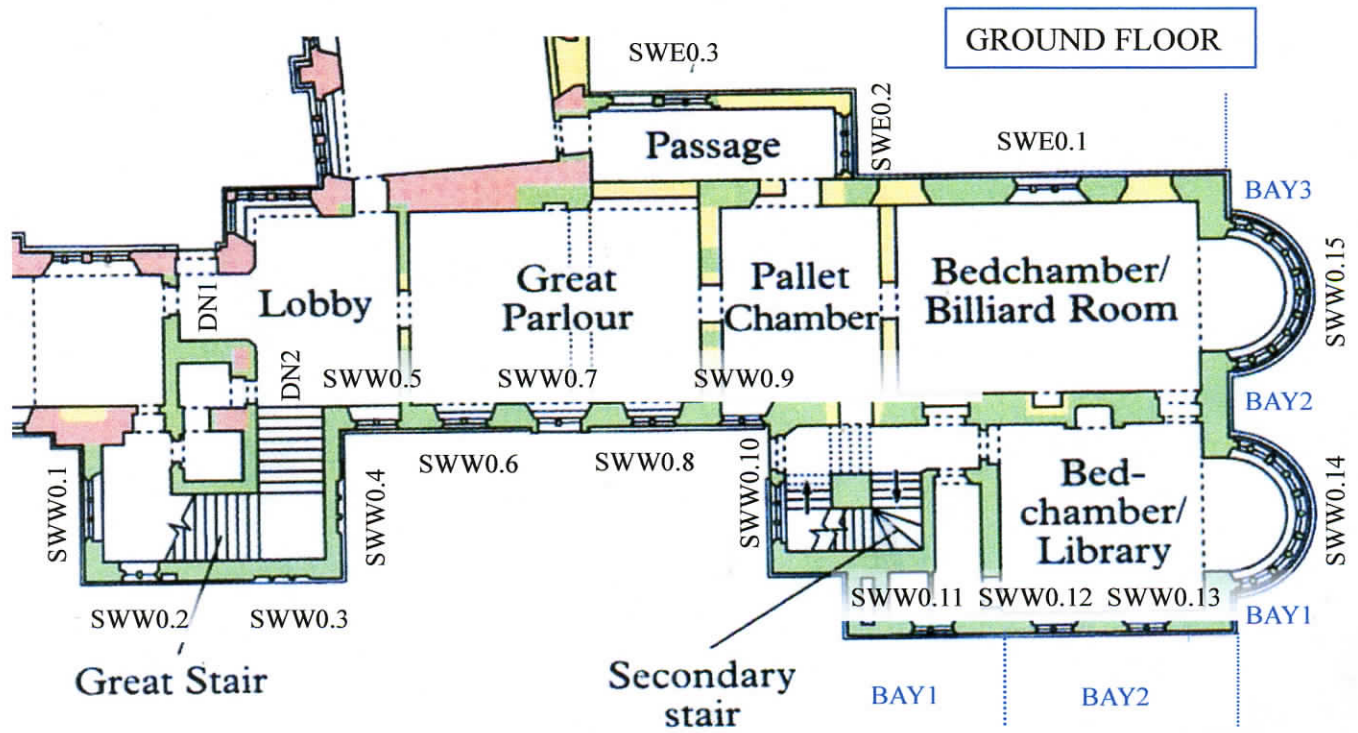

**STATE APARTMENT SITE CODES**

For the Great and Lesser Stairs the codes F1-4 refer to the flights of the stairs and L1-4 to the landings, with compass points to identify walls. Cellar codes follow ground floor codes and Attic codes follow those of the first floor



Fig. 3 East Range,  
south end, mark 4q7  
on site EES1







a) 4v8

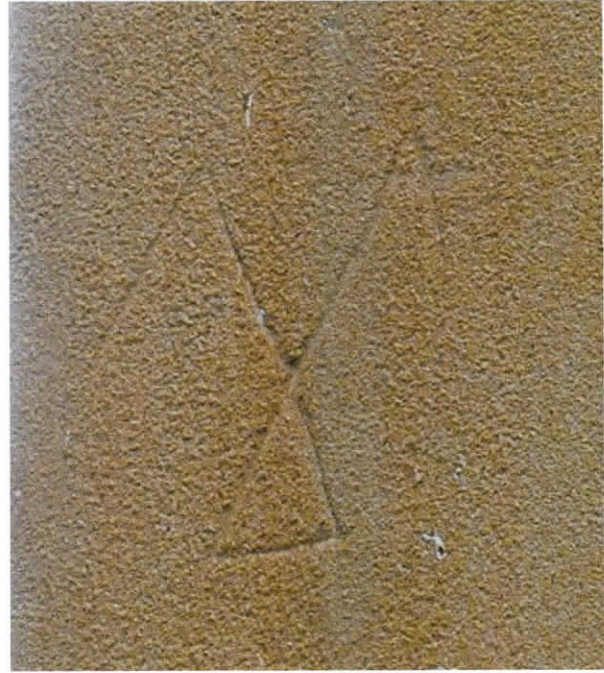

b) 5x11



c) 11h2



d) 12mt1

Fig. 4



Fig. 5

a) 18h1



b) 7m5 on reused frieze panel



c) 7m5 on frieze

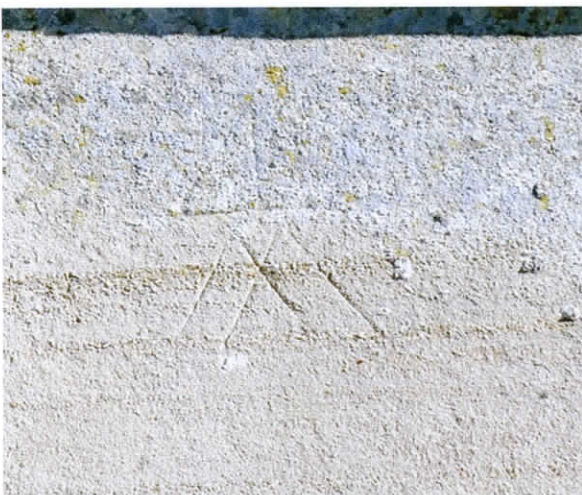

d) 8m6 on frieze





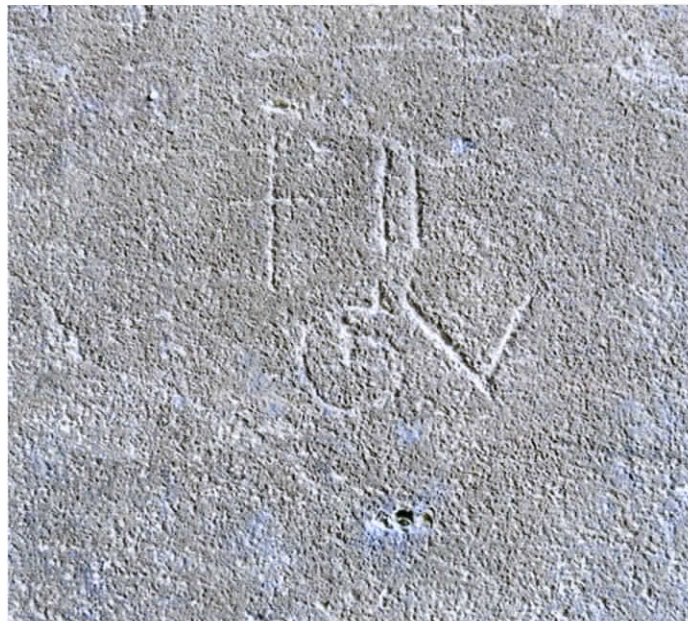
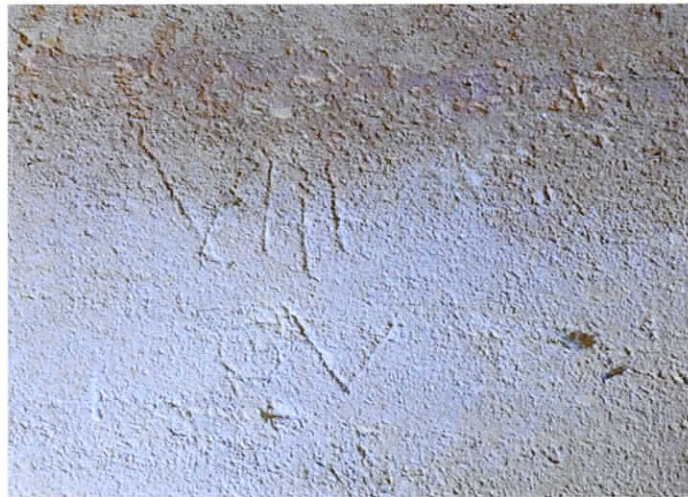

Fig. 6 Marks 11x14, 8gv8 and 7gv14 from the porch



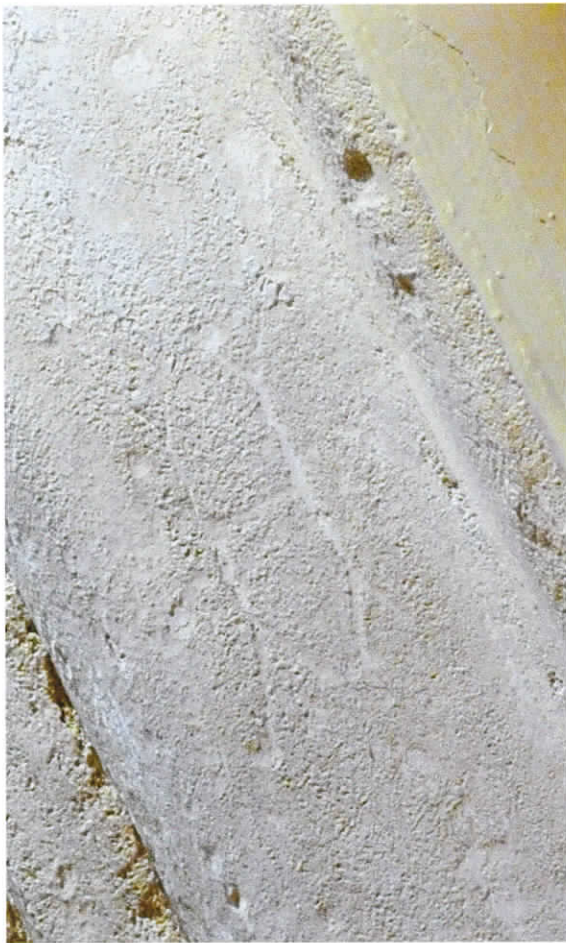

Fig. 7 Marks 11h1, *upper*, and 11h2, *lower*





a) Mark 5t6 on the E gate at Kirby Hall, *left* and at Deene Park, *right*



b) Mark 6w10 on the W gate at Kirby Hall, *left*, and at Apethorpe Hall, *right*

Fig. 8



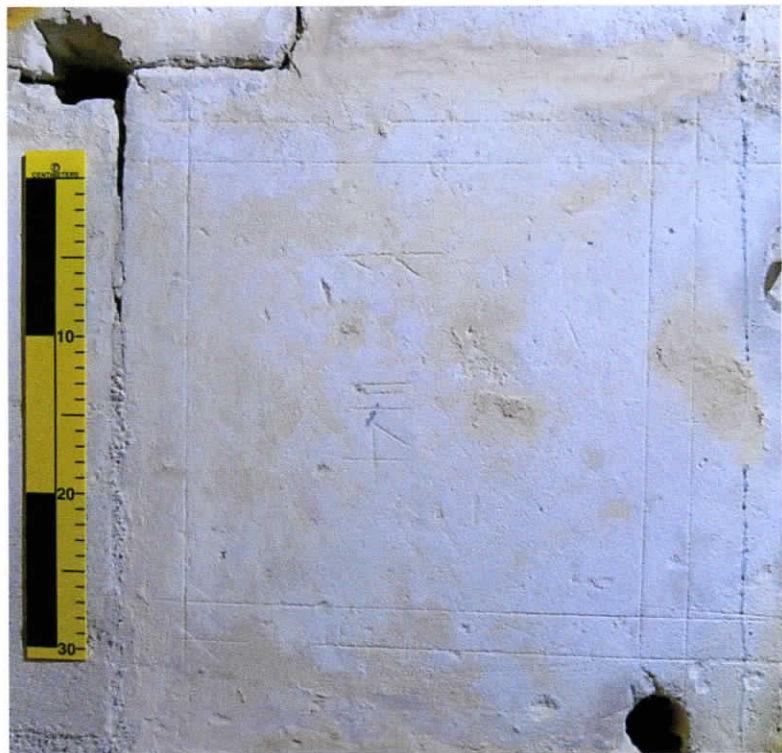
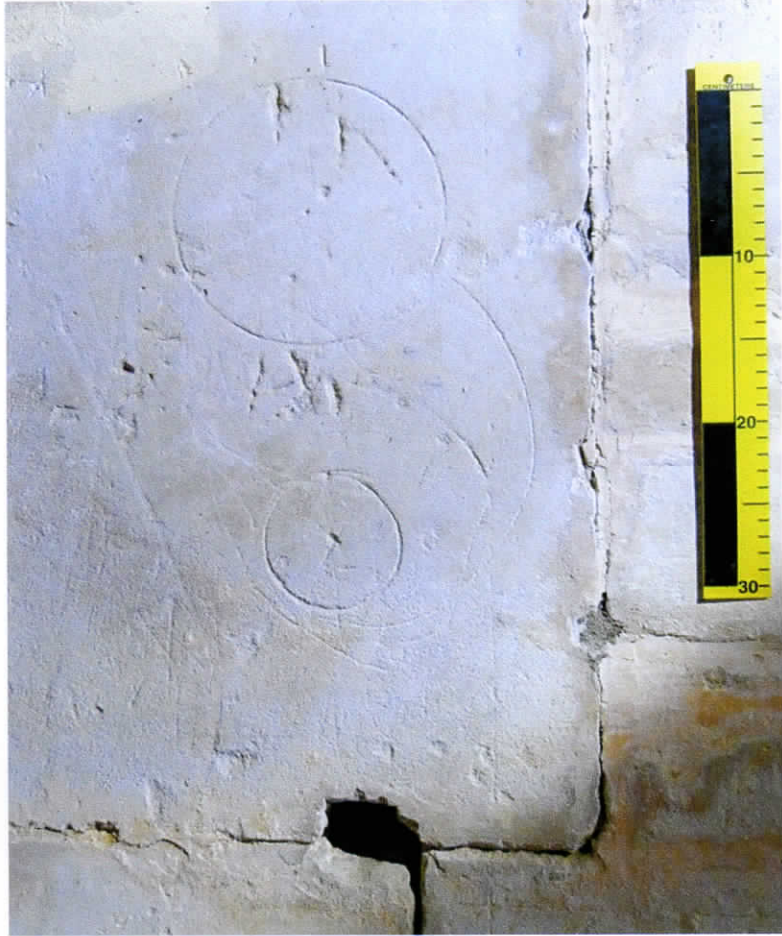

Fig. 9 Geometric drawings from E range window EW0.5, *above*, and SW range passage, *right, upper and lower*

Appendix: Data sorted by Zone and by Mark

KH Zone	Level	Zone 2	Feature 1	Feature2	Feature 3	Feature 4	Surface	Crse	Stone	Mark	Orient.	Cond.
N Range												
Stair E												
N Range	one	Stair E	rail	NStE	W side		rear	3	1	4z15	angl	worn
N side												
N Range	one	N side	frieze	bay1	centre		face	1	1	7m5	inv	worn
N Range	one	N side	frieze	bay1	centre		face	1	9	7m5	inv	worn
N Range	one	N side	frieze	bay1	centre		face	1	11	7m5	inv	worn
N Range	one	N side	frieze	bay2	centre		face	1	14	4w2	inv	worn
N Range	one	N side	frieze	bay2	centre		face	1	13	4w2	up	worn
N Range	one	N side	frieze	bay2	centre		face	1	16	7m5	up	worn
N Range	one	N side	frieze	bay2	centre		face	1	17	7m5	up	worn
N Range	one	N side	frieze	bay2	centre		face	1	19	7m5	up	clear
N Range	one	N side	frieze	bay2	centre		face	1	12	8m6	up	clear
N Range	one	N side	frieze	bay2	centre		face	1	15	8m6	up	clear
N Range	one	N side	frieze	bay2	centre		face	1	18	8m6	up	clear
N Range	one	N side	frieze	bay2	centre		face	1	20	8m6	inv	worn
N Range	one	N side	frieze	bay3	centre		face	1	22	4w2	inv	worn
N Range	one	N side	frieze	bay3	centre		face	1	23	4w2	up	worn
N Range	one	N side	wall	bay3	W side		face	9		7m5	up	clear
N Range	one	N side	frieze	bay3	centre		face	1	24	7m5	inv	clear
N Range	one	N side	frieze	bay5	centre		face	1	2	7m5	inv	worn
N Range	one	N side	frieze	bay5	centre		face	1	3	8m6	up	clear
N Range	one	N side	frieze	bay6	centre		face	1	9	7m5	inv	worn
N Range	one	N side	frieze	bay6	centre		face	1	4	7m5	up	worn
N Range	one	N side	frieze	bay6	centre		face	1	10	7m5	up	clear
N Range	one	N side	frieze	bay6	centre		face	1	11	7m5	up	worn
N Range	one	N side	frieze	bay6	centre		face	1	12	7m5	up	clear
N Range	one	N side	frieze	bay6	centre		face	1	8	8m6	up	worn
N Range	one	N side	frieze	bay6	centre		face	1	13	8m6	up	clear
N Range	one	N side	frieze	bay6	centre		face	1	14	8m6	up	clear
N Range	one	N side	frieze	bay7	brket3-4		face	1	1	7m5	up	clear
N Range	one	N side	wndw	NN0.6	embrE		face	1	1	2b1	angl	dam
N Range	one	N side	wndw	NN0.7	embrE		face	2	1	4v8	sde	clear
N Range	one	N side	wndw	NN0.8	embrW		face	2	1	2v12	up	dam
N Range	one	N side	wndw	NN0.9	embrW		face	5	1	2v12	up	clear
N Range	one	N side	corner	NStE	E side		face	1	1	4v8	up	clear
N Range	three	N side	wall	GNN	W side		face	1		6x10	up	clear
N Range	two	N side	frieze	bay1	metope 2		face	1	1	4w2	inv	worn
N Range	two	N side	frieze	bay1	centre		face	1	5	4w2	up	worn
N Range	two	N side	frieze	bay1	metope 11		face	1	1	7m5	inv	worn
N Range	two	N side	wall	bay6	E side	quoin	face	3	1	7m5	inv	worn
N Range	two	N side	wndw	NN1.2	embrE		face	3	1	4v8	sde	clear
N Range	two	N side	wall	NNW1.2	E side		face	1	2	7m5	up	clear
N Range	two	N side	wall	NNW1.2	E side		face	1	1	7m5	up	clear
E side												
N Range	one	E side	setback	NNE0.1	embrN		face	5	1	4w1	up	clear
S side												
N Range	one	S side	arcade	NNP1	pier		face	5	2	5v10	up	clear
N Range	one	S side	arcade	NNP3	spandrel		face	1	1	6av1	up	worn
N Range	one	S side	arch	NS0.1	arch	voussr	face	V8		3a46	up	worn
N Range	one	S side	arch	NS0.1	jmbE		face	2	1	3m10	up	clear
N Range	one	S side	arch	NS0.1	jmbW		face	4	1	4h1	inv	worn
N Range	one	S side	arch	NS0.1	jmbE		face	1	1	4t7	up	clear
N Range	one	S side	arch	NS0.1	jmbW		face	1	3	7ah1	up	clear
N Range	one	S side	arch	NS0.2	jmbW		face	3	1	2v1	up	worn
N Range	one	S side	arch	NS0.2	arch	voussr	face	V7		4w2	inv	worn
N Range	one	S side	arch	NS0.3	arch	voussr	face	V2E		4v8	up	clear
N Range	one	S side	arch	NS0.3	arch	keyst	face	V6		6xt1	up	worn
N Range	one	S side	arch	NS0.4	jmbE		face	4	1	4a3	up	worn
N Range	one	S side	arch	NS0.5	arch	voussr	face	V5		2t33	up	clear
N Range	one	S side	arch	NS0.5	arch	voussr	face	V6		2v2	up	clear
N Range	one	S side	arch	NS0.7	jmbE		face	3	1	2v1	inv	clear
N Range	one	S side	wndw	NSW0.2	jmbE		face	2	1	2b1	up	worn
N Range	one/two	S side	pilaster	PL1	flute		fillet3	5	1	7m5	inv	worn
N Range	one/two	S side	pilaster	PL2	flute		fillet4	7	1	5av1	up	worn
N Range	one/two	S side	pilaster	PL5	flute		fillet3	10	1	7m5	inv	worn
N Range	one/two	S side	pilaster	PL5	flute		fillet4	12	1	7m5	up	worn
N Range	one/two	S side	pilaster	PL6	flute		fillet4	5	1	5av1	up	worn



N Range	one/two	S side	pilaster	PL6	flute		fillet4	7	1	5av1	up	worn
<b>W Range</b>												
<b>W side</b>												
W Range	four	W side	chimney	WWCh2	stk base	S	face	2	2	6a31	up	worn
W Range	one	W side	fplace	Wfp0.3	lintel		face	1	1	8vj1	up	worn
W Range	one	W side	wndw	WW0.3	lintel	uppr	mould	1	2	4w2	up	clear
W Range	one	W side	wndw	WW0.3	jmbS	lwr	mould	2	1	4w2	inv	clear
W Range	one	W side	wndw	WW0.4	mull2	lwr	mould	1	1	3h1	up	worn
W Range	one	W side	wndw	WW0.4	jmbN	lwr	mould	3	1	3z50	up	worn
W Range	one	W side	wndw	WW0.4	jmbN	lwr	mould	1	1	4v20	up	worn
W Range	one	W side	wndw	WW0.4	mull2	lwr	mould	2	1	4z15	up	worn
W Range	one	W side	wndw	WW0.5	jmbN	lwr	mould	2	1	4v8	up	worn
W Range	one	W side	wndw	WW0.5	blcking	lwr	face	1	1	6a31	rev	clear
W Range	one	W side	wndw	WW0.6	embrS	quoin	face	2	1	11h2	up	worn
W Range	one	W side	wndw	WW0.6	jmbN		mould	1	1	12mt1	inv	worn
W Range	one	W side	wndw	WW0.6	embrN	quoin	face	4	1	3h1	up	worn
W Range	one	W side	wndw	WW0.7	mull1	uppr	mould	1	1	4h1	angl	clear
W Range	one	W side	wndw	WW0.7	jmbN	lwr	mould	1	1	4v8	up	clear
W Range	one	W side	wndw	WW0.7	mull2	lwr	mould	2	1	4w3	up	clear
W Range	one	W side	wndw	WW0.7	jmbS	lwr	mould	2	1	5a1	up	worn
W Range	one	W side	chimney	WWCh2		quoin	face	1	1	3h1	sde	worn
W Range	one	W side	chimney	WWCh3	plinth	quoin	face	1	1	3a2	sde	worn
W Range	one	W side	chimney	WWCh3	plinth	quoin	face	2	1	3h1	sde	clear
W Range	one	W side	chimney	WWCh3		quoin	face	5	1	3h1	up	clear
W Range	one	W side	chimney	WWCh3	plinth	quoin N	face	11	1	3h1	up	clear
W Range	one	W side	chimney	WWCh3	plinth	quoin N	face	14	1	3h1	sde	worn
W Range	two	W side	frieze	bay2	brdr	lwr	face	1	4	5m2	up	worn
W Range	two	W side	wndw	WW1.3	jmbS	uppr	mould	4	1	5a6	up	worn
W Range	two	W side	wndw	WW1.6	jmbN	uppr	mould	1	1	4v8	up	clear
W Range	two	W side	wndw	WW1.6	jmbS	uppr	mould	2	1	4v8	up	clear
<b>E side</b>												
W Range	one	E side	frieze	bay1	S end	border	lwr			4v8	up	clear
W Range	one	E side	frieze	bay2	WE0.5	border	lwr	1	5	4v8	up	worn
W Range	one	E side	wall	bay3	S end		face	4	1	2v12	rev	clear
W Range	one	E side	wall	bay3	S end		face	2	2	3a6	sde	worn
W Range	one	E side	door	D2	jmbN		face	3	1	6q1	up	clear
W Range	one	E side	wndw	WE0.1	embrN	quoin	face	1	1	11h2	sde	dam
W Range	one	E side	wndw	WE0.1	jmbN	lwr	mould	1	1	5mt1	up	obsc
W Range	one	E side	wndw	WE0.1	mull2	lwr	mould	2	1	7m5	inv	dam
W Range	one	E side	wndw	WE0.2	embrN	quoin	face	3	1	11h2	sde	worn
W Range	one	E side	wndw	WE0.2	embrS	quoin	face	2	1	11h2	sde	clear
W Range	one	E side	wndw	WE0.2	embrS	quoin	face	3	1	11h2	sde	worn
W Range	one	E side	wndw	WE0.2	embrS	quoin	face	4	1	11h2	sde	dam
W Range	one	E side	wndw	WE0.2	embrN	quoin	face	2	1	2v12	up	clear
W Range	one	E side	wndw	WE0.2	embrN	quoin	face	1	1	3b10	sde	clear
W Range	one	E side	wndw	WE0.2	embrS	quoin	face	1	1	3h1	up	clear
W Range	one	E side	wndw	WE0.3	embrN	quoin	face	2	1	11h2	sde	worn
W Range	one	E side	wndw	WE0.3	embrS	quoin	face	2	1	11h2	up	worn
W Range	one	E side	wndw	WE0.3	embrS	quoin	face	3	1	11h2	sde	dam
W Range	one	E side	wndw	WE0.3	embrN	quoin	face	3	1	11h2	up	clear
W Range	one	E side	wndw	WE0.3	embrS	quoin	face	4	1	11h2	sde	worn
W Range	one	E side	wndw	WE0.3	embrN	quoin	face	4	1	11h2	up	worn
W Range	one	E side	wndw	WE0.3	embrN	quoin	face	8	1	11h2	up	worn
W Range	one	E side	wndw	WE0.3	jmbN	lwr	mould	2	1	4r1	up	obsc
W Range	one	E side	wndw	WE0.3	jmbN	lwr	mould	1	1	5v9	up	clear
W Range	one	E side	wndw	WE0.4	embrN	quoin	face	1	1	11h2	sde	worn
W Range	one	E side	wndw	WE0.4	embrN	quoin	face	2	1	11h2	up	worn
W Range	one	E side	wndw	WE0.4	embrS	quoin	face	2	1	11h2	up	clear
W Range	one	E side	wndw	WE0.4	embrN	quoin	face	3	1	11h2	up	worn
W Range	one	E side	wndw	WE0.4	embrN	quoin	face	4	1	11h2	up	clear
W Range	one	E side	wndw	WE0.4	embrS	quoin	face	8	1	11h2	up	clear
W Range	one	E side	wndw	WE0.4	jmbS	lwr	mould	1	1	12mt1	up	clear
W Range	one	E side	wndw	WE0.4	jmbN	lwr	mould	2	1	6mt1	up	dam
W Range	one	E side	wndw	WE0.4	jmbS	lwr	mould	3	1	8mt1	up	clear
W Range	one	E side	wndw	WE0.4	jmbN	uppr	mould	4	1	8mt1	up	clear
W Range	one	E side	wndw	WE0.5	embrS	quoin	face	2	1	11h2	sde	worn
W Range	one	E side	wndw	WE0.5	embrN	quoin	face	2	1	11h2	sde	worn
W Range	one	E side	wndw	WE0.5	embrN	quoin	face	6	1	11h2	sde	worn
W Range	one	E side	wndw	WE0.5	jmbN	lwr	mould	1	1	3a50	inv	obsc
W Range	one	E side	wndw	WE0.5	jmbS	lwr	mould	2	1	4v8	up	worn
W Range	one	E side	wndw	WE0.5	jmbN	lwr	mould	2	1	6a3	up	clear
W Range	one	E side	wndw	WE0.5	mull2	lwr	mould	1	1	7m5	inv	worn

W Range	one	E side	wndw	WE0.6	embrN	quoin	face	1	1	11h2	sde	clear
W Range	one	E side	wndw	WE0.6	embrN	quoin	face	3	1	11h2	up	clear
W Range	one	E side	wndw	WE0.6	embrN	quoin	face	5	1	11h2	sde	clear
W Range	one	E side	wndw	WE0.6	embrN	quoin	face	6	1	3h1	up	clear
W Range	one	E side	wndw	WE0.6	jmbN	uppr	mould	2	1	4w2	inv	clear
W Range	one	E side	wndw	WE0.6	jmbN	lwr	mould	2	1	4w3	rev	dam
W Range	one/two	E side	pilaster	PL1	flute		fillet3	3	1	4b24	up	worn
W Range	one/two	E side	pilaster	PL1	flute		fillet3	4	1	4v8	up	worn
W Range	one/two	E side	pilaster	PL2	flute		fillet4	2	1	7m5	inv	worn
W Range	one/two	E side	pilaster	PL3	flute		fillet4	6	1	4pd1	up	worn
W Range	one/two	E side	pilaster	PL3	flute		fillet3	14	1	4pd1	up	worn
W Range	one/two	E side	pilaster	PL3	flute		fillet3	3	1	7m5	inv	worn
W Range	one/two	E side	pilaster	PL3	flute		fillet3	4	1	7m5	up	worn
W Range	one/two	E side	pilaster	PL3	flute		fillet3	4	1	7m5	up	worn
W Range	two	E side	wall	bay1	S end		face	9	5	10t1	up	worn
W Range	two	E side	wall	bay2	S end		face	4	6	4gv1	up	worn
W Range	two	E side	door	WED1.0	jmbE		face	5	1	4b1	sde	clear
<b>SW Range</b>												
<b>Pallt Ch</b>												
SW Range	one	Pallt Ch	frieze	bay1		SWW0.9	lwr		1	4b20	sde	clear
SW Range	one	Pallt Ch	wall	Q1E			face	1	1	4m1	sde	clear
SW Range	one	Pallt Ch	wall	Q1E			face	8	1	4w2	inv	dam
SW Range	one	Pallt Ch	wall	Q4E			face	5	1	3y1	up	dam
SW Range	one	Pallt Ch	wall	Q4E			face	11	1	4v8	up	dam
SW Range	one	Pallt Ch	wall	Q4E			face	6	1	4w2	inv	dam
SW Range	one	Pallt Ch	wndw	SWW0.9	mull1	lwr	mould	1	1	6a30	sde	clear
SW Range	one	Pallt Ch	wndw	SWW0.9	mull1	uppr	mould	3	1	6a30	sde	worn
<b>S side</b>												
SW Range	one	S side	wall	bay1	SW corner		face	2	3	4q7	angl	clear
SW Range	one	S side	wall	bay1	SW corner		face	3	3	4q7	angl	clear
SW Range	one	S side	wall	bay2	S wall		face	3	2	4q7	angl	clear
SW Range	one	S side	wall	bay2	S wall		face	4	3	4q7	sde	clear
SW Range	one	S side	wall	bay2	S wall		face	5	3	4q7	sde	worn
SW Range	one	S side	wall	bay2	S wall		face	8	3	4q7	angl	clear
SW Range	one	S side	wall	bay2	S wall		face	8	2	4q7	up	worn
SW Range	one	S side	wall	bay3	SE corner		face	1	1	2x1	sde	clear
SW Range	zero	S side	wall		S wall		face	5	2	4q7	sde	clear
SW Range	zero	S side	wall		SE wall		face	6	1	4q7	sde	clear
<b>E side</b>												
SW Range	one	E side	wall	bay2	NE corner		face	1	6	4q7	sde	clear
SW Range	one	E side	wall	bay2	NE corner		face	5	5	4q7	up	worn
SW Range	one	E side	wall	bay2			face	2	3	4w2	inv	worn
SW Range	one	E side	wall	bay2	NE corner		face	6	4	4w2	inv	worn
SW Range	zero	E side	wall	bay2	quoin		face	3	1	4q7	up	worn
<b>Lessr Str</b>												
SW Range	one	Lessr Str	door	DE2	jmbS		face	4	1	13h1	up	worn
SW Range	one	Lessr Str	door	DE2	jmbN		face	3	1	2v1	up	clear
SW Range	one	Lessr Str	door	DS1	jmbE		face	3	1	4w2	sde	clear
SW Range	one	Lessr Str	frieze	N side	crnce	lwr	face	1	4	3a13	up	worn
SW Range	one	Lessr Str	frieze	N side	brdr	lwr	face	1	5	4r1	sde inv	clear
SW Range	one	Lessr Str	quoin	SW	N side		face	2	1	4w2	up	clear
SW Range	one/two	Lessr Str	rail	F1N		uppr	rear	1	1	6v82	sde	clear
SW Range	one/two	Lessr Str	rail	F4S		uppr	rear	1	1	11h1	up	worn
SW Range	one/two	Lessr Str	rail	F6S		lwr	rear	2	1	4w2	up	clear
SW Range	three	Lessr Str	bay1W	cornice		uppr	face	3	1	4b10	up	worn
SW Range	two	Lessr Str	bay1W	cornice		lwr	face	1	4	2b1	up	worn
SW Range	two	Lessr Str	bay1W	cornice		lwr	face	1	5	4w2	up	worn
SW Range	two	Lessr Str	wndw	SWW2.10	jmbW	lwr	mould	1	1	3h30	up	clear
SW Range	zero	Lessr Str	door	DW1	jmbN		mould	4	1	4q7	up	clear
SW Range	zero	Lessr Str	door	DW1	jmbN		mould	2	1	6x10	sde	clear
<b>Passage</b>												
SW Range	one	Passage	door	D1	embrN		face	3	2	10rp1	up	clear
SW Range	one	Passage	wall	N of door	W wall		face	2	5	4q7	up	clear
SW Range	one	Passage	wall	N of door	W wall		face	3	2	4q7	up	worn
SW Range	one	Passage	wall	S end	W wall		face	10	2	3m10	rev	clear

SW Range	one	Passage	wall	S end	W wall		face	11	2	4w2	inv	clear
SW Range	one	Passage	wndw	SWE0.2	embrE		face			4m1	inv	clear
SW Range	two	Passage	wndw	SWE1.5	jmbE	uppr	mould			4v8	up	clear
SW Range	two	Passage	wndw	SWE1.6	jmbN	uppr	mould			4b10	up	worn
SW Range	two	Passage	wndw	SWE1.6	embrN	lwr	face	1	1	4w2	up	clear
<b>Lobby</b>												
SW Range	one	Lobby	door	DN1	jmbW	uppr	obelisk	1	1	3a6	up	clear
SW Range	one	Lobby	door	DN1	archt	lwr	mould	1	1	4b20	up	clear
SW Range	one	Lobby	door	DN2	jmbE		face	3	1	10x1	up	clear
SW Range	one	Lobby	door	DN2	jmbW		face	3	1	11h1	up	worn
SW Range	one	Lobby	door	DN2	crnce	uppr	mould	1	1	4b20	sde rev	clear
SW Range	one	Lobby	door	DN2	archt	lwr	mould	1	2	4b20	up	clear
SW Range	one	Lobby	door	DN2	crnce	uppr	mould	1	3	4q7	up	worn
SW Range	one	Lobby	wndw	SWW0.5	jmbN	lwr	mould	1	1	4w3	sde	worn
<b>Bllds Rm</b>												
SW Range	one	Bllds Rm	wndw	SWW0.15	mull4	mid	mould	1	1	4v8	up	clear
SW Range	zero	Bllds Rm	door	DS1	jmbE		mould	4	1	11h1	up	clear
SW Range	zero	Bllds Rm	door	DS1	jmbW		mould		1	4w2	sde	clear
<b>Libry</b>												
SW Range	one	Libry	wndw	SWW0.14	mull2	uppr	mould	2	1	10x1	up	dam
SW Range	one	Libry	wndw	SWW0.14	jmbE	uppr	mould	2	1	4r1	up	clear
SW Range	zero	Libry	wndw	SWW-0.14	3.1	infill	face	2	1	4q7	angl	worn
SW Range	zero	Libry	wndw	SWW-0.14	3.2	infill	face	2	1	4q7	sde	clear
SW Range	zero	Libry	wndw	SWW-0.14	2.1	infill	face	3	1	4q7	sde	clear
SW Range	zero	Libry	wndw	SWW-0.14	3.2	infill	face	3	1	4w2	inv	clear
SW Range	zero	Libry	wndw	SWW-0.14	2.2	infill	face	4	1	4w2	up	worn
<b>Gt Parlor</b>												
SW Range	one	Gt Parlor	wndw	SWW0.6	mull1	lwr	mould	1	1	4r1	up	dam
<b>Gt Stair</b>												
SW Range	one/two	Gt Stair	rail	F1N		uppr	rear	2	1	9x10	up	worn
SW Range	one/two	Gt Stair	rail	F1N		uppr	rear	5	1	9x10	sde	clear
SW Range	one/two	Gt Stair	rail	F2E		uppr	rear	2	1	3b10	up	clear
SW Range	one/two	Gt Stair	rail	F2E		lwr	rear	3	1	6a30	up	clear
SW Range	one/two	Gt Stair	rail	F2W		lwr	rear	3	1	11h1	sde	clear
SW Range	one/two	Gt Stair	rail	F2W		uppr	rear	2	1	5b4	up	clear
SW Range	one/two	Gt Stair	rail	F2W		uppr	rear	3	1	5b4	up	worn
SW Range	one/two	Gt Stair	rail	L1S		uppr	rear	3	1	5b4	up	clear
SW Range	one/two	Gt Stair	rail	L1W		lwr	rear	1	1	5b4	up	clear
SW Range	one/two	Gt Stair	rail	L2N		lwr	rear	2	1	3z50	up	clear
SW Range	one/two	Gt Stair	rail	L2N		lwr	rear	3	1	3z50	up	clear
<b>SW Range</b>	one/two	Gt Stair	rail	L2N		uppr	rear	2	1	4q7	sde	clear
SW Range	one/two	Gt Stair	rail	L2N		uppr	rear	3	1	4q7	up	clear
<b>Attic</b>												
SW Range	three	Attic	centre wall	S face	wall	lwr	face	3	1	4q7	angl	worn
SW Range	three	Attic	chimney	SWCh1	wall E		face	7	1	3b10	up	clear
SW Range	three	Attic	chimney	SWCh1	wall E		face	4	1	4b1	sde	clear
SW Range	three	Attic	chimney	SWCh1	wall E		face	3	1	4m1	sde	clear
SW Range	three	Attic	chimney	SWCh1	wall E		face	6	1	4z15	rev	clear
SW Range	three	Attic	wndw	SWW2.11	mull2	uppr	mould	1	1	4b1	up	clear
SW Range	three	Attic	centre wall	W face	wall	lwr	face	2	1	4q7	angl	clear
SW Range	three	Attic	centre wall	W face	wall	lwr	face	2	3	4w2	sde	clear
<b>BBed Ch</b>												
SW Range	two	BBed Ch	wndw	SWW1.14	mull2	uppr	mould	1	1	2x1	up	worn
SW Range	two	BBed Ch	wndw	SWW1.14	mull3	lwr	mould	1	1	4b20	sde rev	dam
<b>Wthdrg Ch</b>												
SW Range	two	Wthdrg Ch	wndw	SWW1.15	jmbSE	lwr	mould	1	1	3a4	up	worn
<b>Gt Ch</b>												
SW Range	two	Gt Ch	wndw	SWW1.5	jmbN	uppr	mould	2	1	2v12	up	clear
SW Range	two	Gt Ch	wndw	SWW1.5	jmbN	lwr	mould	1	1	5b4	up	clear



Cellar													
SW Range	zero	Cellar	chimney	capstone	loose	88107624	bed			4w2	up	clear	
S Range													
N side													
S Range	one	N side	wall	bay1	NE corner		lwr	face	2	1	4p12	inv	worn
S Range	one	N side	wall	bay5	E side			face	7	1	3z50	rev	worn
S Range	one	N side	wall	SN0.8	plinth			face	1	4	3t15	sde	worn
S Range	one/two	N side	pilaster	PL4	flute			W side	12	1	10ap1	up	clear
S Range	one/two	N side	pilaster	PL4	flute			fillet3	1	1	3a6	up	worn
S Range	one/two	N side	wndw	SN0.1	jmbE		lvl 1	mould	1	1	18h1	sde	worn
S Range	one/two	N side	wndw	SN0.1	mull1		lvl 1	mould	1	1	18h1	sde	worn
S Range	one/two	N side	wndw	SN0.1	jmbE		lvl 1	mould	2	1	18h1	sde	clear
S Range	one/two	N side	wndw	SN0.1	embrE		lvl 1	face	1	1	5x11	angl	clear
S Range	one/two	N side	wndw	SN0.1	embrE		lvl 1	face	2	1	5x11	up	clear
S Range	one/two	N side	wndw	SN0.2	jmbS		lvl 1	mould	2	1	18h1	sde	clear
S Range	one/two	N side	wndw	SN0.2	jmbS		lvl 2	mould	2	1	18h1	sde	clear
S Range	one/two	N side	wndw	SN0.2	embrS		lvl 1	face	2	1	4v8	angl	clear
S Range	one/two	N side	wndw	SN0.2	jmbS		lvl 1	mould	1	1	5x11	inv	clear
S Range	one/two	N side	wndw	SN0.2	mull3		lvl 2	mould	1	1	5x11	inv	clear
S Range	one/two	N side	wndw	SN0.2	mull2		lvl 2	mould	1	1	5x11	up	worn
S Range	one/two	N side	wndw	SN0.2	embrS		lvl 1	face	1	1	5x11	up	clear
S Range	one/two	N side	wndw	SN0.2	mull1		lvl 3	mould	1	1	5x11	up	worn
S Range	one/two	N side	wndw	SN0.2	mull2		lvl 3	mould	2	1	5x11	inv	clear
S Range	one/two	N side	wndw	SN0.2	embrS		lvl 1	face	4	1	5x11	inv	worn
S Range	one/two	N side	wndw	SN0.3	mull3		lvl 2	mould	1	1	3h1	up	worn
S Range	one/two	N side	wndw	SN0.3	mull2		lvl 5	mould	1	1	4pd1	up	clear
S Range	one/two	N side	wndw	SN0.3	mull2		lvl 4	mould	1	1	4v8	up	worn
S Range	one/two	N side	wndw	SN0.4	mull1		lvl 4	mould	1	1	4b22	up	clear
S Range	one/two	N side	wndw	SN0.4	mull1		lvl 1	mould	1	1	4bq1	up	clear
S Range	one/two	N side	wndw	SN0.4	embrW		lvl 1	face	1	1	4v8	sde	clear
S Range	one/two	N side	wndw	SN0.4	embrE		lvl 1	face	1	1	4v8	up	clear
S Range	one/two	N side	wndw	SN0.4	jmbE		lvl 2	mould	3	1	7m5	up	worn
S Range	one/two	N side	wndw	SN0.5	jmbW		lvl 1	mould	1	1	4v8	up	clear
S Range	one/two	N side	wndw	SN0.5	mull2		lvl 1	mould	1	1	4v8	up	clear
S Range	one/two	N side	wndw	SN0.5	jmbE		lvl 1	mould	1	1	7vh1	up	clear
S Range	one/two	N side	wndw	SN0.8	mull2		lvl 2	mould	3	1	2b1	angl	worn
S Range	one/two	N side	wndw	SN0.8	jmbE		lvl 1	mould	2	1	4w3	up	worn
Buttery													
S Range	one	Buttery	Blkd feature	BTW0.1			infill	face	1	4	4f1	up	worn
S Range	one	Buttery	Blkd feature	BTW0.1			infill	face	4	4	6a30	up	clear
S Range	two	Buttery	Blkd feature	BTW1.1	jmbS			face	7	1	2v1	sde	worn
S Range	two	Buttery	Blkd feature	BTW1.1	jmbS			face	4	1	4v8	up	worn
Porch													
S Range	one	Porch	wall	PEEx	E Wall			face	8	4	10x13	angl	worn
S Range	one	Porch	wall	PEEx	E Wall			face	5	3	3h3	up	worn
S Range	one	Porch	wall	PEEx	E Wall			face	2	3	3x17	rev	worn
S Range	one	Porch	wall	PEEx	E Wall			face	9	1	3x17	angl	worn
S Range	one	Porch	wall	PEEx	E Wall			face	9	2	3x17	angl	worn
S Range	one	Porch	wall	PEEx	E Wall			face	9	4	3x17	angl	clear

S Range	one	Porch	wall	PEEx	E Wall	face	8	3	5p13	angl	worn
S Range	one	Porch	wall	PEEx	E Wall	face	5	1	7p24	up	clear
S Range	one	Porch	wall	PEEx	E Wall	face	5	2	8x3	angl	worn
S Range	one	Porch	wall	PEEx	E Wall	face	8	5	9x12	up	clear
S Range	one	Porch	wall	PEEx	E Wall	face	7	5	9x12	sde	worn
S Range	one	Porch	wall	PEI	E Wall	face	4	1	3a1	angl	clear
S Range	one	Porch	wall	PEI	E Wall	face	5	4	3gv1	up	worn
S Range	one	Porch	wall	PEI	E Wall	face	10	3	3gv1	inv	worn
S Range	one	Porch	wall	PEI	E Wall	face	10	4	3h3	rev	clear
S Range	one	Porch	wall	PEI	E Wall	face	3	4	3t15	up	worn
S Range	one	Porch	wall	PEI	E Wall	face	5	6	3t16	up	worn
S Range	one	Porch	wall	PEI	E Wall	face	9	2	4g9	up	worn
S Range	one	Porch	wall	PEI	E Wall	face	3	2	5p13	sde	worn
S Range	one	Porch	wall	PEI	E Wall	face	11	5	7gv14	up	worn
S Range	one	Porch	wall	PEI	E Wall	face	9	5	7gv14	up	worn
S Range	one	Porch	wall	PEI	E Wall	face	11	4	7gv14	up	worn
S Range	one	Porch	wall	PEI	E Wall	face	5	3	7gv4	up	worn
S Range	one	Porch	wall	PEI	E Wall	face	2	2	7xy1	up	worn
S Range	one	Porch	wall	PEI	E Wall	face	4	4	8x3	sde	worn
S Range	one	Porch	wall	PEI	E Wall	face	3	3	9gv6	up	worn
S Range	one	Porch	wall	PEI	E Wall	face	4	2	9gv6	up	clear
S Range	one	Porch	wall	PEI	E Wall	face	8	5	9x12	inv	clear
S Range	one	Porch	wall	PEI	E Wall	face	8	1	9x12	up	worn
S Range	one	Porch	wall	PEI	E Wall	face	6	3	9x12	sde	worn
S Range	one	Porch	wall	PEI	E Wall	face	6	4	9x12	up	clear
S Range	one	Porch	wall	PEI	E Wall	face	11	3	9x12	up	clear
S Range	one	Porch	wall	PEI	E Wall	face	8	2	9x12	up	clear
S Range	one	Porch	wall	PEI	E Wall	face	9	3	9x12	up	worn
S Range	one	Porch	wall	PNI	N Wall	face	12	5	3x17	inv	clear
S Range	one	Porch	wall	PNI	N Wall	face	6	1	4p12	rev	clear
S Range	one	Porch	wall	PNI	N Wall	face	11	1	5gv2	up	clear
S Range	one	Porch	wall	PNI	N Wall	face	11	2	6gv20	up	clear
S Range	one	Porch	wall	PNI	N Wall	face	7	1	7x7	up	clear
S Range	one	Porch	wall	PNI	N Wall	face	4	1	9gv6	up	worn
S Range	one	Porch	wall	PNI	N Wall	face	14	1	9wp1	sde	clear
S Range	one	Porch	wall	PNI	N Wall	face	13	1	9wp2	up	clear
S Range	one	Porch	wall	PWEx	W Wall	face	3	4	11xp9	up	worn
S Range	one	Porch	wall	PWEx	W Wall	face	4	5	5gv2	up	worn
S Range	one	Porch	wall	PWEx	W Wall	face	7	4	5p13	up	worn
S Range	one	Porch	wall	PWEx	W Wall	face	6	4	7gv14	up	worn
S Range	one	Porch	wall	PWEx	W Wall	face	8	3	7x10	up	worn
S Range	one	Porch	wall	PWEx	W Wall	face	9	3	7x10	rev	worn
S Range	one	Porch	wall	PWEx	W Wall	face	5	4	9x12	sde	worn
S Range	one	Porch	wall	PWEx	W Wall	face	8	2	9x12	rev	worn
S Range	one	Porch	wall	PWEx	W Wall	face	6	5	9x12	up	worn
S Range	one	Porch	wall	PWEx	W Wall	face	5	3	9x12	up	worn
S Range	one	Porch	wall	PWEx	W Wall	face	8	1	9x12	up	worn
S Range	one	Porch	wall	PWI	W Wall	face	8	5	10x13	angl	clear
S Range	one	Porch	wall	PWI	W Wall	face	8	4	10x13	angl	clear
S Range	one	Porch	wall	PWI	W Wall	face	9	2	10x8	up	worn
S Range	one	Porch	wall	PWI	W Wall	face	9	1	10x8	angl	clear
S Range	one	Porch	wall	PWI	W Wall	face	11	3	11x14	angl	clear
S Range	one	Porch	wall	PWI	W Wall	face	2	4	1b3	up	clear
S Range	one	Porch	wall	PWI	W Wall	face	5	4	2x1	up	clear
S Range	one	Porch	wall	PWI	W Wall	face	2	5	3t17	sde	worn
S Range	one	Porch	wall	PWI	W Wall	face	2	3	3t17	up	worn
S Range	one	Porch	wall	PWI	W Wall	face	12	2	3x17	inv	clear
S Range	one	Porch	wall	PWI	W Wall	face	12	4	4g10	angl	worn
S Range	one	Porch	wall	PWI	W Wall	face	6	4	4p12	angl	worn
S Range	one	Porch	wall	PWI	W Wall	face	5	5	5gv2	up	worn
S Range	one	Porch	wall	PWI	W Wall	face	12	3	6gv11	angl	worn
S Range	one	Porch	wall	PWI	W Wall	face	10	2	6gv9	angl	worn
S Range	one	Porch	wall	PWI	W Wall	face	10	4	6gv9	inv	clear
S Range	one	Porch	wall	PWI	W Wall	face	10	3	6gv9	up	worn
S Range	one	Porch	wall	PWI	W Wall	face	3	3	7gv14	up	clear
S Range	one	Porch	wall	PWI	W Wall	face	7	5	7gv14	up	clear
S Range	one	Porch	wall	PWI	W Wall	face	11	2	7gv4	up	worn
S Range	one	Porch	wall	PWI	W Wall	face	8	2	7gv4	up	clear
S Range	one	Porch	wall	PWI	W Wall	face	8	3	8gv7	up	worn
S Range	one	Porch	wall	PWI	W Wall	face	9	3	8gv8	up	worn
S Range	one	Porch	wall	PWI	W Wall	face	9	4	8vg8	up	clear
S Range	one	Porch	wall	PWI	W Wall	face	10	1	8x11	sde	worn
S Range	one	Porch	wall	PWI	W Wall	face	12	5	8x3	angl	clear



S Range	one	Porch	wall	PWl	W Wall		face	7	2	9x12	up	clear
S Range	one	Porch	wall	PWl	W Wall		face	7	4	9x12	angl	clear
S Range	two	Porch	wall	PEEx	E Wall		face	1	1	11x14	up	worn
S Range	two	Porch	wall	PEEx	E Wall		face	2	4	4h1	sde	clear
S Range	two	Porch	wall	PEEx	E Wall		face	3	1	4h1	sde	clear
S Range	two	Porch	wall	PEEx	E Wall		face	3	4	4h1	sde	worn
S Range	two	Porch	wall	PEEx	E Wall		face	1	3	6p7	angl	worn
S Range	two	Porch	wall	PEEx	E Wall		face	1	2	7p5	angl	worn
S Range	two	Porch	wall	PWEx	W Wall		face	2	4	4h1	sde	worn
S Range	two	Porch	wall	PWEx	W Wall		face	2	2	4h1	sde	worn
S Range	two	Porch	wall	PWEx	W Wall		face	2	3	4h1	sde	worn
S Range	two	Porch	wall	PWEx	W Wall		face	4	6	4h1	sde	worn
S Range	two	Porch	wall	PWEx	W Wall		face	5	3	4h1	sde	worn
S Range	two	Porch	wall	PWEx	W Wall		face	8	2	4h1	sde	worn
<b>S side</b>												
S Range	one/two	S side	chimney	SSCh1	W side	quin	face	15	1	2x1	up	dam
S Range	one/two	S side	chimney	SSCh1	W side	quin	face	5	1	4q7	sde	worn
S Range	one/two	S side	chimney	SSCh1	W side	quin	face	4	1	6v82	up	worn
<b>E Range</b>												
<b>W side</b>												
E Range	one	W side	wall	bay1	plinth		face	1	5	4a1	up	worn
E Range	one	W side	wall	bay2	plinth		face	1	2	4a1	up	worn
E Range	one	W side	wall	bay2			face	7	1	4a1	up	worn
E Range	one	W side	wall	bay2			face	6	1	6p7	rev	worn
E Range	one	W side	wall	bay3			face	3	2	3a6	up	worn
E Range	one	W side	wall	bay3			face	10	2	7p5	up	worn
E Range	one	W side	wall	bay4			face	10	2	7ah1	up	clear
E Range	one	W side	wall	bay4			face	10	3	7x10	up	clear
E Range	one	W side	wall	bay5			face	10	4	7ah1	up	clear
E Range	one	W side	wall	bay5			face	10	2	4a1	up	clear
E Range	one	W side	wall	bay5			face	9	2	4a1	inv	clear
E Range	one	W side	wall	bay5			face	9	4	4a1	up	clear
E Range	one	W side	wall	bay6			face	7	4	7ah1	inv	worn
E Range	one	W side	wall	bay6			face	3	2	3h1	up	worn
E Range	one	W side	wall	bay6			face	3	1	5a11	up	worn
E Range	one	W side	wall	bay6			face	4	1	4a1	up	clear
E Range	one	W side	wall	bay6			face	5	2	4a1	up	clear
E Range	one	W side	wall	bay6			face	9	1	9x12	up	clear
E Range	one	W side	wall	bay6			face	4	2	5a11	up	worn
E Range	one	W side	wall	bay6			face	7	2	5a11	up	worn
E Range	one	W side	wall	bay6			face	8	1	9x12	up	clear
E Range	one	W side	wall	bay6			face	8	6	7ah1	up	clear
E Range	one	W side	wall	bay6			face	10	4	7ah1	inv	clear
E Range	one	W side	wndw	EW0.1	mull3	lwr	mould	1	1	2x1	up	clear
E Range	one	W side	wndw	EW0.1	jmbS	uppr	mould	2	1	3l1	up	clear
E Range	one	W side	wndw	EW0.1	jmbN	lwr	mould	2	1	4h1	up	clear
E Range	one	W side	wndw	EW0.1	sill	int	mould	1	1	4q2	up	clear
E Range	one	W side	wndw	EW0.2	mull3	lwr	mould	1	1	2t5	up	clear
E Range	one	W side	wndw	EW0.2	embrN	uppr	face	5	1	3a2	up	dam
E Range	one	W side	wndw	EW0.2	jmbN	lwr	mould	2	1	3l1	up	clear
E Range	one	W side	wndw	EW0.3	jmbN	uppr	mould	1	1	3l1	up	clear
E Range	one	W side	wndw	EW0.3	mull3	lwr	mould	1	1	3z51	up	clear
E Range	one	W side	wndw	EW0.3	mull1	uppr	mould	1	1	5f55	up	clear
E Range	one	W side	wndw	EW0.4	jmbS	uppr	mould	1	1	5eh1	up	worn
E Range	one	W side	wndw	EW0.4	jmbS	lwr	mould	2	1	7l2	up	worn
E Range	one	W side	wndw	EW0.5	mull2	lwr	mould	2	1	4a2	up	clear
E Range	one	W side	wndw	EW0.6	mull2	lwr	mould	1	1	3l1	rev	clear
E Range	one	W side	wall	bay3			face	10	3	2x1	up	worn
E Range	one/two	W side	pilaster	PL1	flute		fillet3	3	1	6a42	up	worn
E Range	one/two	W side	pilaster	PL1	flute		fillet3	2	1	7m5	up	worn
E Range	one/two	W side	pilaster	PL1	flute		fillet3	7	1	7m5	up	worn
E Range	one/two	W side	pilaster	PL1	flute		fillet5	14	1	7m5	up	worn
E Range	one/two	W side	pilaster	PL2	flute		fillet4	5	1	3a6	rev	worn
E Range	one/two	W side	pilaster	PL2	flute		fillet4	4	1	5av1	rev	worn
E Range	one/two	W side	pilaster	PL2	flute		fillet4	2	1	7m5	up	worn

E Range	one/two	W side	pilaster	PL2	flute		fillet4	2	1	7m5	up	worn
E Range	one/two	W side	pilaster	PL2	flute		fillet4	4	1	7m5	rev	worn
E Range	one/two	W side	pilaster	PL3	flute		fillet3	5	1	3q2	up	worn
E Range	one/two	W side	pilaster	PL3	flute		fillet3	2	1	5av1	up	worn
E Range	one/two	W side	pilaster	PL3	flute		fillet3	2	1	5av1	up	worn
E Range	one/two	W side	pilaster	PL3	flute		fillet3	6	1	5av1	up	worn
E Range	one/two	W side	pilaster	PL3	flute		fillet4	4	1	7m5	up	worn
E Range	two	W side	wndw	EW1.2	jmbN	uppr	mould	2	1	4v8	sde	dam
E Range	two	W side	wndw	EW1.3	embrN	lwr	face	1	1	2d1	up	clear
<b>E side</b>												
E Range	two	E side	wndw	EE1.7	sill		under	1	1	2x1	up	worn
E Range	two	E side	wndw	EEE1.1	jmbS	uppr	mould	1	1	5f55	up	worn
E Range	two	E side	wndw	EEE1.1	lintel	under	mould	1	1	6a30	sde	clear
E Range	two	E side	wndw	EEE1.1	transom	under	mould	1	1	6a30	sde	clear
E Range	two	E side	wndw	EEE1.2	jmbN		mould	3	1	4w2	sde	clear
E Range	two	E side	wall	EEES	quin W		face	10	1	4q7	up	clear
E Range	two	E side	wall	EEES	quin E		face	6	1	4q7	up	worn
E Range	two	E side	corbel	EES1	SE corner		face	1	1	4q7	sde	clear
E Range	two	E side	wall	EESE1	quin SE		face	15	1	10h1	sde	worn
E Range	two	E side	wall	EESE1	quin SE		face	16	1	2x1	up	worn
E Range	two	E side	wall	EESE1	quin SE		face	11	1	3h1	sde	worn
E Range	two	E side	wall	EESE1	quin S		face	14	1	3h1	sde	worn
E Range	two	E side	wall	EESE1	quin SE		face	17	1	6a30	up	worn
E Range	two	E side	wall	EESE1	quin S		face	18	1	6a30	up	worn
<b>W Gate</b>												
<b>W side</b>												
W Gate	one	W side	arch	main	uppr	voussr	face	V5		2x1	up	clear
W Gate	one	W side	arch	niche N	back wall		face	6	1	8v1	up	worn
W Gate	one	W side	arch	niche S	embrS		face	3	2	13h1	up	worn
W Gate	one	W side	arch	niche S	back wall		face	7	1	4q7	up	clear
<b>E side</b>												
W Gate	one	E side	arch	niche N	back wall		face	6	2	6w10	inv	worn
W Gate	one	E side	arch	niche S	back wall		face	5	2	15h1	up	worn
W Gate	one	E side	arch	niche S	back wall		face	2	1	3s1	up	worn
W Gate	one	E side	arch	niche S	back wall		face	1	2	5p13	rev	worn
<b>E Gate</b>												
<b>E side</b>												
E Gate	one	E side	arch	niche N	back wall		face	4	1	2x1	up	clear
E Gate	one	E side	arch	niche N	arch	spandrel N	face	1	1	3v10	up	worn
E Gate	one	E side	arch	niche N	back wall		face	5	2	4p12	sde	worn
E Gate	one	E side	arch	niche N	arch	voussr	face	V2		4p7	up	worn
E Gate	one	E side	arch	niche N	arch	voussr	face	V4		4r4	up	worn
E Gate	one	E side	arch	niche N	arch	spandrel S	face	1	1	6w10	sde	worn
E Gate	one	E side	arch	niche N	embrS		face	3	2	7m5	sde	worn
E Gate	one	E side	arch	niche N	back wall		face	7	1	8m6	up	clear
E Gate	one	E side	arch	niche S	impost N		face	1	1	5t6	up	clear
E Gate	one	E side	arch	niche S	impost S		face	1	1	5t6	up	clear
<b>W side</b>												
E Gate	one	W side	arch	niche N	arch	soffit	face	1	2	4r4	up	clear
E Gate	one	W side	arch	niche S	arch	soffit	face	1	2	4m5	up	worn
E Gate	one	W side	arch	niche S	back wall		face	6	2	6a31	rev	clear
E Gate	one	W side	arch	pier	rebate		face	3	1	4m23	up	worn
<b>N side</b>												
E Gate	one	N side	arch	wall	uppr	centre	face	1	1	3h15	up	worn
E Gate	one	N side	arch	wall	uppr	centre	face	6	1	3h15	up	worn
E Gate	one	N side	arch	wall	uppr	centre	face	4	1	4m10	up	clear
E Gate	one	N side	arch	wall	uppr	centre	face	5	1	6x11	up	clear

KH Zone	Level	Zone 2	Feature 1	Feature2	Feature 3	Feature 4	Surface	Crse	Stone	Mark	Orient.	Cond.
10ap1												
S Range	one/two	N side	pilaster	PL4	flute		W side	12	1	10ap1	up	clear
10h1												
E Range	two	E side	wall	EESE1	quoin SE		face	15	1	10h1	sde	worn
10rp1												
SW Range	one	Passage	door	D1	embrN		face	3	2	10rp1	up	clear
10tt1												
W Range	two	E side	wall	bay1	S end		face	9	5	10tt1	up	worn
10x1												
SW Range	one	Libry	wndw	SWW0.14	mull2	uppr	mould	2	1	10x1	up	dam
SW Range	one	Lobby	door	DN2	jmbE		face	3	1	10x1	up	clear
10x13												
S Range	one	Porch	wall	PEEx	E Wall		face	8	4	10x13	angl	worn
S Range	one	Porch	wall	PWI	W Wall		face	8	5	10x13	angl	clear
S Range	one	Porch	wall	PWI	W Wall		face	8	4	10x13	angl	clear
10x8												
S Range	one	Porch	wall	PWI	W Wall		face	9	2	10x8	up	worn
S Range	one	Porch	wall	PWI	W Wall		face	9	1	10x8	angl	clear
11h1												
SW Range	zero	Bllds Rm	door	DS1	jmbE		mould	4	1	11h1	up	clear
SW Range	one/two	Gt Stair	rail	F2W		lwr	rear	3	1	11h1	sde	clear
SW Range	one/two	Lessr Str	rail	F4S		uppr	rear	1	1	11h1	up	worn
SW Range	one	Lobby	door	DN2	jmbW		face	3	1	11h1	up	worn
11h2												
W Range	one	E side	wndw	WE0.1	embrN	quoin	face	1	1	11h2	sde	dam
W Range	one	E side	wndw	WE0.2	embrN	quoin	face	3	1	11h2	sde	worn
W Range	one	E side	wndw	WE0.2	embrS	quoin	face	2	1	11h2	sde	clear
W Range	one	E side	wndw	WE0.2	embrS	quoin	face	3	1	11h2	sde	worn
W Range	one	E side	wndw	WE0.2	embrS	quoin	face	4	1	11h2	sde	dam
W Range	one	E side	wndw	WE0.3	embrN	quoin	face	2	1	11h2	sde	worn
W Range	one	E side	wndw	WE0.3	embrS	quoin	face	2	1	11h2	up	worn
W Range	one	E side	wndw	WE0.3	embrS	quoin	face	3	1	11h2	sde	dam
W Range	one	E side	wndw	WE0.3	embrN	quoin	face	3	1	11h2	up	clear
W Range	one	E side	wndw	WE0.3	embrS	quoin	face	4	1	11h2	sde	worn
W Range	one	E side	wndw	WE0.3	embrN	quoin	face	4	1	11h2	up	worn
W Range	one	E side	wndw	WE0.3	embrN	quoin	face	8	1	11h2	up	worn
W Range	one	E side	wndw	WE0.4	embrN	quoin	face	1	1	11h2	sde	worn
W Range	one	E side	wndw	WE0.4	embrN	quoin	face	2	1	11h2	up	worn
W Range	one	E side	wndw	WE0.4	embrS	quoin	face	2	1	11h2	up	clear
W Range	one	E side	wndw	WE0.4	embrN	quoin	face	3	1	11h2	up	worn
W Range	one	E side	wndw	WE0.4	embrN	quoin	face	4	1	11h2	up	clear
W Range	one	E side	wndw	WE0.4	embrS	quoin	face	8	1	11h2	up	clear
W Range	one	E side	wndw	WE0.5	embrS	quoin	face	2	1	11h2	sde	worn
W Range	one	E side	wndw	WE0.5	embrN	quoin	face	2	1	11h2	sde	worn
W Range	one	E side	wndw	WE0.5	embrN	quoin	face	6	1	11h2	sde	worn
W Range	one	E side	wndw	WE0.6	embrN	quoin	face	1	1	11h2	sde	clear
W Range	one	E side	wndw	WE0.6	embrN	quoin	face	3	1	11h2	up	clear
W Range	one	E side	wndw	WE0.6	embrN	quoin	face	5	1	11h2	sde	clear
W Range	one	W side	wndw	WW0.6	embrS	quoin	face	2	1	11h2	up	worn
11x14												
S Range	one	Porch	wall	PWI	W Wall		face	11	3	11x14	angl	clear
S Range	two	Porch	wall	PEEx	E Wall		face	1	1	11x14	up	worn
11xp9												
S Range	one	Porch	wall	PWEx	W Wall		face	3	4	11xp9	up	worn
12mt1												
W Range	one	E side	wndw	WE0.4	jmbS	lwr	mould	1	1	12mt1	up	clear
W Range	one	W side	wndw	WW0.6	jmbN		mould	1	1	12mt1	inv	worn
13h1												
SW Range	one	Lessr Str	door	DE2	jmbS		face	4	1	13h1	up	worn
W Gate	one	W side	arch	niche S	embrS		face	3	2	13h1	up	worn
15h1												
W Gate	one	E side	arch	niche S	back wall		face	5	2	15h1	up	worn
18h1												
S Range	one/two	N side	wndw	SN0.1	jmbE	lvl 1	mould	1	1	18h1	sde	worn
S Range	one/two	N side	wndw	SN0.1	mull1	lvl 1	mould	1	1	18h1	sde	worn



S Range	one/two	N side	wndw	SN0.1	jmbE	lvl 1	mould	2	1	18h1	sde	clear
S Range	one/two	N side	wndw	SN0.2	jmbS	lvl 1	mould	2	1	18h1	sde	clear
S Range	one/two	N side	wndw	SN0.2	jmbS	lvl 2	mould	2	1	18h1	sde	clear
<b>1b3</b>												
S Range	one	Porch	wall	PWI	W Wall		face	2	4	1b3	up	clear
<b>2b1</b>												
N Range	one	N side	wndw	NN0.6	embrE		face	1	1	2b1	angl	dam
N Range	one	S side	wndw	NSW0.2	jmbE		face	2	1	2b1	up	worn
S Range	one/two	N side	wndw	SN0.8	mull2	lvl 2	mould	3	1	2b1	angl	worn
SW Range	two	Lessr Str	bay1W	cornice		lwr	face	1	4	2b1	up	worn
<b>2d1</b>												
E Range	two	W side	wndw	EW1.3	embrN	lwr	face	1	1	2d1	up	clear
<b>2t33</b>												
N Range	one	S side	arch	NS0.5	arch	voussr	face	V5		2t33	up	clear
<b>2t5</b>												
E Range	one	W side	wndw	EW0.2	mull3	lwr	mould	1	1	2t5	up	clear
<b>2v1</b>												
N Range	one	S side	arch	NS0.2	jmbW		face	3	1	2v1	up	worn
N Range	one	S side	arch	NS0.7	jmbE		face	3	1	2v1	inv	clear
S Range	two	Buttery	Blkd feature	BTW1.1	jmbS		face	7	1	2v1	sde	worn
SW Range	one	Lessr Str	door	DE2	jmbN		face	3	1	2v1	up	clear
<b>2v12</b>												
N Range	one	N side	wndw	NN0.8	embrW		face	2	1	2v12	up	dam
N Range	one	N side	wndw	NN0.9	embrW		face	5	1	2v12	up	clear
SW Range	two	Gt Ch	wndw	SWW1.5	jmbN	uppr	mould	2	1	2v12	up	clear
W Range	one	E side	wall	bay3	S end		face	4	1	2v12	rev	clear
W Range	one	E side	wndw	WE0.2	embrN	quoin	face	2	1	2v12	up	clear
<b>2v2</b>												
N Range	one	S side	arch	NS0.5	arch	voussr	face	V6		2v2	up	clear
<b>2x1</b>												
E Gate	one	E side	arch	niche N	back wall		face	4	1	2x1	up	clear
E Range	two	E side	wndw	EE1.7	sill		under	1	1	2x1	up	worn
E Range	two	E side	wall	EESE1	quoin SE		face	16	1	2x1	up	worn
E Range	one	W side	wndw	EW0.1	mull3	lwr	mould	1	1	2x1	up	clear
E Range	one	W side	wall		bay3		face	10	3	2x1	up	worn
S Range	one	Porch	wall	PWI	W Wall		face	5	4	2x1	up	clear
S Range	one/two	S side	chimney	SSCh1	W side	quoin	face	15	1	2x1	up	dam
SW Range	two	BBed Ch	wndw	SWW1.14	mull2	uppr	mould	1	1	2x1	up	worn
SW Range	one	S side	wall	bay3	SE corner		face	1	1	2x1	sde	clear
W Gate	one	W side	arch	main	uppr	voussr	face	V5		2x1	up	clear
<b>3a1</b>												
S Range	one	Porch	wall	PEI	E Wall		face	4	1	3a1	angl	clear
<b>3a13</b>												
SW Range	one	Lessr Str	frieze	N side	crnce	lwr	face	1	4	3a13	up	worn
<b>3a2</b>												
E Range	one	W side	wndw	EW0.2	embrN	uppr	face	5	1	3a2	up	dam
W Range	one	W side	chimney	WWCh3	plinth	quoin	face	1	1	3a2	sde	worn
<b>3a4</b>												
SW Range	two	WthdrG Ch	wndw	SWW1.15	jmbSE	lwr	mould	1	1	3a4	up	worn
<b>3a46</b>												
N Range	one	S side	arch	NS0.1	arch	voussr	face	V8		3a46	up	worn
<b>3a50</b>												
W Range	one	E side	wndw	WE0.5	jmbN	lwr	mould	1	1	3a50	inv	obsc
<b>3a6</b>												
E Range	one	W side	wall	bay3			face	3	2	3a6	up	worn
E Range	one/two	W side	pilaster	PL2	flute		fillet4	5	1	3a6	rev	worn
S Range	one/two	N side	pilaster	PL4	flute		fillet3	1	1	3a6	up	worn
SW Range	one	Lobby	door	DN1	jmbW	uppr	obelisk	1	1	3a6	up	clear
W Range	one	E side	wall	bay3	S end		face	2	2	3a6	sde	worn
<b>3b10</b>												
SW Range	three	Attic	chimney	SWCh1	wall E		face	7	1	3b10	up	clear
SW Range	one/two	Gt Stair	rail	F2E		uppr	rear	2	1	3b10	up	clear
W Range	one	E side	wndw	WE0.2	embrN	quoin	face	1	1	3b10	sde	clear
<b>3gv1</b>												
S Range	one	Porch	wall	PEI	E Wall		face	5	4	3gv1	up	worn
S Range	one	Porch	wall	PEI	E Wall		face	10	3	3gv1	inv	worn
<b>3h1</b>												
E Range	two	E side	wall	EESE1	quoin SE		face	11	1	3h1	sde	worn

E Range	two	E side	wall	EESE1	quin S		face	14	1	3h1	sde	worn
E Range	one	W side	wall	bay6			face	3	2	3h1	up	worn
S Range	one/two	N side	wndw	SN0.3	mull3	lvl 2	mould	1	1	3h1	up	worn
W Range	one	E side	wndw	WE0.2	embrS	quin	face	1	1	3h1	up	clear
W Range	one	E side	wndw	WE0.6	embrN	quin	face	6	1	3h1	up	clear
W Range	one	W side	wndw	WW0.4	mull2	lwr	mould	1	1	3h1	up	worn
W Range	one	W side	wndw	WW0.6	embrN	quin	face	4	1	3h1	up	worn
W Range	one	W side	chimney	WWCh2		quin	face	1	1	3h1	sde	worn
W Range	one	W side	chimney	WWCh3	plinth	quin	face	2	1	3h1	sde	clear
W Range	one	W side	chimney	WWCh3		quin	face	5	1	3h1	up	clear
W Range	one	W side	chimney	WWCh3	plinth	quin N	face	11	1	3h1	up	clear
W Range	one	W side	chimney	WWCh3	plinth	quin N	face	14	1	3h1	sde	worn
<b>3h15</b>												
E Gate	one	N side	arch	wall	uppr	centre	face	1	1	3h15	up	worn
E Gate	one	N side	arch	wall	uppr	centre	face	6	1	3h15	up	worn
<b>3h3</b>												
S Range	one	Porch	wall	PEEx	E Wall		face	5	3	3h3	up	worn
S Range	one	Porch	wall	PEI	E Wall		face	10	4	3h3	rev	clear
<b>3h30</b>												
SW Range	two	Lessr Str	wndw	SWW2.10	jmbW	lwr	mould	1	1	3h30	up	clear
<b>3i1</b>												
E Range	one	W side	wndw	EW0.1	jmbS	uppr	mould	2	1	3i1	up	clear
E Range	one	W side	wndw	EW0.2	jmbN	lwr	mould	2	1	3i1	up	clear
E Range	one	W side	wndw	EW0.3	jmbN	uppr	mould	1	1	3i1	up	clear
E Range	one	W side	wndw	EW0.6	mull2	lwr	mould	1	1	3i1	rev	clear
<b>3m10</b>												
N Range	one	S side	arch	NS0.1	jmbE		face	2	1	3m10	up	clear
SW Range	one	Passage	wall	S end	W wall		face	10	2	3m10	rev	clear
<b>3q2</b>												
E Range	one/two	W side	pilaster	PL3	flute		fillet3	5	1	3q2	up	worn
<b>3s1</b>												
W Gate	one	E side	arch	niche S	back wall		face	2	1	3s1	up	worn
<b>3t15</b>												
S Range	one	N side	wall	SN0.8	plinth		face	1	4	3t15	sde	worn
S Range	one	Porch	wall	PEI	E Wall		face	3	4	3t15	up	worn
<b>3t16</b>												
S Range	one	Porch	wall	PEI	E Wall		face	5	6	3t16	up	worn
<b>3t17</b>												
S Range	one	Porch	wall	PWI	W Wall		face	2	5	3t17	sde	worn
S Range	one	Porch	wall	PWI	W Wall		face	2	3	3t17	up	worn
<b>3v10</b>												
E Gate	one	E side	arch	niche N	arch	spandrel N	face	1	1	3v10	up	worn
<b>3x17</b>												
S Range	one	Porch	wall	PEEx	E Wall		face	2	3	3x17	rev	worn
S Range	one	Porch	wall	PEEx	E Wall		face	9	1	3x17	angl	worn
S Range	one	Porch	wall	PEEx	E Wall		face	9	2	3x17	angl	worn
S Range	one	Porch	wall	PEEx	E Wall		face	9	4	3x17	angl	clear
S Range	one	Porch	wall	PNI	N Wall		face	12	5	3x17	inv	clear
S Range	one	Porch	wall	PWI	W Wall		face	12	2	3x17	inv	clear
<b>3y1</b>												
SW Range	one	Pallt Ch	wall	Q4E			face	5	1	3y1	up	dam
<b>3z50</b>												
S Range	one	N side	wall	bay5	E side		face	7	1	3z50	rev	worn
SW Range	one/two	Gt Stair	rail	L2N		lwr	rear	2	1	3z50	up	clear
SW Range	one/two	Gt Stair	rail	L2N		lwr	rear	3	1	3z50	up	clear
W Range	one	W side	wndw	WW0.4	jmbN	lwr	mould	3	1	3z50	up	worn
<b>3z51</b>												
E Range	one	W side	wndw	EW0.3	mull3	lwr	mould	1	1	3z51	up	clear
<b>4a1</b>												
E Range	one	W side	wall	bay1	plinth		face	1	5	4a1	up	worn
E Range	one	W side	wall	bay2	plinth		face	1	2	4a1	up	worn
E Range	one	W side	wall	bay2			face	7	1	4a1	up	worn
E Range	one	W side	wall	bay5			face	10	2	4a1	up	clear
E Range	one	W side	wall	bay5			face	9	2	4a1	inv	clear
E Range	one	W side	wall	bay5			face	9	4	4a1	up	clear
E Range	one	W side	wall	bay6			face	4	1	4a1	up	clear
E Range	one	W side	wall	bay6			face	5	2	4a1	up	clear
<b>4a2</b>												
E Range	one	W side	wndw	EW0.5	mull2	lwr	mould	2	1	4a2	up	clear
<b>4a3</b>												
N Range	one	S side	arch	NS0.4	jmbE		face	4	1	4a3	up	worn



4b1												
SW Range	three	Attic	chimney	SWCh1	wall E		face	4	1	4b1	sde	clear
SW Range	three	Attic	wndw	SWW2.11	mull2	uppr	mould	1	1	4b1	up	clear
W Range	two	E side	door	WED1.0	jmbE		face	5	1	4b1	sde	clear
4b10												
SW Range	three	Lessr Str	bay1W	cornice		uppr	face	3	1	4b10	up	worn
SW Range	two	Passage	wndw	SWE1.6	jmbN	uppr	mould			4b10	up	worn
4b20												
SW Range	two	BBed Ch	wndw	SWW1.14	mull3	lwr	mould	1	1	4b20	sde rev	dam
SW Range	one	Lobby	door	DN1	archt	lwr	mould	1	1	4b20	up	clear
SW Range	one	Lobby	door	DN2	crnce	uppr	mould	1	1	4b20	sde rev	clear
SW Range	one	Lobby	door	DN2	archt	lwr	mould	1	2	4b20	up	clear
SW Range	one	Pallt Ch	frieze	bay1		SWW0.9	lwr		1	4b20	sde	clear
4b22												
S Range	one/two	N side	wndw	SN0.4	mull1	lvl 4	mould	1	1	4b22	up	clear
4b24												
W Range	one/two	E side	pilaster	PL1	flute		fillet3	3	1	4b24	up	worn
4bq1												
S Range	one/two	N side	wndw	SN0.4	mull1	lvl 1	mould	1	1	4bq1	up	clear
4f1												
S Range	one	Buttery	Blkd feature	BTW0.1		infill	face	1	4	4f1	up	worn
4g10												
S Range	one	Porch	wall	PWI	W Wall		face	12	4	4g10	angl	worn
4g9												
S Range	one	Porch	wall	PEI	E Wall		face	9	2	4g9	up	worn
4gv1												
W Range	two	E side	wall	bay2	S end		face	4	6	4gv1	up	worn
4h1												
E Range	one	W side	wndw	EW0.1	jmbN	lwr	mould	2	1	4h1	up	clear
N Range	one	S side	arch	NS0.1	jmbW		face	4	1	4h1	inv	worn
S Range	two	Porch	wall	PEEx	E Wall		face	2	4	4h1	sde	clear
S Range	two	Porch	wall	PEEx	E Wall		face	3	1	4h1	sde	clear
S Range	two	Porch	wall	PEEx	E Wall		face	3	4	4h1	sde	worn
S Range	two	Porch	wall	PWEx	W Wall		face	2	4	4h1	sde	worn
S Range	two	Porch	wall	PWEx	W Wall		face	2	2	4h1	sde	worn
S Range	two	Porch	wall	PWEx	W Wall		face	2	3	4h1	sde	worn
S Range	two	Porch	wall	PWEx	W Wall		face	4	6	4h1	sde	worn
S Range	two	Porch	wall	PWEx	W Wall		face	5	3	4h1	sde	worn
S Range	two	Porch	wall	PWEx	W Wall		face	8	2	4h1	sde	worn
W Range	one	W side	wndw	WW0.7	mull1	uppr	mould	1	1	4h1	angl	clear
4m1												
SW Range	three	Attic	chimney	SWCh1	wall E		face	3	1	4m1	sde	clear
SW Range	one	Pallt Ch	wall	Q1E			face	1	1	4m1	sde	clear
SW Range	one	Passage	wndw	SWE0.2	embrE		face			4m1	inv	clear
4m10												
E Gate	one	N side	arch	wall	uppr	centre	face	4	1	4m10	up	clear
4m23												
E Gate	one	W side	arch	pier	rebate		face	3	1	4m23	up	worn
4m5												
E Gate	one	W side	arch	niche S	arch	soffit	face	1	2	4m5	up	worn
4p12												
E Gate	one	E side	arch	niche N	back wall		face	5	2	4p12	sde	worn
S Range	one	N side	wall	bay1	NE corner	lwr	face	2	1	4p12	inv	worn
S Range	one	Porch	wall	PNI	N Wall		face	6	1	4p12	rev	clear
S Range	one	Porch	wall	PWI	W Wall		face	6	4	4p12	angl	worn
4p7												
E Gate	one	E side	arch	niche N	arch	voussr	face	V2		4p7	up	worn
4pd1												
S Range	one/two	N side	wndw	SN0.3	mull2	lvl 5	mould	1	1	4pd1	up	clear
W Range	one/two	E side	pilaster	PL3	flute		fillet4	6	1	4pd1	up	worn
W Range	one/two	E side	pilaster	PL3	flute		fillet3	14	1	4pd1	up	worn
4q2												
E Range	one	W side	wndw	EW0.1	sill	int	mould	1	1	4q2	up	clear
4q7												
E Range	two	E side	wall	EEES	quoin W		face	10	1	4q7	up	clear
E Range	two	E side	wall	EEES	quoin E		face	6	1	4q7	up	worn
E Range	two	E side	corbel	EES1	SE corner		face	1	1	4q7	sde	clear
S Range	one/two	S side	chimney	SSCh1	W side	quoin	face	5	1	4q7	sde	worn

SW Range	three	Attic	centre wall	S face	wall	lwr	face	3	1	4q7	angl	worn
SW Range	three	Attic	centre wall	W face	wall	lwr	face	2	1	4q7	angl	clear
SW Range	one	E side	wall	bay2		NE corner	face	1	6	4q7	sde	clear
SW Range	one	E side	wall	bay2		NE corner	face	5	5	4q7	up	worn
SW Range	zero	E side	wall	bay2		quoin	face	3	1	4q7	up	worn
SW Range	one/two	Gt Stair	rail	L2N		uppr	rear	2	1	4q7	sde	clear
SW Range	one/two	Gt Stair	rail	L2N		uppr	rear	3	1	4q7	up	clear
SW Range	zero	Lessr Str	door	DW1	jmbN		mould	4	1	4q7	up	clear
SW Range	zero	Libry	wndw	SWW-0.14	3.1	infill	face	2	1	4q7	angl	worn
SW Range	zero	Libry	wndw	SWW-0.14	3.2	infill	face	2	1	4q7	sde	clear
SW Range	zero	Libry	wndw	SWW-0.14	2.1	infill	face	3	1	4q7	sde	clear
SW Range	one	Lobby	door	DN2	crnce	uppr	mould	1	3	4q7	up	worn
SW Range	one	Passage	wall	N of door	W wall		face	2	5	4q7	up	clear
SW Range	one	Passage	wall	N of door	W wall		face	3	2	4q7	up	worn
SW Range	one	S side	wall	bay1	SW corner		face	2	3	4q7	angl	clear
SW Range	one	S side	wall	bay1	SW corner		face	3	3	4q7	angl	clear
SW Range	one	S side	wall	bay2	S wall		face	3	2	4q7	angl	clear
SW Range	one	S side	wall	bay2	S wall		face	4	3	4q7	sde	clear
SW Range	one	S side	wall	bay2	S wall		face	5	3	4q7	sde	worn
SW Range	one	S side	wall	bay2	S wall		face	8	3	4q7	angl	clear
SW Range	one	S side	wall	bay2	S wall		face	8	2	4q7	up	worn
SW Range	zero	S side	wall		S wall		face	5	2	4q7	sde	clear
SW Range	zero	S side	wall		SE wall		face	6	1	4q7	sde	clear
W Gate	one	W side	arch	niche S	back wall		face	7	1	4q7	up	clear
4r1	one	Gt Parlor	wndw	SWW0.6	mull1	lwr	mould	1	1	4r1	up	dam
SW Range	one	Lessr Str	frieze	N side	brdr	lwr	face	1	5	4r1	sde inv	clear
SW Range	one	Libry	wndw	SWW0.14	jmbE	uppr	mould	2	1	4r1	up	clear
W Range	one	E side	wndw	WE0.3	jmbN	lwr	mould	2	1	4r1	up	obsc
4r4	one	E side	arch	niche N	arch	voussr	face	V4		4r4	up	worn
E Gate	one	W side	arch	niche N	arch	soffit	face	1	2	4r4	up	clear
4t7	one	S side	arch	NS0.1	jmbE		face	1	1	4t7	up	clear
4v20	one	W side	wndw	WW0.4	jmbN	lwr	mould	1	1	4v20	up	worn
4v8	two	W side	wndw	EW1.2	jmbN	uppr	mould	2	1	4v8	sde	dam
E Range	one	N side	wndw	NN0.7	embrE		face	2	1	4v8	sde	clear
N Range	one	N side	corner	NSStE	E side		face	1	1	4v8	up	clear
N Range	two	N side	wndw	NN1.2	embrE		face	3	1	4v8	sde	clear
N Range	one	S side	arch	NS0.3	arch	voussr	face	V2E		4v8	up	clear
S Range	two	Buttery	Blkd feature	BTW1.1	jmbS		face	4	1	4v8	up	worn
S Range	one/two	N side	wndw	SN0.2	embrS	lvl 1	face	2	1	4v8	angl	clear
S Range	one/two	N side	wndw	SN0.3	mull2	lvl 4	mould	1	1	4v8	up	worn
S Range	one/two	N side	wndw	SN0.4	embrW	lvl 1	face	1	1	4v8	sde	clear
S Range	one/two	N side	wndw	SN0.4	embrE	lvl 1	face	1	1	4v8	up	clear
S Range	one/two	N side	wndw	SN0.5	jmbW	lvl 1	mould	1	1	4v8	up	clear
S Range	one/two	N side	wndw	SN0.5	mull2	lvl 1	mould	1	1	4v8	up	clear
SW Range	one	Bllds Rm	wndw	SWW0.15	mull4	midd	mould	1	1	4v8	up	clear
SW Range	one	Pallt Ch	wall	Q4E			face	11	1	4v8	up	dam
SW Range	two	Passage	wndw	SWE1.5	jmbE	uppr	mould			4v8	up	clear
W Range	one	E side	frieze	bay1	S end	border	lwr			4v8	up	clear
W Range	one	E side	frieze	bay2	WE0.5	border	lwr	1	5	4v8	up	worn
W Range	one	E side	wndw	WE0.5	jmbS	lwr	mould	2	1	4v8	up	worn
W Range	one/two	E side	pilaster	PL1	flute		fillet3	4	1	4v8	up	worn
W Range	one	W side	wndw	WW0.5	jmbN	lwr	mould	2	1	4v8	up	worn
W Range	one	W side	wndw	WW0.7	jmbN	lwr	mould	1	1	4v8	up	clear
W Range	two	W side	wndw	WW1.6	jmbN	uppr	mould	1	1	4v8	up	clear
W Range	two	W side	wndw	WW1.6	jmbS	uppr	mould	2	1	4v8	up	clear
4w1	one	E side	setback	NNE0.1	embrN		face	5	1	4w1	up	clear
4w2	two	E side	wndw	EEE1.2	jmbN		mould	3	1	4w2	sde	clear









S Range	one/two	S side	chimney	SSCh1	W side	quoin	face	4	1	6v82	up	worn
SW Range	one/two	Lessr Str	rail	F1N		uppr	rear	1	1	6v82	sde	clear
<b>6w10</b>												
E Gate	one	E side	arch	niche N	arch	spandrel S	face	1	1	6w10	sde	worn
W Gate	one	E side	arch	niche N	back wall		face	6	2	6w10	inv	worn
<b>6x10</b>												
N Range	three	N side	wall	GNN	W side		face	1		6x10	up	clear
SW Range	zero	Lessr Str	door	DW1	jmbN		mould	2	1	6x10	sde	clear
<b>6x11</b>												
E Gate	one	N side	arch	wall	uppr	centre	face	5	1	6x11	up	clear
<b>6xt1</b>												
N Range	one	S side	arch	NS0.3	arch	keyst	face	V6		6xt1	up	worn
<b>7ah1</b>												
E Range	one	W side	wall	bay4			face	10	2	7ah1	up	clear
E Range	one	W side	wall	bay5			face	10	4	7ah1	up	clear
E Range	one	W side	wall	bay6			face	7	4	7ah1	inv	worn
E Range	one	W side	wall	bay6			face	8	6	7ah1	up	clear
E Range	one	W side	wall	bay6			face	10	4	7ah1	inv	clear
N Range	one	S side	arch	NS0.1	jmbW		face	1	3	7ah1	up	clear
<b>7gv14</b>												
S Range	one	Porch	wall	PEI	E Wall		face	11	5	7gv14	up	worn
S Range	one	Porch	wall	PEI	E Wall		face	9	5	7gv14	up	worn
S Range	one	Porch	wall	PEI	E Wall		face	11	4	7gv14	up	worn
S Range	one	Porch	wall	PWEx	W Wall		face	6	4	7gv14	up	worn
S Range	one	Porch	wall	PWI	W Wall		face	3	3	7gv14	up	clear
S Range	one	Porch	wall	PWI	W Wall		face	7	5	7gv14	up	clear
<b>7gv4</b>												
S Range	one	Porch	wall	PEI	E Wall		face	5	3	7gv4	up	worn
S Range	one	Porch	wall	PWI	W Wall		face	11	2	7gv4	up	worn
S Range	one	Porch	wall	PWI	W Wall		face	8	2	7gv4	up	clear
<b>7m5</b>												
E Gate	one	E side	arch	niche N	embrS		face	3	2	7m5	sde	worn
E Range	one/two	W side	pilaster	PL1	flute		fillet3	2	1	7m5	up	worn
E Range	one/two	W side	pilaster	PL1	flute		fillet3	7	1	7m5	up	worn
E Range	one/two	W side	pilaster	PL1	flute		fillet5	14	1	7m5	up	worn
E Range	one/two	W side	pilaster	PL2	flute		fillet4	2	1	7m5	up	worn
E Range	one/two	W side	pilaster	PL2	flute		fillet4	2	1	7m5	up	worn
E Range	one/two	W side	pilaster	PL2	flute		fillet4	4	1	7m5	rev	worn
E Range	one/two	W side	pilaster	PL3	flute		fillet4	4	1	7m5	up	worn
N Range	one	N side	frieze	bay1	centre		face	1	1	7m5	inv	worn
N Range	one	N side	frieze	bay1	centre		face	1	9	7m5	inv	worn
N Range	one	N side	frieze	bay1	centre		face	1	11	7m5	inv	worn
N Range	one	N side	frieze	bay2	centre		face	1	16	7m5	up	worn
N Range	one	N side	frieze	bay2	centre		face	1	17	7m5	up	worn
N Range	one	N side	frieze	bay2	centre		face	1	19	7m5	up	clear
N Range	one	N side	wall	bay3	W side		face	9		7m5	up	clear
N Range	one	N side	frieze	bay3	centre		face	1	24	7m5	inv	clear
N Range	one	N side	frieze	bay5	centre		face	1	2	7m5	inv	worn
N Range	one	N side	frieze	bay6	centre		face	1	9	7m5	inv	worn
N Range	one	N side	frieze	bay6	centre		face	1	4	7m5	up	worn
N Range	one	N side	frieze	bay6	centre		face	1	10	7m5	up	clear
N Range	one	N side	frieze	bay6	centre		face	1	11	7m5	up	worn
N Range	one	N side	frieze	bay6	centre		face	1	12	7m5	up	clear
N Range	one	N side	frieze	bay7	brket3-4		face	1	1	7m5	up	clear
N Range	two	N side	frieze	bay1	metope 11		face	1	1	7m5	inv	worn
N Range	two	N side	wall	bay6	E side	quoin	face	3	1	7m5	inv	worn
N Range	two	N side	wall	NNW1.2	E side		face	1	2	7m5	up	clear
N Range	two	N side	wall	NNW1.2	E side		face	1	1	7m5	up	clear
N Range	one/two	S side	pilaster	PL1	flute		fillet3	5	1	7m5	inv	worn
N Range	one/two	S side	pilaster	PL5	flute		fillet3	10	1	7m5	inv	worn
N Range	one/two	S side	pilaster	PL5	flute		fillet4	12	1	7m5	up	worn
S Range	one/two	N side	wndw	SN0.4	jmbE	lvl 2	mould	3	1	7m5	up	worn
W Range	one	E side	wndw	WE0.1	mull2	lwr	mould	2	1	7m5	inv	dam



W Range	one	E side	wndw	WE0.5	mull2	lwr	mould	1	1	7m5	inv	worn
W Range	one/two	E side	pilaster	PL2	flute		fillet4	2	1	7m5	inv	worn
W Range	one/two	E side	pilaster	PL3	flute		fillet3	3	1	7m5	inv	worn
W Range	one/two	E side	pilaster	PL3	flute		fillet3	4	1	7m5	up	worn
W Range	one/two	E side	pilaster	PL3	flute		fillet3	4	1	7m5	up	worn
<b>7p24</b>												
S Range	one	Porch	wall	PEEx	E Wall		face	5	1	7p24	up	clear
<b>7p5</b>												
E Range	one	W side	wall	bay3			face	10	2	7p5	up	worn
S Range	two	Porch	wall	PEEx	E Wall		face	1	2	7p5	angl	worn
<b>7t2</b>												
E Range	one	W side	wndw	EW0.4	jmbS	lwr	mould	2	1	7t2	up	worn
<b>7vh1</b>												
S Range	one/two	N side	wndw	SN0.5	jmbE	lvl 1	mould	1	1	7vh1	up	clear
<b>7x10</b>												
E Range	one	W side	wall	bay4			face	10	3	7x10	up	clear
S Range	one	Porch	wall	PWEx	W Wall		face	8	3	7x10	up	worn
S Range	one	Porch	wall	PWEx	W Wall		face	9	3	7x10	rev	worn
<b>7x7</b>												
S Range	one	Porch	wall	PNI	N Wall		face	7	1	7x7	up	clear
<b>7xy1</b>												
S Range	one	Porch	wall	PEI	E Wall		face	2	2	7xy1	up	worn
<b>8gv7</b>												
S Range	one	Porch	wall	PWI	W Wall		face	8	3	8gv7	up	worn
<b>8gv8</b>												
S Range	one	Porch	wall	PWI	W Wall		face	9	3	8gv8	up	worn
<b>8m6</b>												
E Gate	one	E side	arch	niche N	back wall		face	7	1	8m6	up	clear
N Range	one	N side	frieze	bay2	centre		face	1	12	8m6	up	clear
N Range	one	N side	frieze	bay2	centre		face	1	15	8m6	up	clear
N Range	one	N side	frieze	bay2	centre		face	1	18	8m6	up	clear
N Range	one	N side	frieze	bay2	centre		face	1	20	8m6	inv	worn
N Range	one	N side	frieze	bay5	centre		face	1	3	8m6	up	clear
N Range	one	N side	frieze	bay6	centre		face	1	8	8m6	up	worn
N Range	one	N side	frieze	bay6	centre		face	1	13	8m6	up	clear
N Range	one	N side	frieze	bay6	centre		face	1	14	8m6	up	clear
<b>8mt1</b>												
W Range	one	E side	wndw	WE0.4	jmbS	lwr	mould	3	1	8mt1	up	clear
W Range	one	E side	wndw	WE0.4	jmbN	uppr	mould	4	1	8mt1	up	clear
<b>8vg8</b>												
S Range	one	Porch	wall	PWI	W Wall		face	9	4	8vg8	up	clear
<b>8vj1</b>												
W Range	one	W side	fplace	Wfp0.3	lintel		face	1	1	8vj1	up	worn
<b>8vx1</b>												
W Gate	one	W side	arch	niche N	back wall		face	6	1	8vx1	up	worn
<b>8x11</b>												
S Range	one	Porch	wall	PWI	W Wall		face	10	1	8x11	sde	worn
<b>8x3</b>												
S Range	one	Porch	wall	PEEx	E Wall		face	5	2	8x3	angl	worn
S Range	one	Porch	wall	PEI	E Wall		face	4	4	8x3	sde	worn
S Range	one	Porch	wall	PWI	W Wall		face	12	5	8x3	angl	clear
<b>9gv6</b>												
S Range	one	Porch	wall	PEI	E Wall		face	3	3	9gv6	up	worn
S Range	one	Porch	wall	PEI	E Wall		face	4	2	9gv6	up	clear
S Range	one	Porch	wall	PNI	N Wall		face	4	1	9gv6	up	worn
<b>9wp1</b>												
S Range	one	Porch	wall	PNI	N Wall		face	14	1	9wp1	sde	clear
<b>9wp2</b>												
S Range	one	Porch	wall	PNI	N Wall		face	13	1	9wp2	up	clear
<b>9x10</b>												
SW Range	one/two	Gt Stair	rail	F1N		uppr	rear	2	1	9x10	up	worn
SW Range	one/two	Gt Stair	rail	F1N		uppr	rear	5	1	9x10	sde	clear
<b>9x12</b>												
E Range	one	W side	wall	bay6			face	9	1	9x12	up	clear
E Range	one	W side	wall	bay6			face	8	1	9x12	up	clear
S Range	one	Porch	wall	PEEx	E Wall		face	8	5	9x12	up	clear
S Range	one	Porch	wall	PEEx	E Wall		face	7	5	9x12	sde	worn
S Range	one	Porch	wall	PEI	E Wall		face	8	5	9x12	inv	clear



S Range	one	Porch	wall	PEI	E Wall	face	8	1	9x12	up	worn
S Range	one	Porch	wall	PEI	E Wall	face	6	3	9x12	sde	worn
S Range	one	Porch	wall	PEI	E Wall	face	6	4	9x12	up	clear
S Range	one	Porch	wall	PEI	E Wall	face	11	3	9x12	up	clear
S Range	one	Porch	wall	PEI	E Wall	face	8	2	9x12	up	clear
S Range	one	Porch	wall	PEI	E Wall	face	9	3	9x12	up	worn
S Range	one	Porch	wall	PWEx	W Wall	face	5	4	9x12	sde	worn
S Range	one	Porch	wall	PWEx	W Wall	face	8	2	9x12	rev	worn
S Range	one	Porch	wall	PWEx	W Wall	face	6	5	9x12	up	worn
S Range	one	Porch	wall	PWEx	W Wall	face	5	3	9x12	up	worn
S Range	one	Porch	wall	PWEx	W Wall	face	8	1	9x12	up	worn
S Range	one	Porch	wall	PWI	W Wall	face	7	2	9x12	up	clear
S Range	one	Porch	wall	PWI	W Wall	face	7	4	9x12	angl	clear