

investing
in **your** future
European Regional Development Fund
European Union



www.advantagem.co.uk



Opening of the Science City Cleanroom for Energy Efficient Semiconductors

Prof. Phil Mawby

2nd July 2010

THE UNIVERSITY OF
WARWICK

HEALTH EDUCATION
FUNDING COUNCIL
FOR ENGLAND
hefce

UNIVERSITY OF
BIRMINGHAM

What is Electronics?

Electronics

**Information
Processing**

**Energy
Processing**

investing
in **your** future
European Regional Development Fund
European Union



www.advantagewm.co.uk

Birmingham Science City
ideasforlife 

Power Electronics

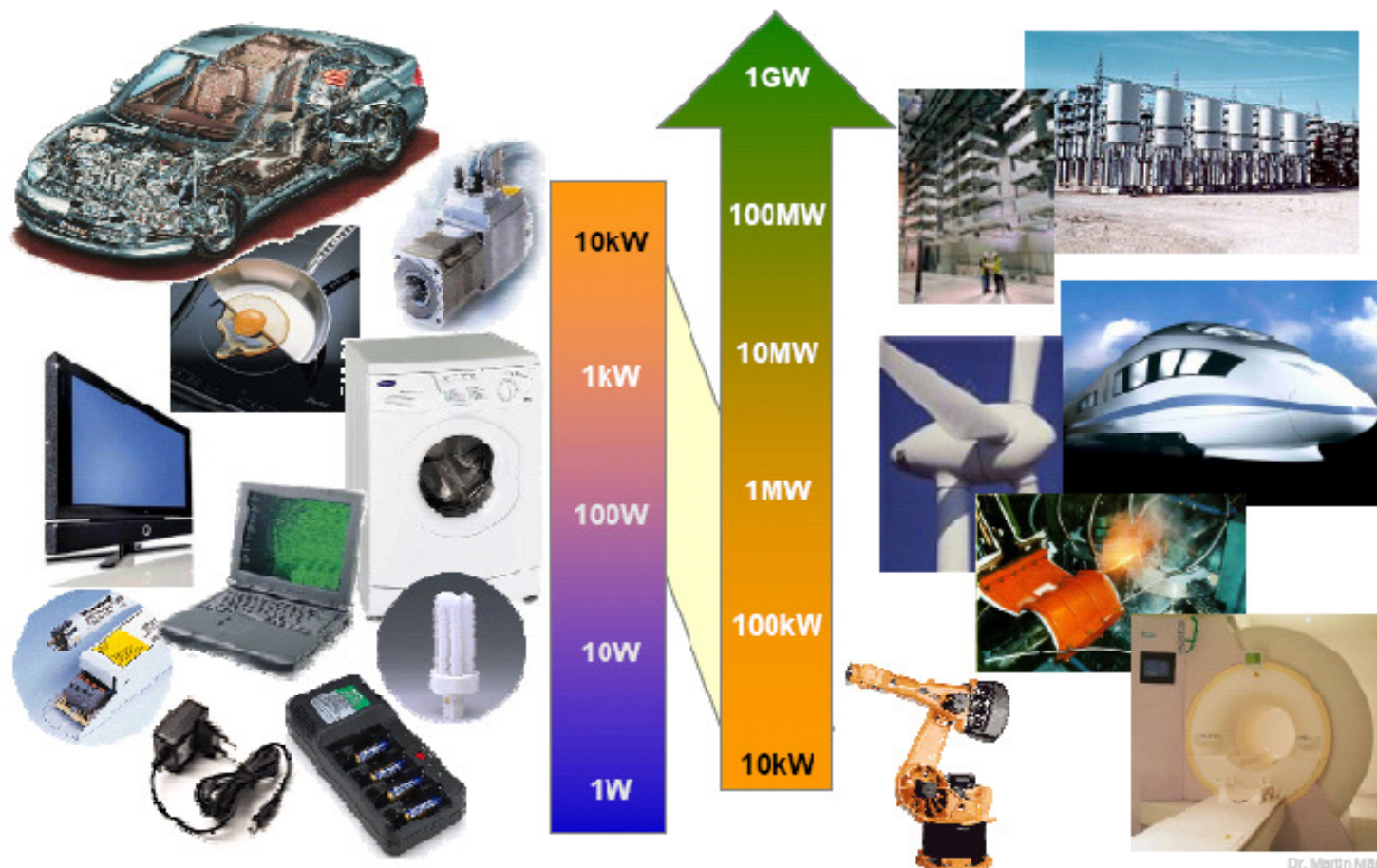

Electrification of Road Transport



Simple electrical drive system

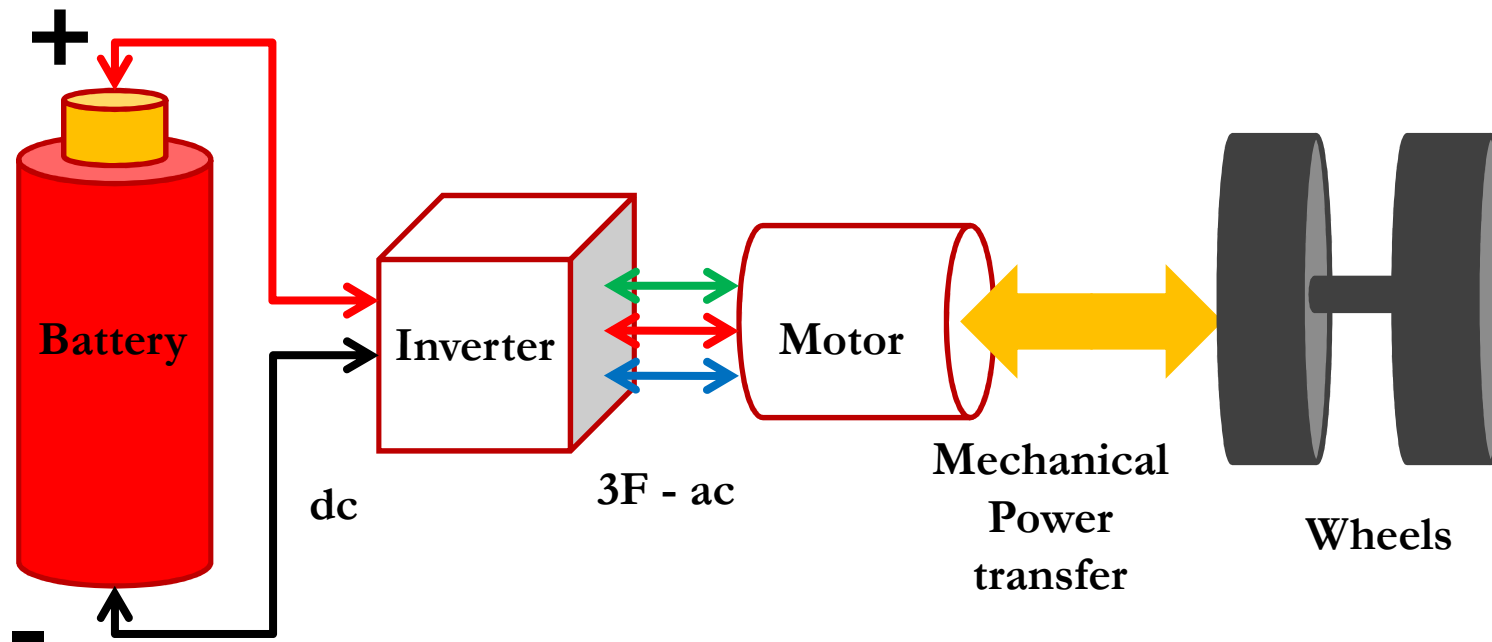

Main Drive Power Electronics

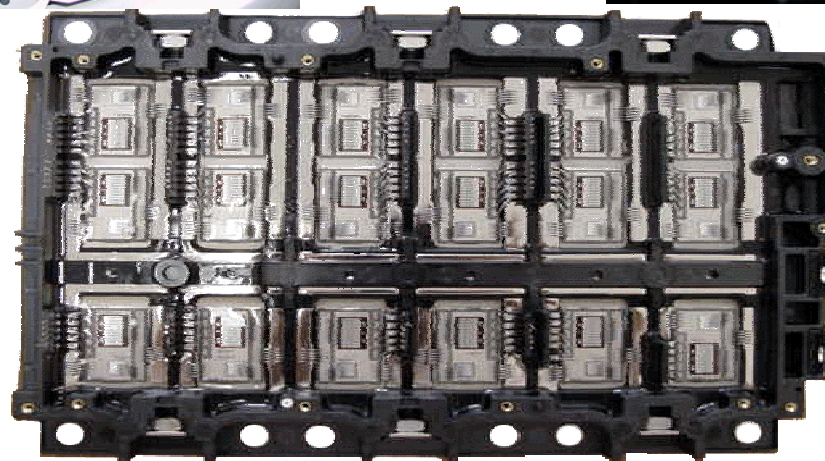

Aerospace





Queen Mary 2 - electric propulsion system: 4 pods totalling 86MW.

Renewable Energy

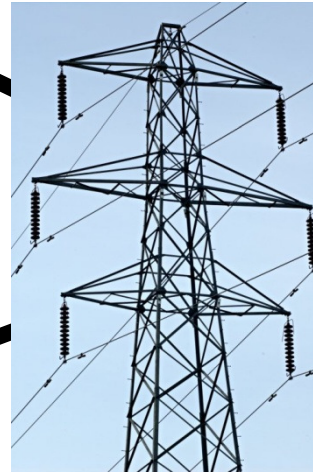

Power Electronics
Make Renewable energy possible

Possible Future Energy Systems

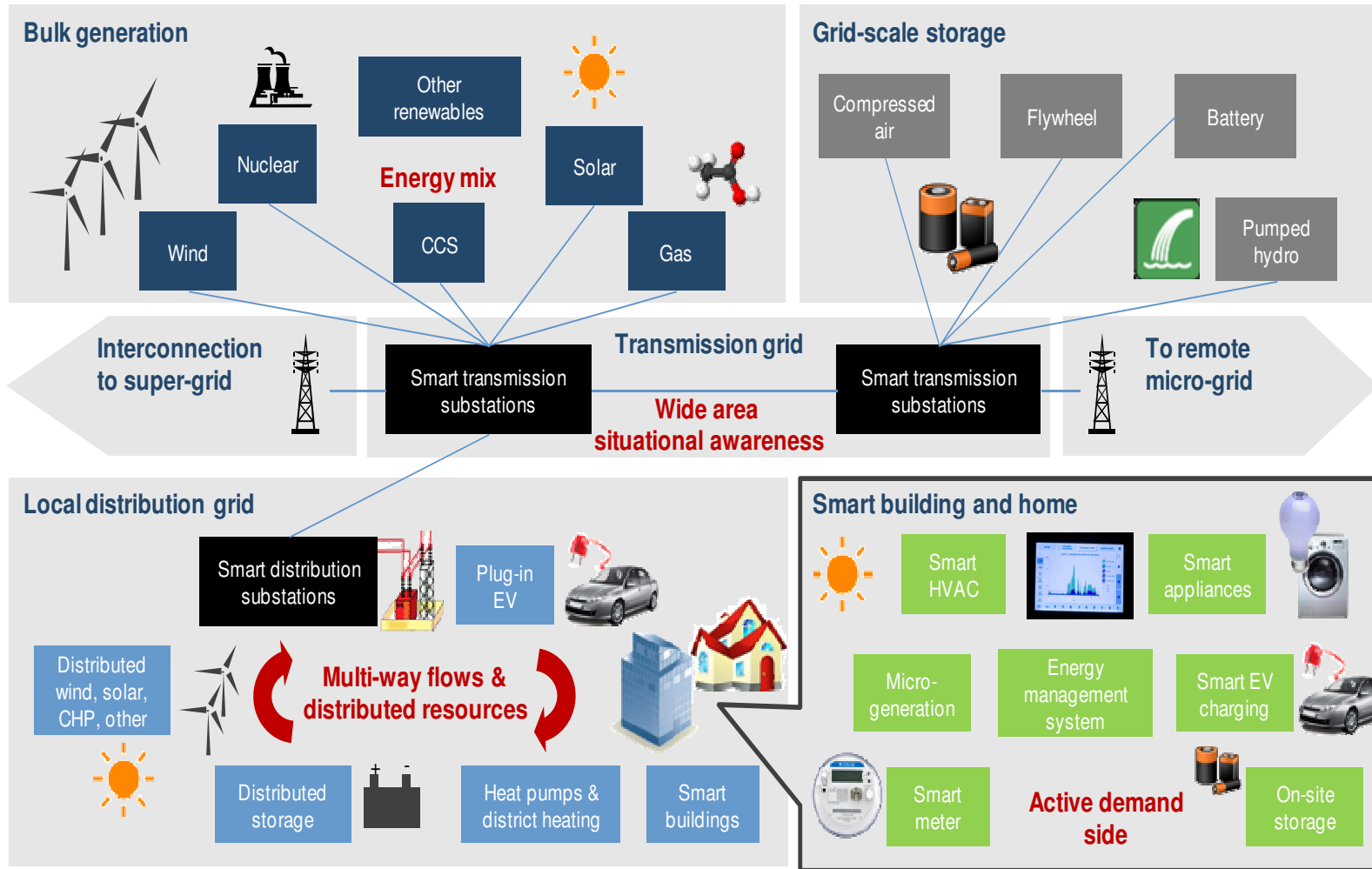

Various components of the future electricity network at the generation, transmission and distribution levels.
 Source – Bloomberg Consortium on Digital Energy 2010

Application in HVDC System



Silicon Carbide Properties

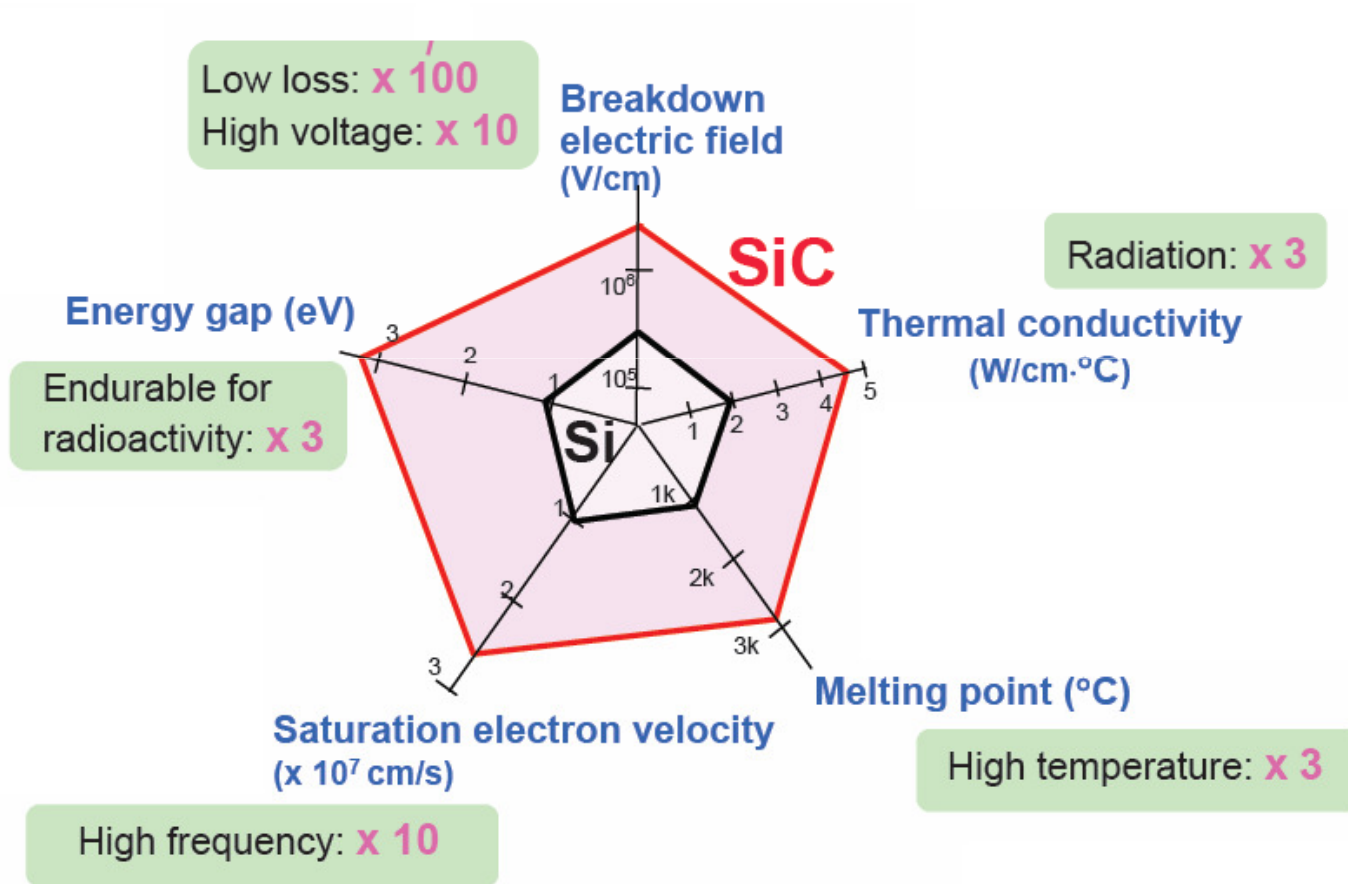

Power Electronics

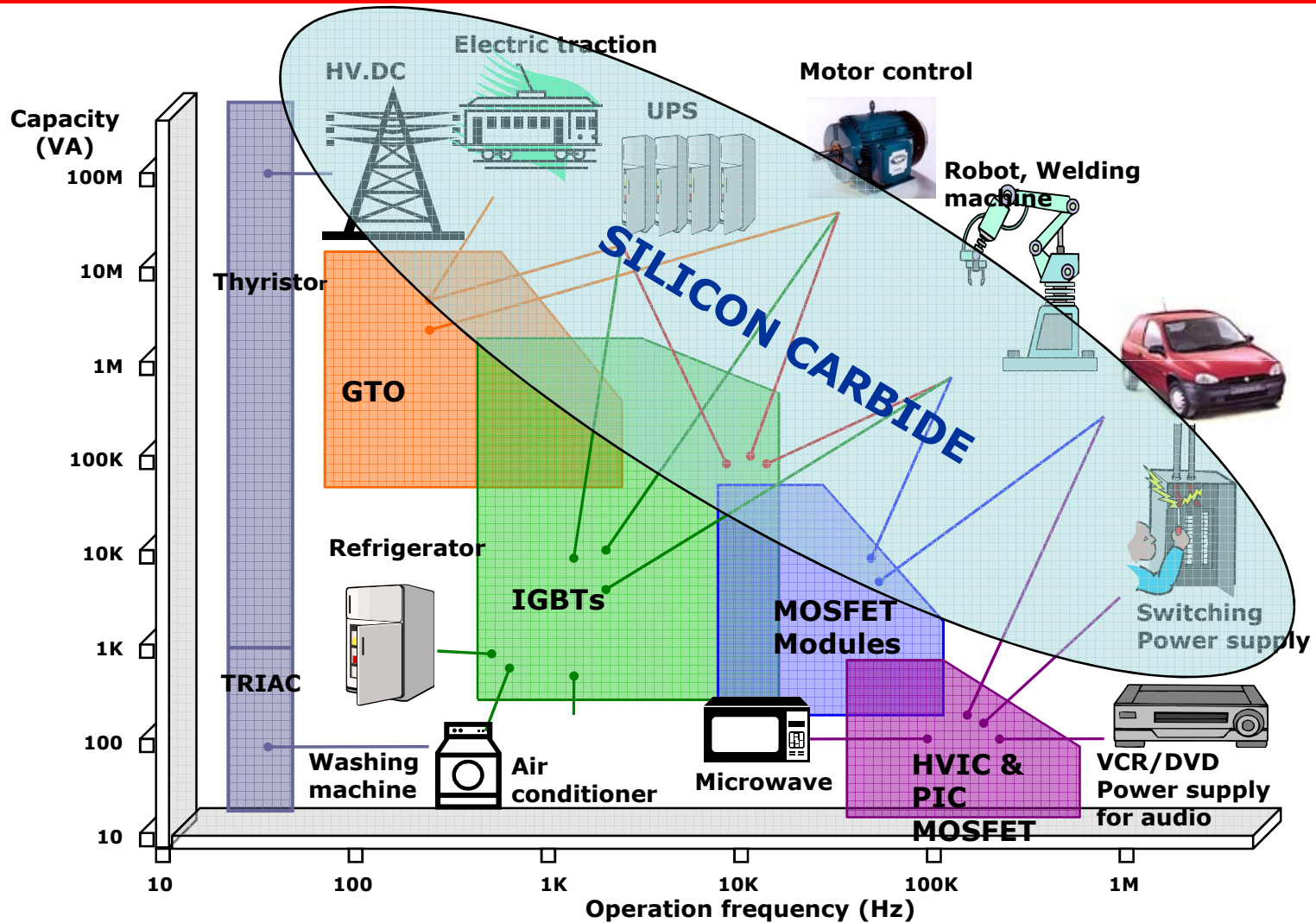

Silicon Carbide Wafer

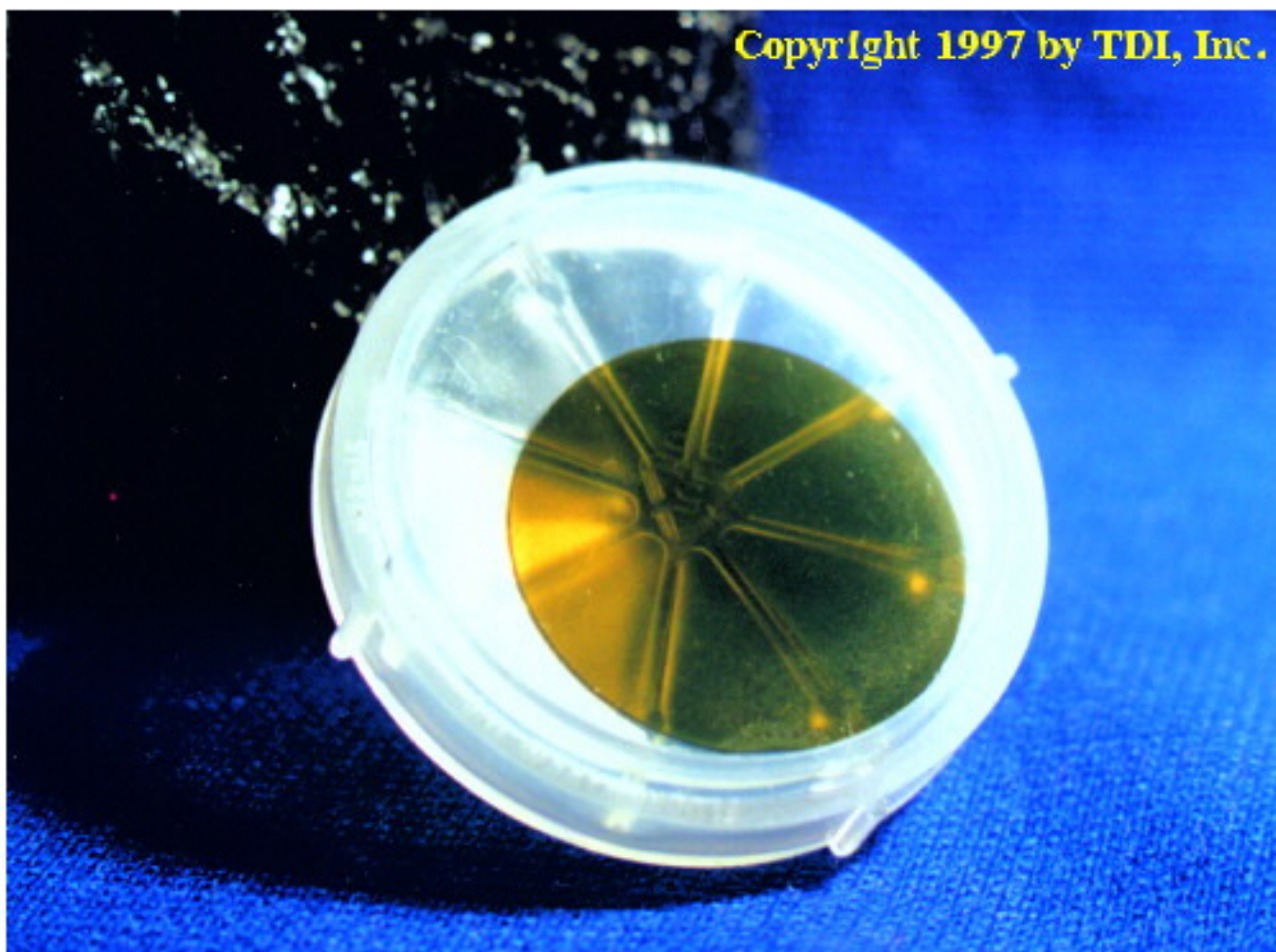

Limitation of power electronics

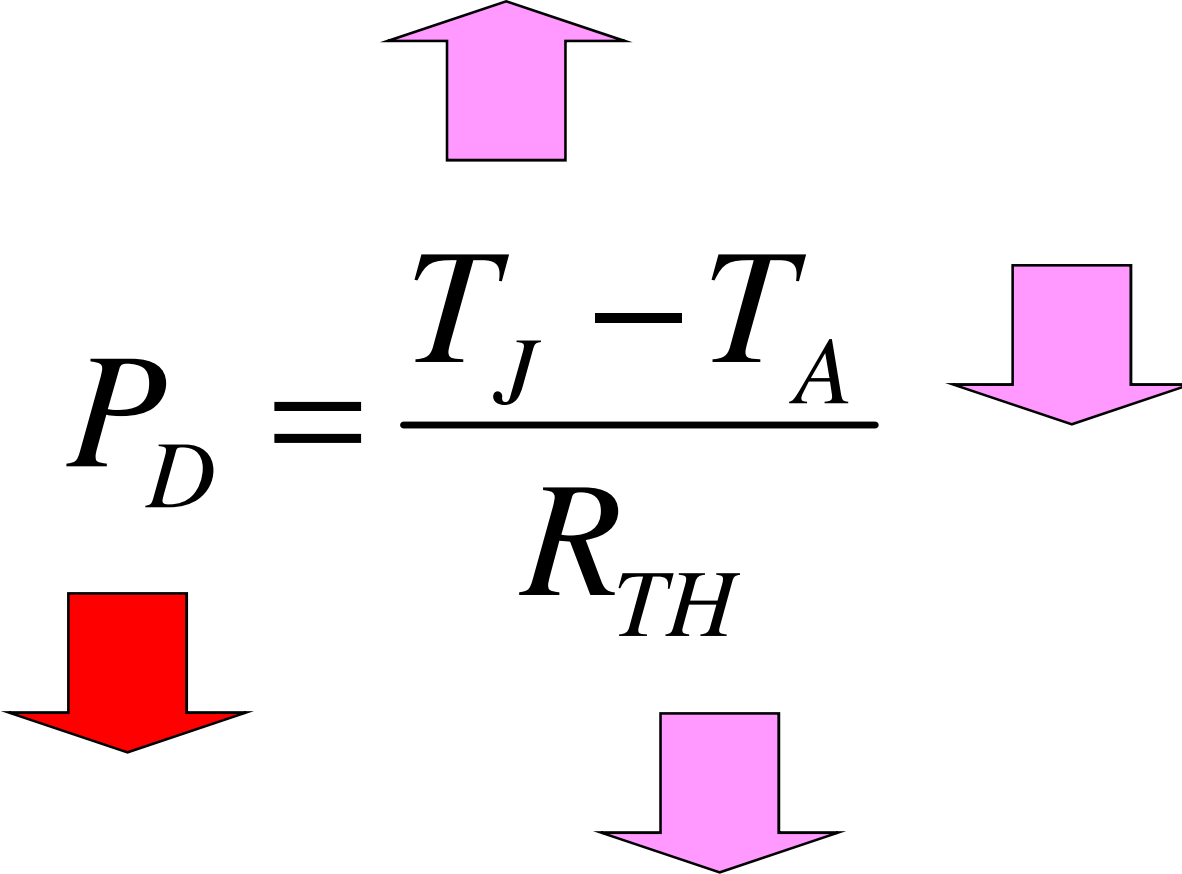
$$P_D = \frac{T_J - T_A}{R_{TH}}$$

SiC Technological Problems

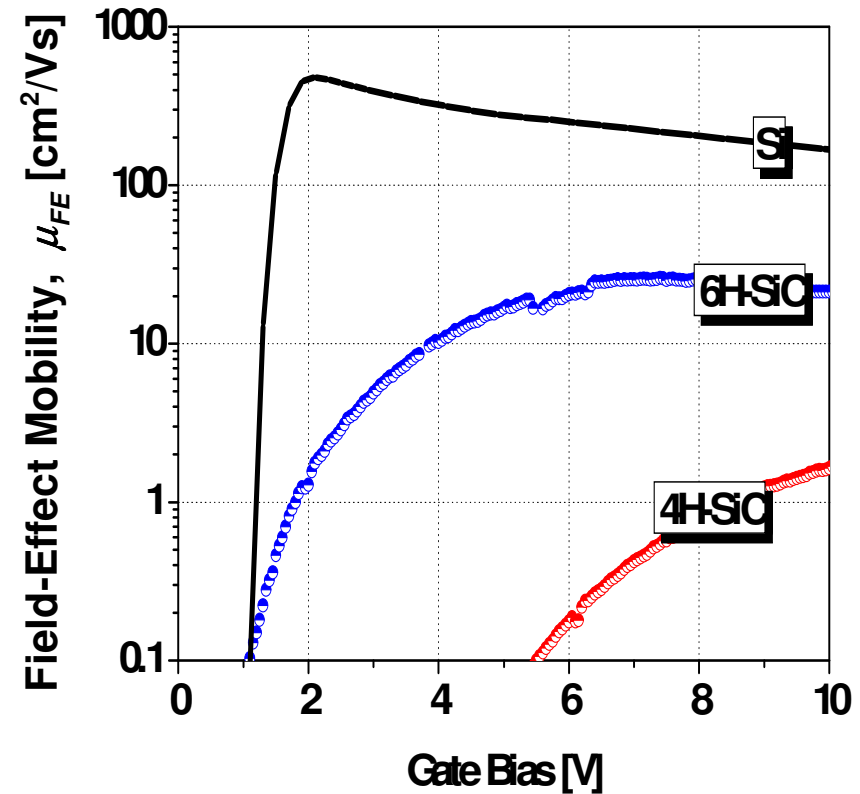
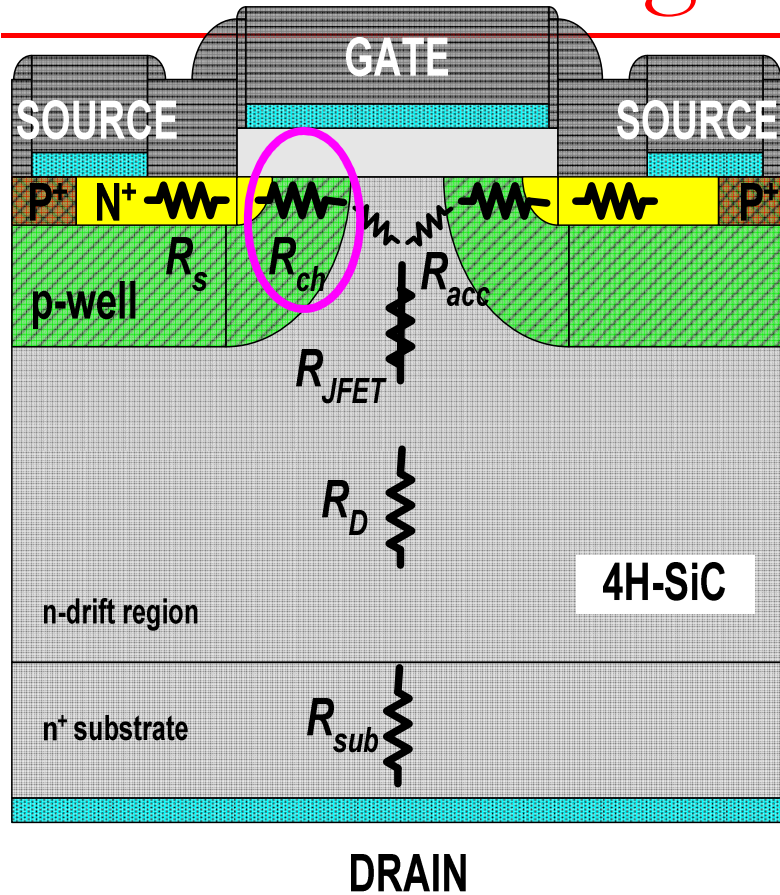

Cleanroom Equipment



Stepper

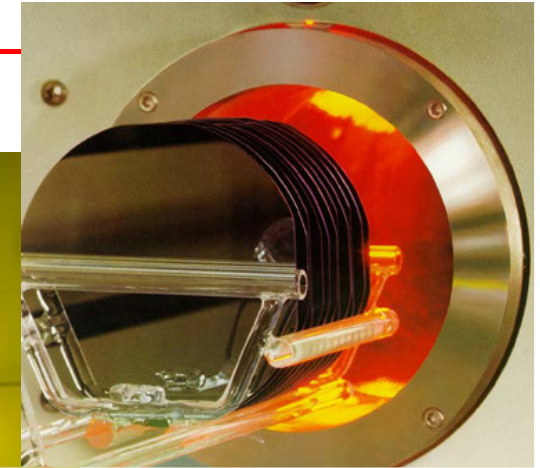

High Temperature oxidation Furnace



ICP RIE system

Metal Sputterer

GVC 401 Sputtering System



Contacts

- ❑ Prof Phil Mawby, UofW academic lead
p.a.mawby@warwick.ac.uk
- ❑ Prof Richard Green, UofB academic lead
r.j.green@bham.ac.uk
- ❑ Sarah Key-Bright, Project Manager
s.keay-bright@warwick.ac.uk
07842 541135
- ❑ Mike Ahearne, Business Engagement Manager
M.ahearne@warwick.ac.uk
07842541173