

## ENERGY AND LOW INCOME TROPICAL HOUSING: BASIC DATA AND CONTEXTS - CHINA

### 1. Brief summary of key geographical, climatic, regulatory and socio-economic context.

Although China is amongst the high-tier developing countries, the country's rural population is almost 44% (latest data from 13<sup>th</sup> five year plan, March 2016). While China is modernising rapidly, its urbanisation pace is still rapid and in large scale. After passing the 50% rate of urban population in 2007, it is expected that China's urbanisation will reach 60% by 2020 and 70% by 2030. The shift from rural to urban will have significant impact on the country's socio-economic context and consumption rate.

Comparatively, China's population only matches India, which is another superpower of Asia. Figure 1 demonstrates the socio-economic conditions of China.

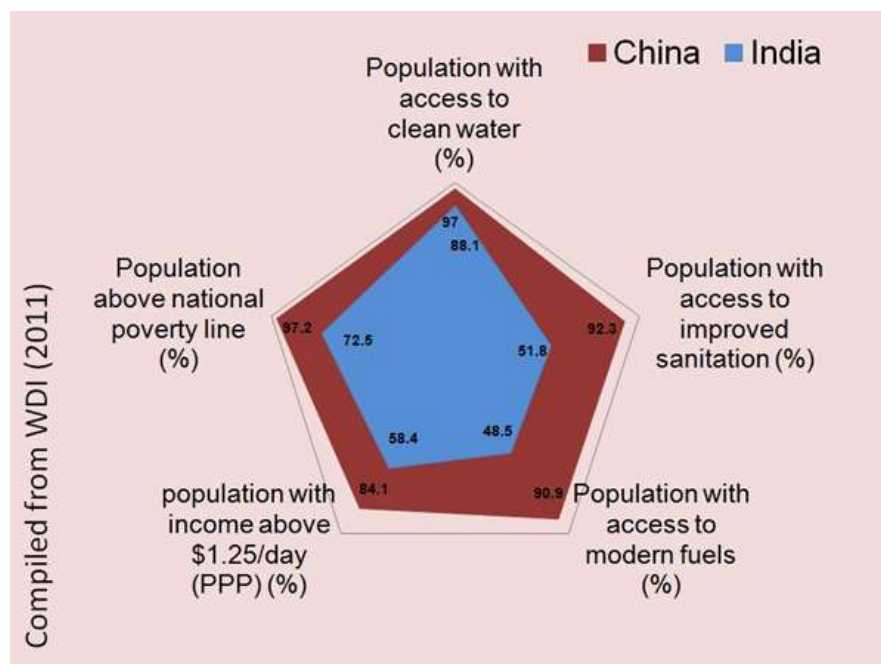

Figure 1. China's socio-economic conditions in comparison with India (compiled from WDI, 2011 – from [www.china.org.cn](http://www.china.org.cn))

Geographically, China's vast land includes several climatic zones, ranging from several cold to tropical zones (figure 2). This factor adds further complications to the country's building codes and etc. For the purpose of this project, the selected areas of study are located in two regions of tropical and sub-tropical regions. While tropical areas in China are very limited, some of the sub-tropical areas share climatic conditions with tropical zones. Mostly located in Central-East of China, this region has a hot summer, cold winter (HSCW) climatic condition. Our studied zones are located in the provinces of Guandong, Fujian, Hunan and Zhejiang.

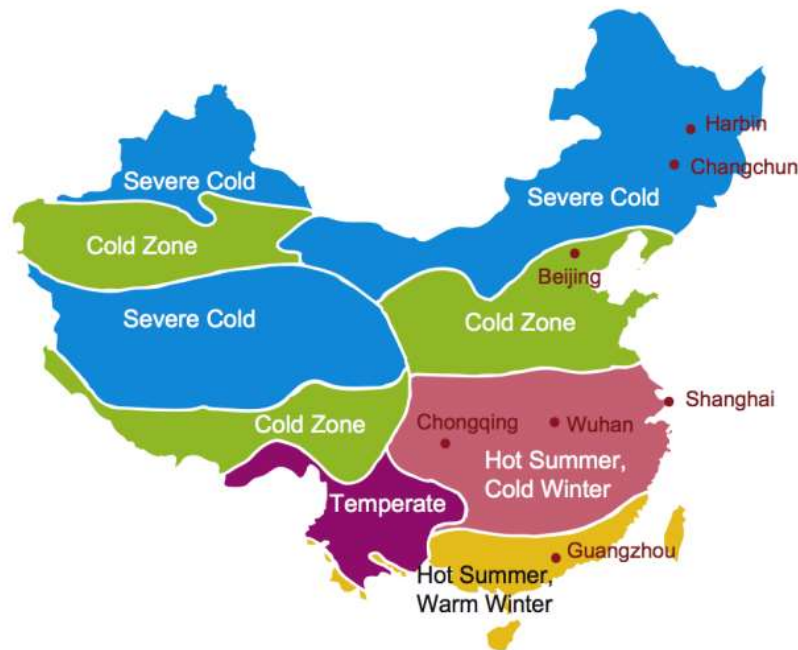

Figure 2. China's climatic zones (Source: Berkley Lab, 2014)

## ***2. Brief summary of types and features of medium and low income houses, and issues.***

Unlike the European context, there is a big difference between urban and rural housing typologies in China. For this research programme, our major focus has been on urban housing, which plays a major role in China's built environment.

Prior to 1978, urban housing was a part of the socialists' welfare system and the work unit (danwei) allocated housing free of charge to employees and their families. The housing reform in China began in 1980 and had an initial goal to solve problems resulting from housing shortage and poor quality and overcrowding housing. In the current third-stage of housing reform (1999-2006), the plan aims to realise housing commercialisation according to the principles of a socialist planned market economy. However, the government is facing other major issues, such as, inflated housing prices, affordability, bubbles and shortages. According to Xue Feiren (2013), China is now at its third stage of urban planning development; a period characterised by intensive urban renewal and redevelopment, decentralization, no public input regulations, excessive technicism, emphasis on design and construction, attracting capital investment, and functional-zoning pattern (ibid). But the main feature is deeply related to the leasing land-use rights to private developers, which become the main channel of increasing necessary financial resources for local urban renewal projects. As a consequence of substantial emphasis on urban renewal and large-scale redevelopment, the landscape of Chinese cities have changed significantly; particularly in recent years. As a result, this heterogeneity of urban development is reflecting on various housing patterns.

*China's main urban housing typologies for low to medium income groups are in the following three categories:*

**A. *Traditional low-rise housing*** – mostly located in poorer communities and low-income contexts. These are mostly built before 1980s and currently lack maintenance. Construction quality is fairly good but energy performance of this older typology is no longer efficient. In some literature, we refer to this typology as ViCs (Village in Cities). The Floor Area Ratio (FAR) of this type of housing area is often very high, approximately between 3.0 to 5.0 (or even more in extreme cases). The spatial arrangement is organic with a combination of internal and external networks. There is lack of greenery within such housing areas and many informal spaces are introduced by the residents. The Surface Coverage (SC) is very high with narrow roads and paths between the units. The density is often very low, with most buildings ranging from 1 to 6 floors. In here, we can map traditional courtyard houses, vernacular town/village houses and buildings from both Ming and Qing dynasties. The two future development possibilities for such housing areas are either renovation (for preservation and commercialisation) or redevelopment (for new housing areas). Since Xiushui community includes many protected buildings, the former is expected.

**B. *Affordable or Slab Housing*** – Started in 1988, the abolition of the work unit-based welfare oriented housing system was a milestone in China's urban housing reforms. This change in policy aimed to establish an urban housing market. It conveyed the policy that subsidised workplace housing would no longer be provided by the Chinese government. One of the consequences of this tendency was the emergence of housing affordability as a serious challenge. Nowadays, many factors help to explain why housing affordability has become a challenge to the Chinese housing reform, such as the overheating of the housing market and management. These houses mainly represent the housing development pattern and urban landscape of 1990s' with a singular land-use (i.e. residential) and minimal provision of adequate landscaping and facilities. The Floor Area Ratio (FAR) of this type of housing is often 1.0 or less, with parallel design pattern and lack of green spaces between the buildings. The Surface Coverage (SC) is less than the ViCs pattern, but is between 6 to 8 floors. Since the government has provided such housing units for the low-income people, the houses were initially subsidised for residents in the region working in the industrial zones of the area. This example is also a remarkable example of housing transition from work unit-based welfare oriented housing system to affordable housing.

**C. *Gated Community or Small Residential District (SRD)*** - Residential housing renewal have led to emerge of new community, in which gated community (Xiaoqu- residential compounds) (Tombs, 2005; Wei and Zhu, 2009) has become the standard housing pattern of the newly-built residential areas in Chinese cities. The newer xiaoqu are mostly commodity-housing projects built after 1990's. In spite of the variations, Chinese xiaoqu could be old and new, large and small, or modified work-unit housing estates, but they share one common design feature of being 'gated'. Such housing area, having all its units occupied, would often house around 3,000 to 12,000 residents, depending on the block size and density. In extreme cases more population density is recorded. The provision of retail podiums and a more mixed-use development on the edges of such housing development, help to create a mixed living environment with adequate accessibility to nearby amenities. Yet, such housing often encourages car ownership. This type of gated community development demonstrates a typical contemporary housing development pattern and

urban landscape with a mixed land-use (i.e. residential with some commercial and retail) and substantial provision of green spaces and landscaped open spaces and facilities. The Floor Area Ratio (FAR) of this type of housing often reaches 3.0 or even more, with a mixed combination of building and landscaping pattern. The surface coverage (SC) is low but heights of buildings can reach up to 34 floors (and to more 40+ in recent cases). This housing model is also a remarkable example of housing transition from traditional 6 to 8 storey housing (or even typical town housing) to dense blocks of mid-rise and high-rise houses.

### 3. Key national data on types of energy

To better understand the amount of energy to which residential houses consumes it is necessary to know what energy mix is present in the grid and what amount is being produced by China. The table below takes the past five years and provides the average energy mix from generation:

	Electricity (GWh)						Heat (TJ)					
	2013	2012	2011	2010	2009	avg	2013	2012	2011	2010	2009	avg
coal	4,110,826	3,785,022	3,723,315	3,250,409	2,940,751	3,562,065	3,353,067	3,189,110	2,969,865	2,709,365	2,462,485	2,936,778
oil	6,504	6,698	7,786	13,236	16,612	10,167	112,017	122,600	121,766	143,396	112,102	122,376
gas	90,602	85,686	84,022	69,027	50,813	76,030	134,618	107,796	91,989	91,566	81,043	101,402
biofuels	38,300	33,700	31,500	24,750	20,700	29,790	11,543	11,625	11,714	11,801	11,849	11,706
waste	12,304	10,968	10,770	9,064	-	8,621	34,912	32,254	25,819	22,084	-	23,014
nuclear	111,613	97,394	86,350	73,880	70,134	87,874						
hydro	920,291	872,107	698,945	722,172	615,640	765,831						
geothermal	109	125	125	125	125	122						
solar pv	15,451	6,344	2,604	699	279	5,075						
solar thermal	26	9	6	2	-	9						
wind	141,197	95,978	70,331	44,622	26,900	75,806						
tide	8		7	7	7	7						
other resources	-		-	-	-	-						
Total Production	5,447,231	4,994,031	4,715,761	4,207,993	3,741,961	4,621,397	3,646,157	3,463,385	3,221,153	2,978,212	2,667,479	3,195,277

(Source:

<http://www.iea.org/statistics/statisticssearch/report/?country=CHINA&product=electricityandheat&year=2010>)

Also, to better understand this then we obtain the average percentage of energy mix in the past five years. This is shown below:

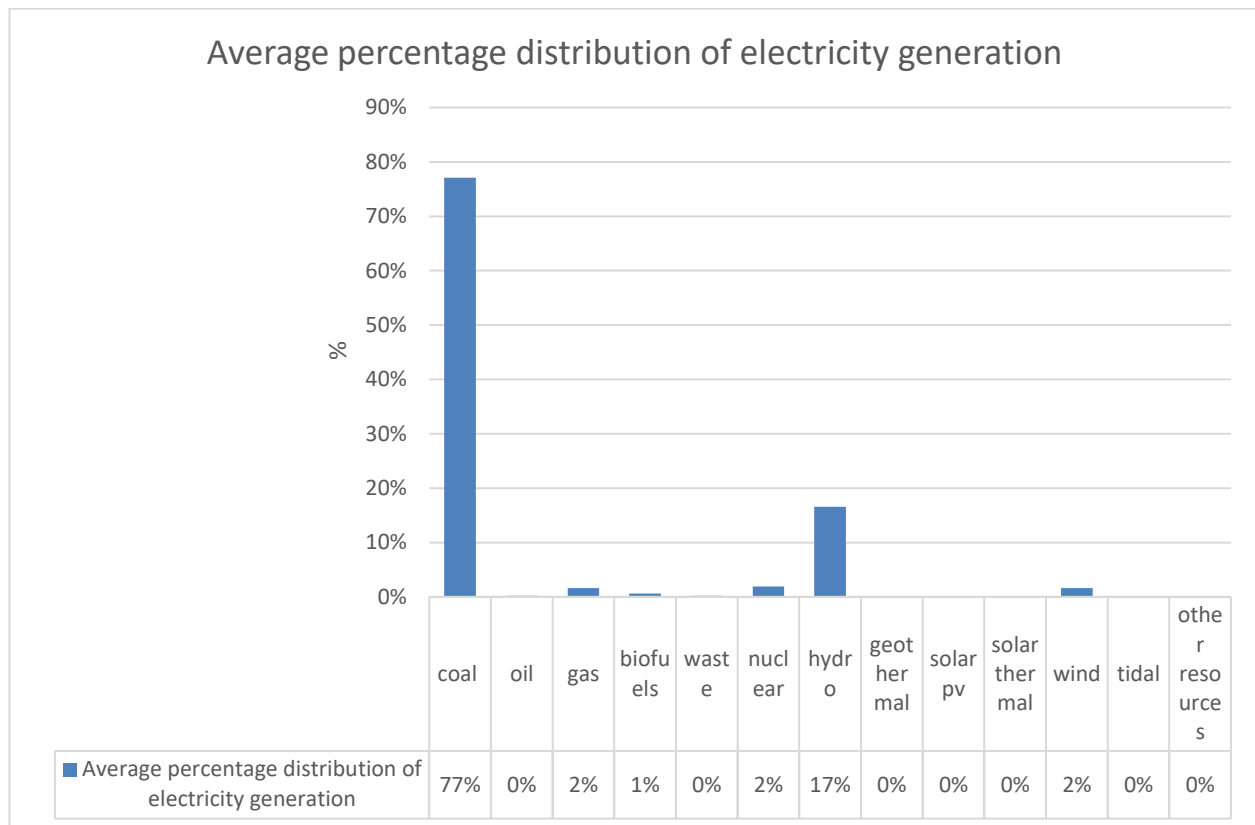

Moreover, the table below is interolated from IEA and finds the average energy consumption for heat and electricity:

	Electricity Consumption						avg	Heat Consumption					
	2013	2012	2011	2010	2009			2013	2012	2011	2010	2009	
Domestic Supply	5,436,000	4,983,259	4,715,761	4,194,479	3,730,581	4,612,016	3,646,157	3,463,385	3,221,153	2,978,212	2,667,479	3,195,277	
total consumption	5,435,902	4,982,733	4,702,817	4,194,273	3,730,518	4,609,249	3,646,157	3,463,385	3,221,153	2,978,212	2,667,479	3,195,277	
energy industry own use	622,165	565,022	570,207	486,705	439,153	536,650	441,020	416,964	410,665	395,282	347,568	402,300	
losses	314,071	289,616	270,070	256,824	225,822	271,281	42,140	36,562	35,482	34,092	31,803	36,016	
final consumption	4,499,666	4,128,095	3,862,540	3,450,744	3,065,543	3,801,318	3,162,997	3,009,859	2,775,006	2,548,838	2,288,108	2,756,962	
industry	3,017,543	2,793,867	2,654,345	2,362,872	2,037,010	2,573,127	2,181,842	2,072,831	1,928,754	1,742,711	1,497,160	1,884,660	
transport	56,925	51,981	46,340	39,789	32,590	45,525	-	-	-	-	-	-	
residential	698,916	621,896	562,006	512,463	487,216	576,499	814,720	776,075	700,439	674,102	670,002	727,068	

commercial and public services	268,273	244,261	220,525	191,964	168,441	218,693	74,490	71,192	63,598	55,853	49,286	62,884
agriculture and forestry	102,687	101,257	101,290	97,649	93,990	99,375	1,186	1,134	907	910	827	993
fishing	-	-	-	-	-	-	-	-	-	-	-	-
other non specified	355,322	314,833	278,034	246,007	246,296	288,098	90,759	88,627	81,308	75,262	70,833	81,358

The data is simplified into percentage distribution. For our main focus, being residential energy consumption, we see that over period of 5 years it averages to be 13% in the whole of China while heat doubles that result to be around 23%.

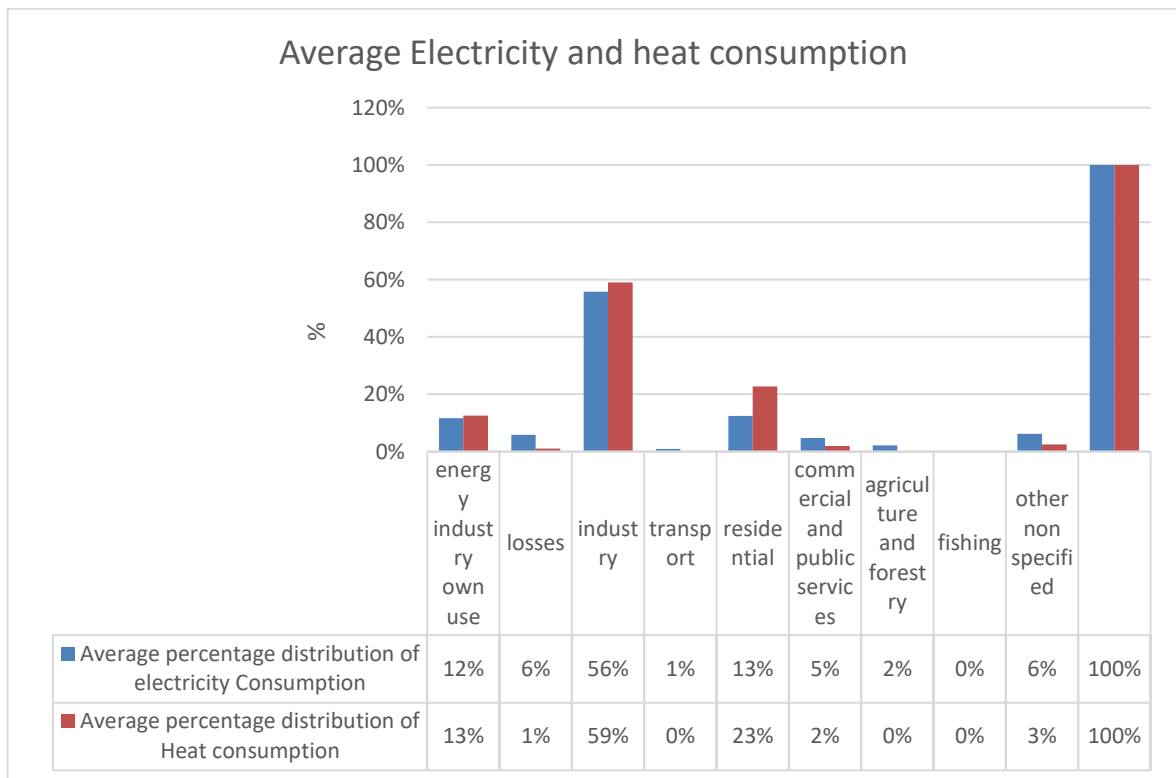

Finally, the figure below provides the current energy production levels, which also shows the energy mix and potential level of CO<sub>2</sub> emissions (Source: IEA, 2015).

## Energy Snapshot of the Week

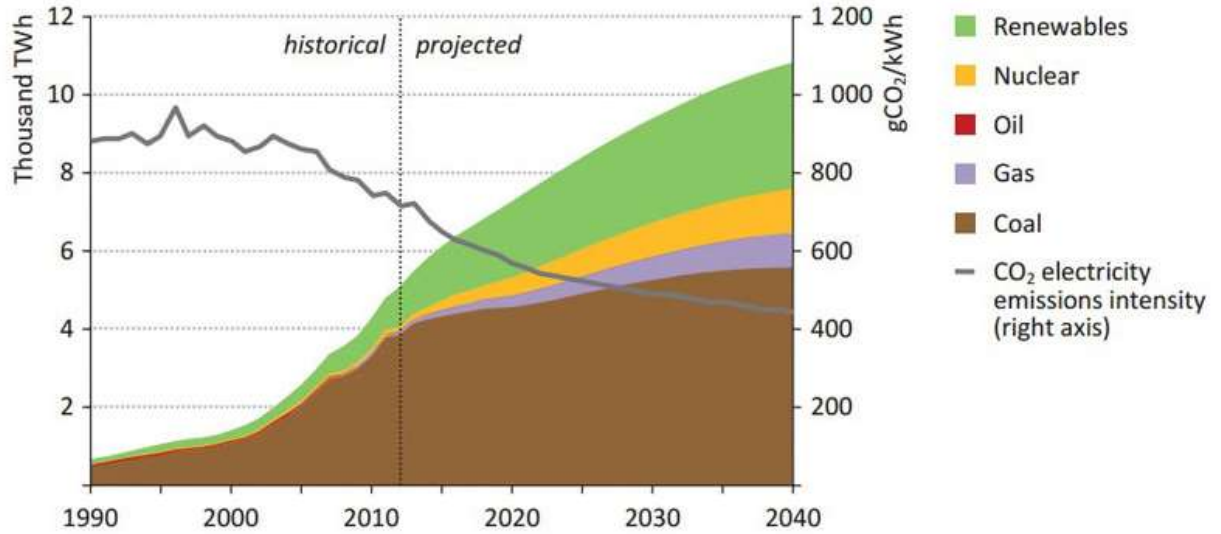

In total, we have the energy mix in terms of energy generation, energy projection according to IEA till 2050 for China, and we know the percentage and amount of energy consumed by residential buildings as well as other sectors. Therefore, we can estimate the predicted emissions from the energy generation.

### 4. Materials and embodied energy/carbon in low income houses.

In 12 years (between 2000 and 2012), China has built twice as many new homes as there are today in the entire United Kingdom. China consumes half of global steel usage in 2015 and is expected to continue the use of concrete and steel in the housing sector. Diagram below represented the number of new accommodation units built on annual basis.

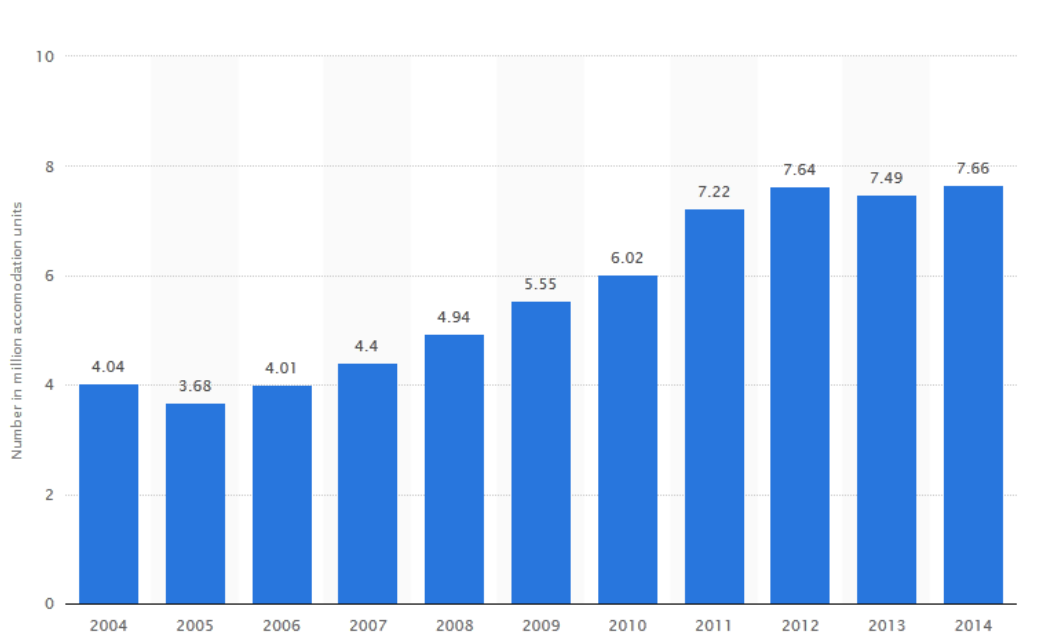

Source: Statista, 2016.

There are significant differences in material use between rural and urban housing units. Also there are some differences in various regions. In most cases, bricks are not used in construction of houses anymore. Most contemporary houses, particularly the low income models, are built with in-situ concrete as the main material. For medium to high-rise housing units, there is more steel use for the structural use.

For low to medium income houses, the thickness of concrete external walls range from 200mm to 300mm and internal partitions are mostly below 200mm (often 150mm to 200mm). The cladding is normally tiles or slabs that are often representation of brick pattern. Concrete blocks are often used in case of no in-situ construction.

In the context of China, current methodologies in research of embodied materials and embodied energy include the followings:

#### ***Life Cycle Assessment (LCA)***

- Quantifying environmental impacts of products
- Standards: ISO 14040s → GB 24040 (China)

#### ***Type III environmental declaration***

- Also, Environmental Production Declaration (EPD)
- Verified LCA reports of products;
- Standards: ISO 14025 → GB 24025 (China), ISO 21930s, ...

#### ***Carbon footprint (CF)***

- Verified life cycle greenhouse gas emissions of products
- Standards: PAS2050, WRI GHG protocols, ISO 14067 and etc.

The idea of the carbon footprint (CF) is an indicator of the environmental effects of energy use, which recently has become a widely used term and concept in the public debate on appropriate responses to mitigate the threat of global climate change (Wiedmann and Minx 2008). Currently, there is no consensus on how to measure or quantify a carbon footprint (Wiedmann and Minx 2008, Matthews et al. 2008).

Chinese LCA Database (also known as CLCA)

The International Energy Agency (IEA 2007:307) projects that 800 million m<sup>2</sup> of new urban residential floor space will be built in China annually through to 2030. This is largely attributable to the steady urbanization, growth of household income, growth of the service sector (Taylor et al 2001) and decreasing average household size (IEA 2007:306). In 2009, LCA award was given to China by UNEP/SETAC.



CLCD core model, May, 2009.

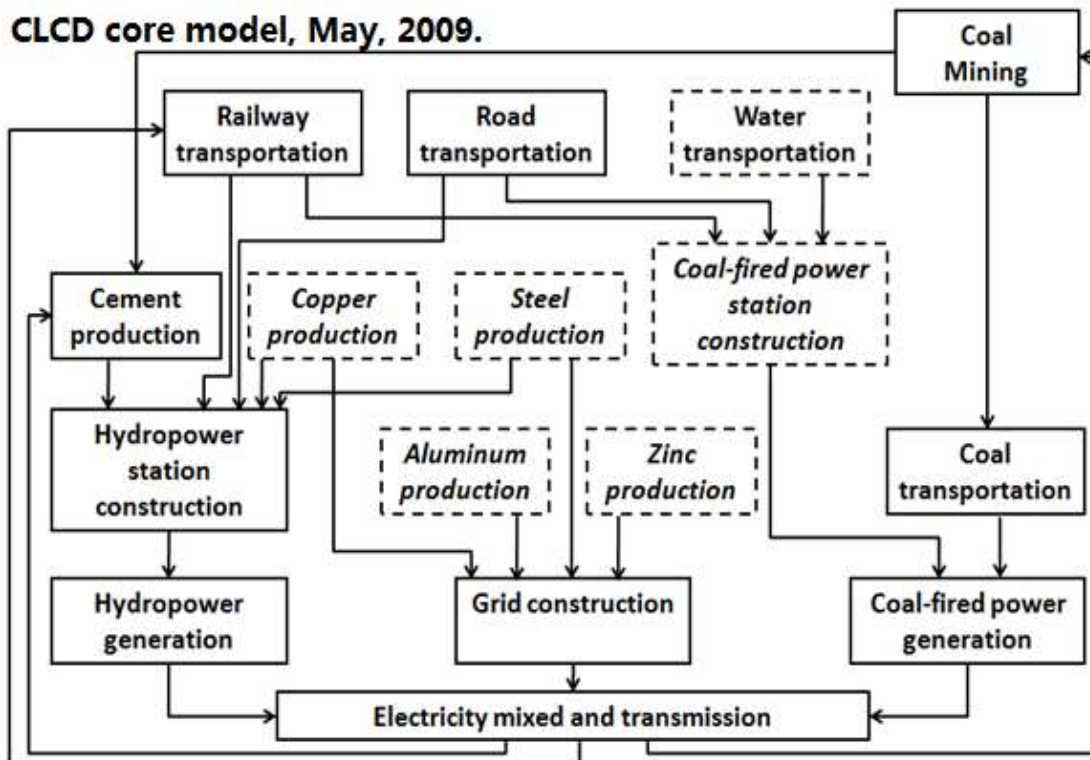

Figure 3. Chinese LCA core model; initial model in 2009.

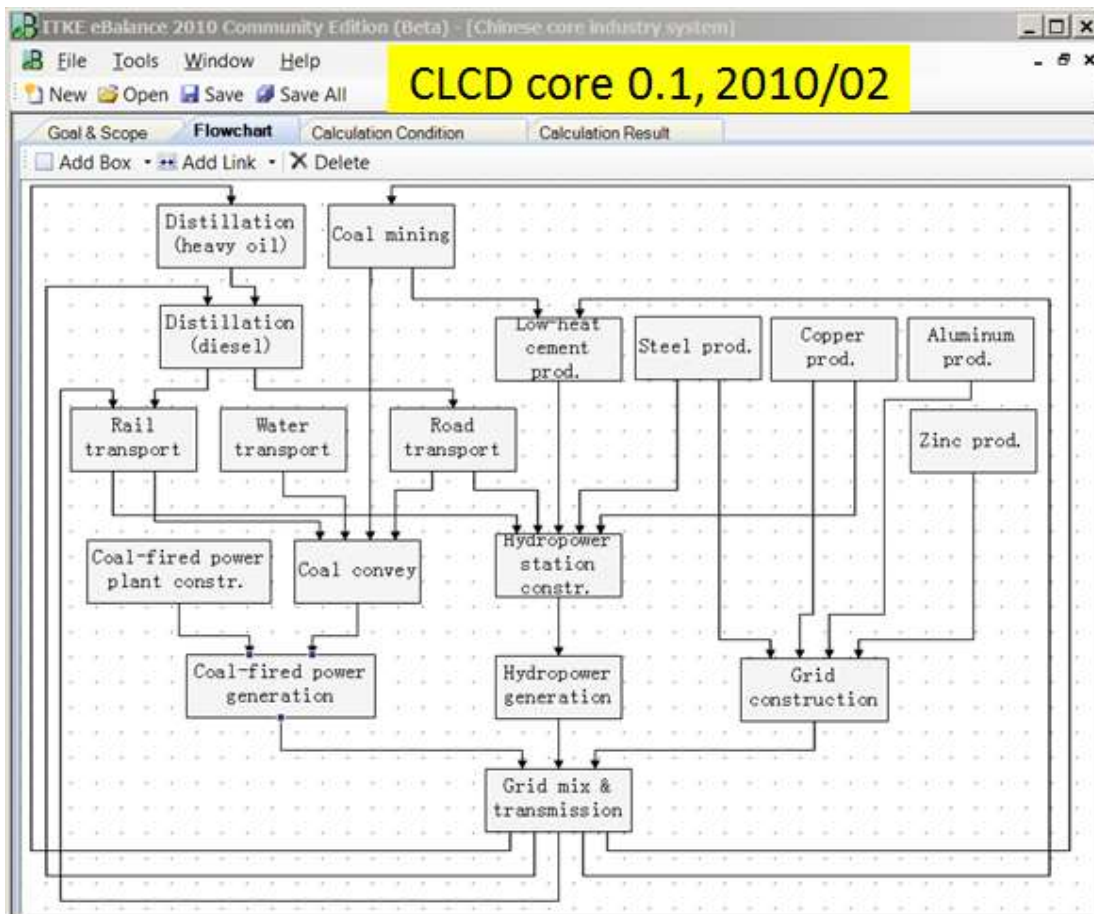

Figure 4. CLCA core model; developed model in 2010.

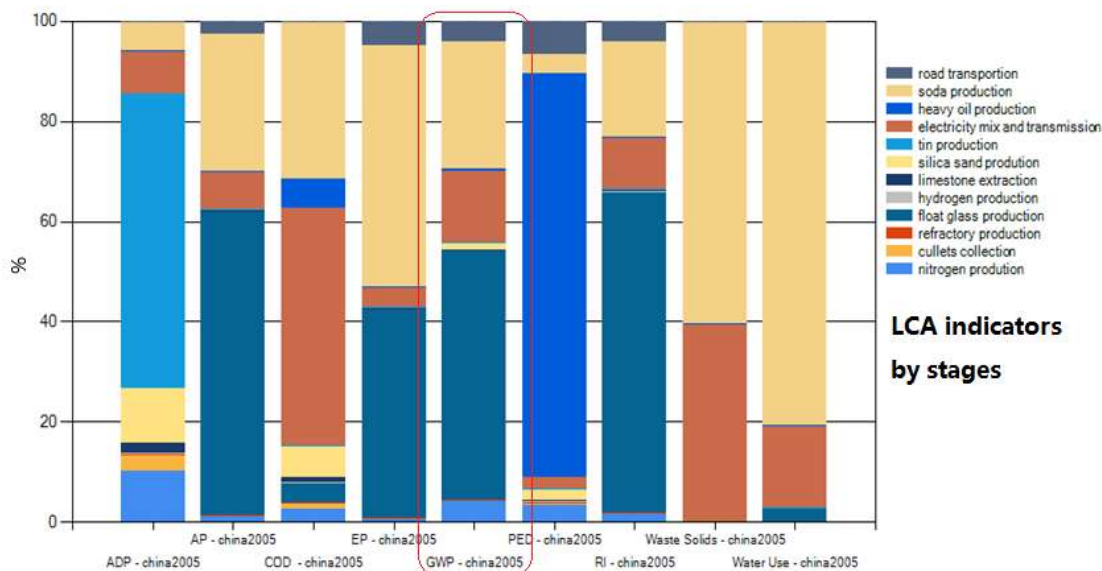

Figure 5. China's LCA indicators by stages.

### ***China's Database in eBalance***

China's database in eBalance, conveyed with CLCD, ELCD and Ecoinvent, was first released on Sept. 19, 2010. This database includes the followings:

- ☒- Energy carriers: electricity, fossil fuels;
- ☒- Transport: road, railway, river canals;
- ☒- Metals: iron and steel, aluminum, copper, lead, zinc;
- ☒- Chemicals: H<sub>2</sub>SO<sub>4</sub>, NaCO<sub>3</sub>;
- ☒- Building materials: cement, glass, aluminum-plastic board, ceramics.

### ***National Standards for Verification***

As part of China's national standards for verification, we can witness significant progress from appliances standard verification to verification processes for lifecycle of buildings and low-carbon design. A set of national standard documents are already in place as part of China's framework and principles.

### ***5. Trends in operational energy use and embodied carbon footprint***

China has recently released their 13<sup>th</sup> –year plan, in which they include key targets by 2020. This includes key initiatives of: 15% energy reduction, 18% CO<sub>2</sub> reduction and 4% increase in urbanisation. Buildings, including appliances use, consume more than 28% of China's overall energy consumption. This is still below the world average of 34% (2014 figures). Yet, with the expected increase of consumption in forthcoming years, the overall consumption from the building sector will even become more significant than it is today.

The national projection of new built housing units is expected to remain at a similar rate of approximately seven to eight million units a year. However there are no valid sources that can indicate the total household energy consumption (both embodied and operational).

## **6. Brief summary of low income house design challenges, findings and proposals**

As identified by Xu (1993, p. 41), China's housing sector, both in the urban and rural areas, have their own problems of development. For the rural the problems of poverty are coupled with issues of population decline, ageing society and deprived living conditions. For the more prosperous areas, rural housing is developed steadily; but for the more deprived ones, rural housing lacks adequate maintenance and development plans.

Our ELITH-China research focuses on urban housing while addressing some of the issues on rural housing. The main challenges for each are demonstrated below:

### ***Rural Housing – Challenges and Findings***

Rural housing is one of the most crucial but yet the least studied areas of housing development sector in China. Rural housing is often regarded as the traditional one or two storey dwelling that is often built from locally-resourced materials. However, in recent years this traditional trend of rural housing is changing rapidly. The transitions are becoming very apparent, and yet significant, that the national reports (such as the New Urbanisation Plan, March 2014) are considering different possibilities of approaching the rural housing development strategies. The critical view is on the transition of rural housing towards peri-urban model of housing or even urban housing, where medium-rise housing is common.

The main challenges are:

- Rapid transition of material use from locally resourced to new modern materials - this also requires new materials and labour coming from cities;
- The increase in number of floors from traditional 1 or 2 floors to mid-rise;
- Lack of individual maintenance for housing units – in some cases, only the local government can propose for maintenances;
- Traditional use of energy (such as coal, wood, etc.), mainly for cooking and heating;
- Gradual increase of air conditioning units in compare to natural ventilation use and electric fans;
- Lack of national policies.

### ***Urban Housing – Challenges and Findings***

China's urban housing is a major part of Chinese building sector. It is a rapidly growing market, mainly in hands of estate developers. Our studies point out transitions from town housing to high-rise housing that are also seen in the context of South-East Asian countries. Most of new housing developments in the past one decade are built in gated (or enclosed) compounds. This pattern is expected to change as the Chinese central government has recently announced a new policy to opening up the gated communities (launched February 2016). In the past two years, ELITH-China research has been arguing against gated communities as a bottleneck to sustainable urban development.

The main challenges are:

- The increasing density and FAR for urban housing compounds;
- The gated pattern which brings in many social and environmental concerns;
- The rapid increase of air conditioning units in recent years (in some city statistics, the numbers are doubled in less than six years);
- The increasing underground infrastructure which has impact on the overall site impact of such housing development;
- Poor quality green infrastructure which reflects on the previous point;
- The increasing car-user friendly pattern that also indicates rapid increase of car ownership in most Chinese cities;
- Large scale masterplanning-level housing projects in Chinese cities;
- The increase use of glazing in facades and decrease of balconies;
- Short-lived solutions due to current leasehold conditions (i.e. 70 years).

Solutions to above are proposed in Document # 02.