

Rationale for Simplifying the Strength Formulae for the Design of Multi-row Bolted Connections Failing in Net Tension

J. Toby Mottram (Prof.)
Civil Research Group
School of Engineering,
University of Warwick, Coventry
CV4 7AL, UK

ABSTRACT

Hart-Smith [1] developed a set of closed form strength formulae for a semi-empirical approach to determine the net tension strength of multi-row bolted connections with composite materials. Mottram [2] showed that, for a pultruded fibre reinforced polymer material, the approach to be reliable (and conservative) for the configuration comprising two rows with a single bolt per row. This led to the formulae being developed into clauses in an American pre-standard for *Load and Resistance Factor Design (LRFD) of Pultruded Fiber-Reinforced Polymer (FRP) Structures* [3]. Because the expressions in the Hart-Smith formulae are not simple, the message coming from the practitioners, on the ASCE/SEI Fiber Composites And Polymers Standards committee (FCAPS) tasked with developing the pre-standard [3] into a standard, is that they would not use them when designing bolted connections. Taking stock of the specified geometries, bolt details and design parameters permitted by the pre-standard [3] the author conducted an analytical parametric study using the Hart-Smith formulae with the aim of establishing simplified forms that could be routinely used in the design office. Presented in this paper is the provenance to this code-specific work when the connection has more than a single row of bolts. A presentation is given to what has been lost, in terms of calculated net tension strength, by providing the simplified strength formula in the mandatory part to the standard. To enable the designer to be able to take full advantage of the Hart-Smith design approach [1, 2], the 'complicated' formulae and their accompanying mandatory-style text are to be found in an appendix with the standard's commentary [3].

INTRODUCTION

The Pultrusion Industry Council (PIC) in the American Manufacturers Composites Association (AMCA) has been the driving force behind a six year project to establish a design standard for *Load and Resistance Factor Design (LRFD) of Pultruded Fiber-Reinforced Polymer (FRP) Structures*. A pre-standard version was finalized in November 2010 [3], and an ANSI standard process has been progressing since with the goal of publishing the new (ASCE) standard in 2013 or 2014. The standard has eight chapters and comprises both mandatory and commentary parts. The commentary part provides information on the design philosophy and background information towards the choice of strength formulae and the test results used in the reliability analysis to establish the (various) resistance factors. Mandatory clauses permit connections between FRP and FRP and between FRP and metallic components to be by ('conventional' steel) bolting. Chapter 8 is for the design of bolted connections and the determination of their strength by way of (simple) strength formulae for a number of known distinct modes of failure [3].

Table 1 reports minimum geometry dimensions in terms of the multiples of bolt diameter (d) that are permitted in multi-row bolted connection configurations with the number of bolts limited to three for both rows and columns of bolts.

The essence of what can be the depth and breadth of the information given in the commentary is presented next by way of focusing on the distinct mode of failure known as net tension. Consider a double-lap shear joint (there is no moment due to load eccentricity) with loading in the plane of the plates. The force resisted by this bearing-type connection creates a direct stress distribution across the effective width (w) of the connection component. When this force

acts toward the end there is a tensile stress distribution across the net-section. This stress is not constant and has its highest value at the perimeter of a hole [3, 4]. To develop closed-form equations which calculate a connection's strength for the net tension failure mode, Hart-Smith [1] uses the closed-form equations for the stress concentration factor (k_{te}) when the material is isotropic. He postulated a linear relationship between the required orthotropic material stress concentration factor (k_{tc}), for which there was no closed form solution, and the known isotropic stress concentration factor (k_{te}). In terms of a coefficient C (which Hart-Smith calls a correlation coefficient [1]) the semi-empirical relationship assumed is

$$\begin{aligned} k_{tc} - 1 &= C(k_{te} - 1) && \text{with} \\ k_{tc} &= F_t t (w - d_n) / P && \text{where} \end{aligned} \quad (1)$$

F_t = Tensile strength of material associated with the net tension plane of failure (depends of FRP material orientation)

w = Width of material, having constant thickness t (width and effective width are the same)

d_n = Diameter of hole, which is diameter of bolt (d) plus hole clearance (in Hart-Smith's development [1] the two diameters are identical)

P = Tension load when the bolted connection fails due to the net tension mode

k_{te} = Isotropic stress concentration factor for the same joint geometry.

Table 1. Minimum requirements for bolted connection geometries for multi-row configurations without bolt stagger.

Notation	Definition	Minimum required spacing (or distance in terms of nominal bolt diameters) Tension or compression load
$e_{1,min}$	End distance	$2d$
$e_{2,min}$	Edge distance	$1.5d$
s_{min}	Pitch spacing	$4d$
g_{min}	Gage spacing	$4d$

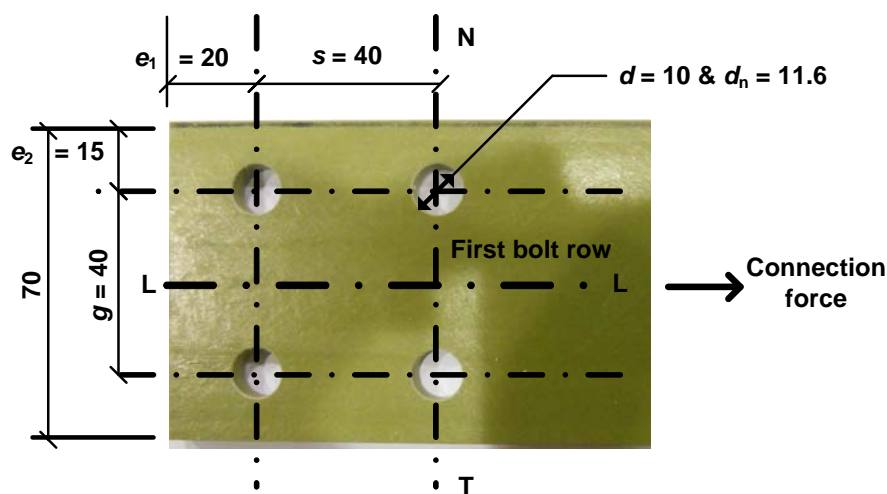

Figure 1. Connection component (plate of constant thickness) with minimum geometry for the situation when the bolting is of M10 size.

To determine the value of the coefficient C in Equation (1), the gradient is found for the plot of $k_{tc} - 1$ against $k_{te} - 1$, using physical test results from single bolted connections with a range of double-lap shear connection geometries that fail in net tension. With the Hart-Smith modelling approach [1] if C is 1.0 the material response is perfectly brittle and if C is zero the material is perfectly plastic in its behaviour across the net section under bearing load.

The commentary continues by developing the strength formulae that are specific to the situation when the bolted connection has a single row of bolts, the number of bolts permitted in the row is from one to three. It is noteworthy that the single row configuration gives the highest joint strength efficiency [1]. This efficiency would be 100% if the connection strength is equal to the gross tensile strength at the net tension plane ($F_t tw$). It is always lower because of the loss material area and the presence of stress concentrations on the net tension plane. In this presentation we shall focus on information that is specific to the situation when there are two or three rows of bolts; the maximum number of bolts per row (n_{max}) is three.

The formulae for the connection strength $R_{nt,f}$ for net tension failure at the first bolt row have been simplified in the mandatory part for ease of design strength calculation. To give the simplified formulae provenance the process leading to their form is the new contribution developed in this paper. Should the designer want to take advantage of the additional available strength, which can be considerable (say doubled), the commentary part in the standard has an appendix giving the full set of formulae, with mandatory-type text, to directly exploit the original Hart-Smith approach [1]. The appendix at the end in this paper reproduces these guidelines for the case when the connection force acts at an angle of orientation of between 0° and 5° to the Longitudinal (see Figure 1) direction of pultrusion.

When two or more bolt rows are positioned with pitch spacing (s) the connection force, acting in the direction of pitch, may not be distributed uniformly amongst the bolt rows [1]. The first row of bolts, or bolt (if each row has a single bolt), might carry, in bearing, a proportionally higher share of the connection force. The bolting at the first row, which is labeled NT in Figure 1, is the furthest row away from the unloaded free-end of the connection component. This row of bolting is found to experience much higher stress concentrations than the bolting in the nearer row(s). The bearing-induced net tension stress concentration (the stress distribution for the single-bolt connection) combines with the net tension stress concentration created by the presence of the tension by-pass load for the unfilled hole. The by-pass load provides the connection force carried by the subsequent bolt rows in bolt bearing (assuming none of the load is transferred across the contacting surfaces by frictional force).

While multi-row bolted connections can be used to decrease the bearing stress, and end distance (e_1), they encourage, rather than inhibit, the occurrence of the potentially more catastrophic (what is referred to as 'brittle') net tension failure mode. To this problem must be added the caveat that, since FRPs are brittle materials, each hole in a multi-row bolted connection must be a nearly perfect fit to actually achieve a reduction in bearing stress rather than having all or much of the load taken by the first bolt to bottom out in its loose hole.

The design guidelines given in this paper's appendix is based on the recommendations made by Mottram [2], whose work followed the semi-empirical approach of Hart-Smith [1]. The approach assumes that on load application all the identical bolts are in contact, and in the direction of the connection force, with the perimeter of their clearance holes. When there are two or more bolt rows, failure is more likely to be in net tension because there may be a higher proportion of the connection force taken at the first row and because of the interaction of the two net tension plane stress concentration factors caused by bolt bearing and by-pass loads [2]. That part of the connection force at the first row not resisted by bearing has to flow around the bolt hole(s) to be taken in bearing by the bolting in rows two, etc. This force is the by-pass load component to the connection force. Table A1 gives the proportions of the connection force that are to be taken for the bearing and by-pass load components. The bolt force distributions in the table are taken from Clarke [5]. These values are for connections with both double-lap (and single-lap according to [5]) configurations. They were obtained from static finite element analysis using a modeling methodology that assumed the identical bolts are just touching the perimeter of same sized holes (i.e. no hole clearance) at the onset of tension loading. It must be recognized that Table A1 values have no provenance as there is no publication giving us details on the specific finite element work. For the case of having three bolt-rows and FRP components they are very similar to the predictions using the analytical method from McCarthy *et al.* [6]. The load distribution between bolt rows will clearly be affected by the precise placement of the bolting in holes with clearance. The redistribution of loading that occurs with initial clearance between bolt and hole perimeters can be investigated theoretically using the McCarthy *et al.* analysis method.

The set of strength formulae in the appendix (Bolted Connections with Two or Three Rows of Bolts – Full Formulae) are based on a linear interaction assumption, such that the bearing formulae for single row connections (having one to three bolts) are now combined with a second term that represents the effect of the additional tensile stress concentration factor from the by-pass force at the (NT) net tension failure plane. If we ignore the existence of the bearing load, the by-pass load is seen to be associated with the open-hole tensile strength of the FRP material. By using the same semi-empirical approach that is summarized through Equation (1) for the 'filled' hole situation (i.e. the bolt is present), the coefficient C_{op} for the open-hole situation can be established. As reported in the appendix below a conservative value of 0.5 for $C_{op,L}$ was obtained for pultruded FRP material after evaluating, in [2], the open-hole tension strength test results from Turvey and Wang [7]. Subscripts 'L' in notation $C_{op,L}$ is for the connection force coincident with the material's Longitudinal (or 0°) direction [3].

The filled hole coefficient C_L in the appendix below is for the situation when the connection has a single bolt [2]. It is noted that C_L is 0.50 (a conservative value) for pultruded shapes and is lower, at 0.40, for pultruded (flat sheet) plates. Coefficients appropriate to other FRP material may be determined by testing in accordance with Section 2.3.2 in the mandatory part to the standard and by adopting the guidance in Mottram [2].

Figure 2 presents ratios of the experimental strengths ($R_{nf,f,exp}$) to those predicted ($R_{nf,f,theory}$) using information from [2] and [3] and Equations (A1a) to (A3b) in the appendix for net tension failure in the Longitudinal direction. Note that because the values for C_L and $C_{L,op}$ are those introduced above, the ratios in Figure 2 are higher than in Figure 5 of [2], when $C_L = 0.33$ and $C_{L,op} = 0.37$. The resistance factor for this presentation is set to 1.0. The connection configuration in the double-lap shear tests has two bolts aligned parallel to the direction of the connection force and separated by a pitch spacing (s) of $5d$. The end (e_1) and side (e_2) distances were variables in the test series. Material thickness (t) across the full width (w) is constant. To construct Figure 2 requires the multi-row strength results (with test numbers 0A2, 0A3, etc.) from Hassan *et al.* [8] and the mechanical properties of the ½ in. (12.7 mm) thick pultruded FRP material from Rosner and Rizkalla [9]. The experimental test procedure and the pultruded (flat sheet) plate materials were the same as those employed by Rosner and Rizkalla [9]. Hassan *et al.* [10] misinterpreted how to apply the Hart-Smith approach as they neglected to account for the stress concentrations due to both bearing and by-pass loads; the latter stress concentration is missing. As a result, their analytical contribution towards the calculation of net tension strengths cannot be reliably used as it is not rigorous to the original approach detailed in reference [1]. Because Hassan *et al.* [10] did not involve the by-pass load in their work, no open-hole strength data is available for the ½ in. (12.7 mm) thick plate material used in their bolted connection tests.

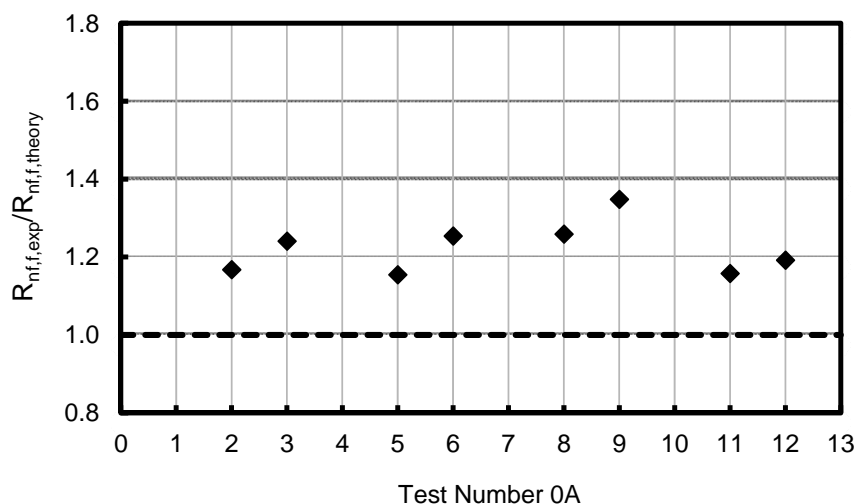

Figure 2. Ratios of experimental strength with predict net tension strength for multi-row bolted connections using the longitudinal material test results from Hassan *et al.* [9] and Rosner and Rizkalla [10] and the design formulae of Equations (A1a) to (A3b) and information from [2].

For all the eight test results in Figure 2 it is seen that their (experimental strength/Equation (A1a)) ratios are well in excess of 1.0, showing that, for this multi-row connection configuration and set of test results, the determination of net tension strength is considered to be conservative (and prior to the resistance factor introduced), when applying the guidelines reproduced in the appendix below.

The line drawings in Figure 3 provide illustrations to show how the distances e_3 and e_4 , in the strength formulae Equations (A1a) to (A3b) are to be defined at the plane (NT in Figure 1) for the first row of bolts. They are not distances between pairs of hole centres. The Longitudinal (0°) direction is defined in Figures 3(a) to 3(f). In Figures 3(a) to 3(c) the connection force is directed normal to the free edge of the connection, which is at a distance e_1 from the centre of the hole nearest this free edge (see Figure 1). In design the direction of the connection force is now acting between 0° and 5° to the Longitudinal direction. Three different geometric cases are illustrated, with Figure 3(a) for a flat plate (of constant thickness t) of width $w = 2e_2$, Figure 3(b) for the case where one unloaded edge (the situation can be for both unloaded edges) has a perpendicular (plate) element to the plane of the bolted connection and the width of the connected component is $w = 2e_2$. The material thickness in the connection is no longer constant. Figure 3(c) is either for a flat plate or a component with one or two perpendicular elements (not shown in illustration), giving a modeling width $w \gg 2e_2$. Although not required for the parametric study in this paper the same three geometric cases are shown, for completeness, in Figures 3(d) to 3(f) for the situation when the connection force is taken to be acting perpendicular to that for the three cases shown in Figure 3(a) to 3(c). For design the direction of the connection force is now acting between 5° and 90° to the longitudinal direction and the Transverse orientation provisions must be applied (they are not given in the appendix with this paper). Note that when there are two or three bolts in the first row across the width of the connection the only change from that shown in Figures 3(a) to 3(f) is that distances e_3 and e_4 are, respectively, defined from the centre of the two outermost bolts.

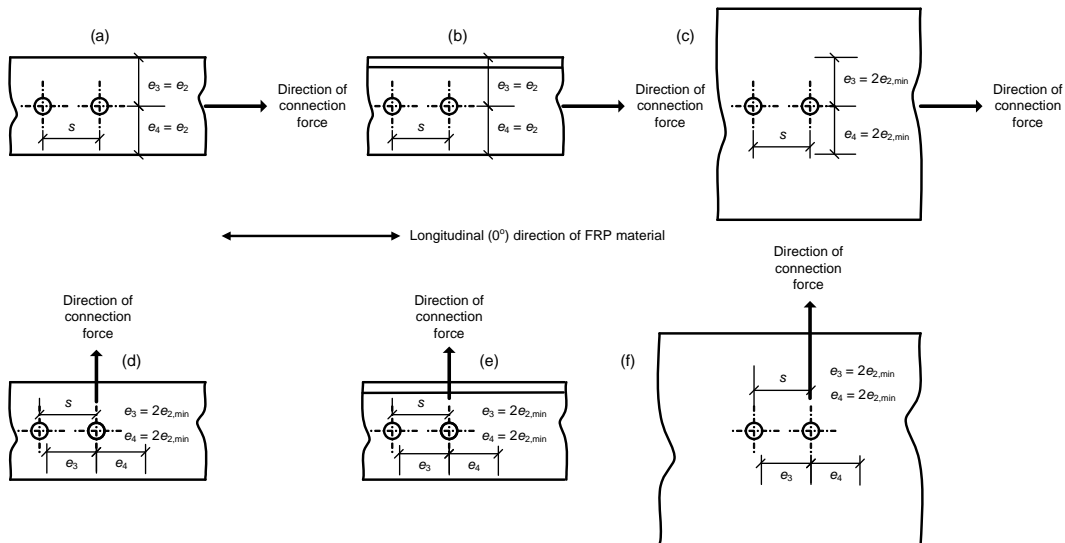

Figure 3. Illustrations of different connection configurations for how distances e_3 and e_4 are to be defined when the bolted connection has two or three rows of bolts (reproduced from [3]).

SIMPLIFYING THE HART-SMITH FORMULAE FOR BOLTED CONNECTION STRENGTH

It is observed that the governing Equation (A1a) can be written as:

$$R_{nt,t} = rf wt F_L^t \quad (2)$$

In Equation (2) notation rf is for the reduction factor (no units) to the gross tensile strength of the connecting component without any bolt holes (for the gross cross-sectional area). This

reduction factor is given by the (complex) expression in Equation (3) with $K_{nt,L}$ and $K_{op,L}$ defined by Equations (A2a) and (A3a) or (A2b) and (A3b), respectively. Expressions to calculate $K_{nt,L}$, for the net tension stress concentration factor in Longitudinal direction for a filled hole, and $K_{op,L}$, for the net tension stress concentration factor in Longitudinal direction for an unfilled hole, are given in the appendix.

$$rf = \left[\left(K_{nt,L} L_{br} \left(\frac{w}{nd} \right) \right) + \left(\frac{K_{op,L} (1 - L_{br})}{\left(1 - n \left(\frac{d_n}{w} \right) \right)} \right) \right]^{-1} \quad (3)$$

To simplify the calculations that the designer must carry out to check the net tension strengths of the multi-row bolted connections we must establish the range of design parameters that are permitted by the standard and that shall influence the magnitude of the reduction factor, given by Equation (3). By establishing the upper and lower bounds to rf an analytical parametric study is needed. It will be shown, in what follows next, that by taking the 'lowest' rf for practical connection geometries the simplified form to Equation (1) can be

$$R_{nt,t} = 0.2wt F_L^t. \quad (4)$$

The justification for not specifying rf with more than one decimal place is so the formulae can be easily remembered, and to, hopefully, emphasize that it is a pragmatic (designers') simplification to the rigorous design approach. It is noted that Equation (3) is neither dependent on the (assumed constant) thickness of the material (t) nor on the material's tensile strength, which is specified by its orientation to the connection force. The standard permits steel bolting of diameters 9.53 mm (3/8 in.) to 25.4 mm (1 in.). Table 1 can be used to establish the minimum values for the geometric ratios for w/d and w/d_n , and it is important to calculate the lowest rf value with $d_n \neq d$. In American practice the nominal clearance hole size is constant at 1.6 mm (1/16 in.); this ensures that $d_n = d + 1.6$ mm, if drilling/reaming tolerance is neglected. The maximum effective (or actual) width w depends on the number of bolts (n) across the row, the maximum side distance e_2 (or dimensions e_3 and e_4), and the maximum gage spacing distance g . The maximum number of bolts in both a row and a column (perpendicular to a row) of bolts is three. The upper and lower bound values for the proportion of the connection force taken in bearing at the first bolt row (L_{br}) are defined in Table A1. For pultruded material values for the coefficient for bearing load in the longitudinal (C_L) and for the coefficient for by-pass load in the longitudinal direction of pultruded material ($C_{op,L}$) are those specified in the appendix below.

To find the range of the values for the reduction factor (rf) an analytical parameter study was required using Equation (3) with the permitted range of design variables. Illustrated in Figures 4 and 5 are flat plate components for the specific connection configurations when $n = 1$ and $n = 2$, respectively. Drawn to scale these figures are used to define, in terms of d , the minimum geometries for end distance (e_1), side distance (e_2), pitch spacing (s) and, in Figure 5 only, gage spacing (g). For these two connections it may be assumed that the component is a plate of constant thickness (t) across the width, the effective width is therefore also the actual width.

Results to establish the range to rf will be given to two significant figures. We need to realise what is the lowest value of rf is, to generate the simplified strength formula, which is Equation (4) above. Lets first consider the configuration in Figure 4, and take $e_1 = 2d$, $C_L = 0.5$ (for structural shapes), $C_{op,L} = 0.5$ and $L_{br} = 0.5$ (for FRP on FRP). Note that if C_L is taken to be 0.4 for pultruded flat sheet material rf will increase; this observation means that C_L for structural shapes is the worse case. For the smallest bolt diameter $d = 9.53$ mm (or 10 mm) Equation (3) gives $rf = 0.33$ when $w = 2e_{2,min} = 3d$. Because rf is a function of the w/d ratio, it is not surprisingly that rf is insensitive to the bolt diameter, and so when $d = 25.4$ mm (or 25 mm) rf is 0.34. The difference of 0.01 is because the clearance hole size (constant at 1.6 mm) is not proportionally to d ; all other connection dimensions (Table 1) are proportional to the bolt diameter. The value of rf decreases as the (effective or actual) width ($w = 2e_2$) increases. The minimum width for the configuration in Figure 4 is $3d$. On taking $d = 10$ (or 25 mm) and doubling w to $6d$ the new $rf = 0.29$ (or 0.29). By doubling w again to $12d$, we have that $rf = 0.19$ (or 0.19).

This rf would be unacceptable because it is below the factor 0.2 in Equation (4). It is however unlikely in practice that the width would be as high as $12d$ for this connection configuration and this is the justification to specify a reduction factor of 0.2. It is observed that on increasing (within practical bounds) either the end distance (e_1) or the spacing (s) has little or no influence on the value of rf .

Given that the strength Equation (4) specifies that the reduction factor is to be 0.2 in the standard, this imposes a limit on the size of the effective width. In the case of the configuration in Figure 4 this limit is defined by $w/d = 10$ (if the ratio is to be an integer). With this effective width it is found that $rf = 0.21$ by Equation (3).

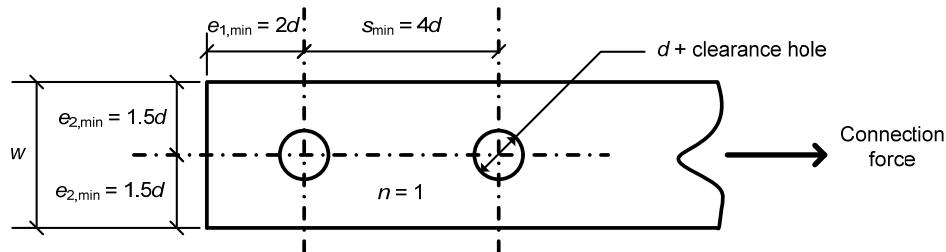

Figure 4. Multi-row bolted joint with minimum geometric ratios and single bolt ($n = 1$) across the effective width w .

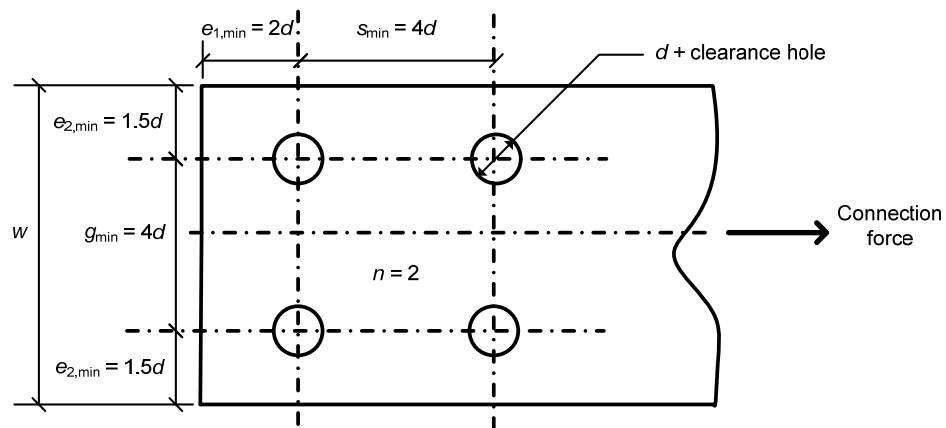

Figure 5. Multi-row bolted joint with minimum geometric ratios and two bolts ($n = 2$) across the effective width w .

As Table A1 shows the proportion of the connection force taken in bearing at the first bolt row depends on the materials being joined together. If one of the components in the connection is of steel, L_{br} for the FRP component is 0.6. rf is now found to be 0.32 ($w/d = 3$), 0.27 ($w/d = 6$) and 0.17 ($w/d = 12$). Although these reduction factors are lower than for the FRP connection, its value remains > 0.2 at the (practical) width limit of $w/d = 10$.

Although not illustrated in Figure 4 another multi-row bolted connection has a single column with three rows of bolts. The only change required to establish what rf is, is to change L_{br} from 0.5 to 0.4 (FRP on FRP). For this multi-row case the value of rf is always (slightly) higher than for the situation with two bolts and $L_{br} = 0.5$. We do not need to consider this less severe case further.

The geometry in Figure 5 has another connection dimension (g) to change as it needs to account for two bolts (maximum is three) across the width of the FRP component, which is taken to be a plate of constant thickness. For this parametric study we let $e_1 = 2d$, $s = 4d$, $C_L = 0.5$, $C_{op,L} = 0.5$ and $L_{br} = 0.5$ (for FRP on FRP). The effective (and actual) width is given by $w = 2e_2 + g$ and so its range is dependent on changes to two connection dimensions. Table 1 presents five reduction factors obtained using different combinations of the geometric ratios e_2/d and g/d for w . The rf in the third row gives us a limit on g/d , which ensures the reduction factor of 0.2 in Equation (4) remains valid. The same non-sensitivity in rf to connection dimensions d , e_1 and s can be established.

One positive finding from the reduction factors presented in Table 2 is that the lowest rf will be obtained when side distance $e_2 = e_{2,\min} = 1.5d$. Its importance becomes apparent when the effective width is for the (common) situation in practice where the connection component is not of constant thickness and w requires e_3 and e_4 to be established as per the 'rules' given in the appendix, and explained in the accompanying commentary (see above) using the information presented in Figure 3. Such a change in thickness is because of the existence of, say, a vertical leg/flange along one or both edges, such as does arise with an angle/channel shape.

Table 2. Values of the reduction factor (rf) from Equation (3) for the multi-row configuration of two rows of two bolts per row illustrated in Figure 5.

e_2/d	g/d	w/d	rf (Equ. (3))
1.5	4	7	0.34
1.5	8	11	0.26
1.5	12	15	0.20
3	4	10	0.38
4	4	12	0.39

It is noteworthy that when the number of rows is increased from two to three, maintaining $n = 2$, the reduction factor for specific values of e_2/d and g/d are in excess of those reported in Table 1. A higher rf is guaranteed because L_{br} in Equation (A1a) is lower, by 20%, at 0.4.

When both the number of rows and columns of bolt is three the value of rf with practical connection geometry dimensions is found to be always > 0.2 .

The two main findings distilled from this new contribution to knowledge can be summarized as:

1. the simplification to the Hart-Smith design approach for the determination of the strength of multi-row bolted connections failing in net tension at the first bolt row can be reliable to over conservative.
2. the simplified strength formula, which is Equation (4), is valid only when the effective or actual width does not exceed an upper limit; this limit is dependent on the bolted connection configuration and it is unlikely to be specified in practical design solutions.

To complete the exercise of evaluating the performance and reliability of both the simplified strength formula (Equation (4)) and the rigorous Hart-Smith approach, as presented in the appendix, requires a programme of strength tests on multi-row bolted connections that scope the permitted detailing in the clauses of the forthcoming published LRFD standard. Currently, many test results for net tension strengths of multi-rowed bolted connections that are reported in the public domain [11] are found to fail to satisfy one or more of the requirements; often the testing was performed without the nominal clearance hole size (of 1/16th in.) that is always found in field structures in the USA.

CONCLUDING REMARKS

Although the application of the Hart-Smith formulae and accompanying design parameters (such as presented in the appendix to this paper) for the prediction of net tension strength of multi-rowed bolted connections can easily be achieved by introducing them into, for example, an EXCEL spreadsheet, their complexity does encourage simplification for the mandatory clauses in a design standard. In this paper the author introduces the background to the full set of formulae for a rigorous application of the design approach recommend by Hart-Smith [1], and by developing the standard's commentary presents the background for why this approach is appropriate for net tension failure at the first bolt row. Using an analytical parametric study the author shows that there can be a simplification giving a formula that provides a very straightforward hand-calculation to be performed. This strength formula (is Equation (4)) has been specified so that it should always provide the lower bound strength for the range of multi-row bolted connections that are practical and permitted in the LRFD standard in preparation (and to be published by ASCE). It would be remiss not to add that the mode of failure with a

reduction factor of 0.2 may not be net tension. Because it can be shown that the lower bound value can be half that predicted using the rigorous Hart-Smith approach the full set of formulae are to be made available to the designer by way of an appendix in the commentary part to the ASCE standard. When applying the simplified strength formula it is important to recognise that there can be a maximum limit on the effective (or actual) width of the connected component for the strength determined to be valid.

ACKNOWLEDGMENTS

This work was supported by the Engineering and Physical Sciences Research Council [grant number EP/H042628/1 (*Connections and Joints for Buildings and Bridges of Fibre Reinforced Polymer*)]. In developing the design guidance to determine the net tension strength in multi-row bolted connections the author is grateful to scientific support from Professor L. C. Bank (The City College of New York), Professor C. Shield (University of Minnesota) and Dr T. R. Gentry (Georgia Institute of Technology) and members of the project team, such as D. Witcher (Enduro Composites, Houston), when preparing chapter 8 in the ASCE pre-standard [3] and ASCE standard in preparation.

REFERENCES

1. Hart-Smith, L. J., Mechanically-fastened Joints for Advanced Composites - Phenomenological Considerations and Simple Analyses, *Fourth Conference on Fibrous Composites in Structural Design*, Plenum, New York, 543-574, (1978).
2. Mottram, J. T., Prediction of Net-tension Strength for Multi-row Bolted Connections of Pultruded Material using the Hart-Smith Semi-empirical Modeling Approach, *Journal of Composites for Construction*, **(14)**1, 105-114, (2010).
3. *Pre-Standard for Load and Resistance Factor Design (LRFD) of Pultruded Fiber Polymer (FRP) structures (Final)*, American Composites Manufacturer Association (ACMA), 9th November 2010, ACSE, p. 216.
4. Mosallam, A. S., *Design Guide for FRP Composite Connections*, Manuals of Practice (MOP) 102, American Society of Civil Engineers, Reston, WV, (2011).
5. Clarke, J. L., (Ed.), *Structural Design of Polymer Composites*, EUROCOMP Design Code and Handbook, E&FN Spon, London, (1996).
6. McCarthy, M. A., McCarthy, C. T. and Padhi, G. S., *A Simple Method for Determining the Effects of Bolt-hole Clearance on Load Distribution in Single-column Multi-bolt Composite Joints*, *Composite Structures*, **(73)**1, 78-81, (2006).
7. Turvey, G. J. and Wang, P. Open-hole Tension Strength of Pultruded GRP Plates, *Structures and Buildings*, **156**(1), 93-101, (2003).
8. Hassan, N. K., Mohamedien, M. A. and Rizkalla, S. H., Multibolted Joints for GFRP Structural Members, *Journal of Composites for Construction*, **1**(1), 3-6, (1997).
9. Rosner, C. N. and Rizkalla, S. H., Bolted Connections for Fiber-reinforced Composite Structural Materials: Experimental Program, *Journal of Materials in Civil Engineering*, **7**(4), 223-231, (1995).
10. Hassan, N. K., Mohamedien, M. A. and Rizkalla, S. H., Rational Model for Multibolted Connections for GFRP Members, *Journal of Composites for Construction*, **1**(2), 71-78, (1997).
11. Mottram, J. T. and Turvey G. J., Physical Test Data for the Appraisal of Design Procedures for Bolted Joints in Pultruded FRP Structural Shapes and Systems, *Progress in Structural Engineering and Materials*, **5**(4), 195-222, (2003).

APPENDIX. BOLTED CONNECTIONS WITH TWO OR THREE ROWS OF BOLTS – FULL FORMULAE

The following is the full treatment to determine the strength of multi-row bolted connections of pultruded FRP material that are in accordance with the specification in the standard under preparation [3]. In the mandatory part of the standard the strength formula given by Equation

(A1a) has been simplified, and this formula is given by Equation (4) above. As a consequence of the simplification process Equation (4) will not always give the most efficient design for a multi-row bolted connection. An increase in connection strength (relative to wtF_L^t) may be achieved by establishing the multi-row bolted connection strength using the provisions given next.

Load Distribution per Bolt Row

Table A1 gives the load distribution per bolt row as a proportion of the connection force transmitted through bearing. It is assumed that each row has the same number of bolts, up to a maximum number of three, and that each bolt in a row bears an equal part of the load resisted by that row. The proportion of the load not resisted by the first row is assumed to be taken as the by-pass load $(1 - L_{br})$ in Section A1.

Table A1. Load distributions for multi-bolted connections with two or three bolt rows.

Materials connected	No. of rows, n	Proportion of load at first row ^[a] , L_{br}	Proportion of load at second row	Proportion of load at third row
FRP/FRP	2	0.5	0.5	----
FRP/steel	2	0.6	0.4	----
FRP/FRP	3	0.4	0.2	0.4
FRP/steel	3	0.5	0.3	0.2

Notes: [a] First row of bolts is the farthest from the end edge of the connection.

A1 Net Tension Strength at First Bolt Row, $R_{nt,f}$

For determination of net tension strength, $R_{nt,f}$, the bolt loading at the first row is taken as the load distribution proportions in Table A1. To illustrate the design approach the formulae given next are for the situation where the connection force is between 0° and 5° to the longitudinal direction of FRP material and perpendicular to the bolt rows, with constant pitch spacing, s , the connection net tension strength is to be given by:

$$R_{nt,f} = \left[\left(K_{nt,L} L_{br} \left(\frac{w}{nd} \right) \right) + \left(\frac{K_{op,L} (1 - L_{br})}{\left(1 - n \left(\frac{d_n}{w} \right) \right)} \right) \right]^{-1} wt F_L^t \quad (A1a)$$

where

- t = Minimum thickness of the connected members
- d = Bolt diameter
- d_n = Nominal hole diameter
- n = Number of bolts across the effective width, $n = 1$ to 3.
- L_{br} = Proportion of the connection force taken in bearing at the first bolt row
- F_L^t = Characteristic tensile strength in the longitudinal direction of the FRP material
- w = effective width.

For a connection with a single bolt per row ($n = 1$ and $S_{pr} = w/d$):

$K_{nt,L}$ in Equation (A1a) is given as follows:

$$K_{nt,L} = \frac{1}{\left(\frac{w}{d} - 1 \right)} \left(1 + C_L \left(S_{pr} - 1.5 \left(\frac{S_{pr} - 1}{S_{pr} + 1} \right) \Theta \right) \right) \quad (A2a)$$

with $\Theta = 1.5 - 0.5 \frac{w}{e_1}$ for $\frac{e_1}{w} \leq 1$, $\Theta = 1$ for $\frac{e_1}{w} \geq 1$, and e_1 is end distance from centre of bolt hole of row nearest free end to that free end.

For FRP members of a pultruded shape take $C_L = 0.50$. For pultruded plate material take $C_L = 0.40$.

The effective width (w) in Equations (A1a) and (A2a) is to be $w = e_3 + e_4$, and:

- $e_3 = e_4 = e_2$, for a connection with two side edges having a side distance e_2 ;
- $e_3 = e_2$, $e_4 = 2e_{2,min}$, for a connection with one side edge having side distance e_2 and with the other side distance $> 2e_{2,min}$;
- $e_3 = e_4 = 2e_{2,min}$, for a connection having its two side edges with side distance $> 2e_{2,min}$.

$K_{op,L}$ in Equation (A1a) is given by:

$$K_{op,L} = 1 + C_{op,L} \left(1 + \left(1 - \frac{1}{S_{pr}} \right)^3 \right) \quad (A3a)$$

For pultruded material from a shape or plate, take $C_{op,L} = 0.50$.

For rows of bolts with constant gage spacing across the effective width ($n = 2$ or 3 take $S_{pr} = g/d$):

$K_{nt,L}$ in Equation (A1a) is given as follows:

$$K_{nt,L} = \frac{1}{\left(\frac{w}{nd} - 1 \right)} \left(1 + C_L \left(S_{pr} - 1.5 \frac{(S_{pr} - 1)}{(S_{pr} + 1)} \Theta \right) \right) \quad (A2b)$$

with $\Theta = 1.5 - 0.5 \frac{g}{e_1}$ for $\frac{e_1}{g} \leq 1$, and $\Theta = 1$ for $\frac{e_1}{g} \geq 1$.

For FRP members of a pultruded shape take $C_L = 0.50$. For pultruded plate material take $C_L = 0.40$.

The effective width (w) in Equations (A2a) and (A22b) is to be $w = e_3 + e_4 + (n - 1)g$, where n is number of bolts across the effective width ($n_{max} = 3$), and:

- $e_3 = e_4 = e_2$, for a connection with two side edges having a side distance e_2 ;
- $e_3 = e_2$, $e_4 = 2e_{2,min}$, for a connection with one side edge having side distance e_2 and with the other side distance $> 2e_{2,min}$;
- $e_3 = e_4 = 2e_{2,min}$, for a connection having its two side edges with side distance $> 2e_{2,min}$.

$K_{op,L}$ in Equation (A1a) is given by:

$$K_{op,L} = 1 + C_{op,L} \left(1 + \left(1 - \frac{1}{S_{pr}} \right)^3 \right) \quad (A3b)$$

For pultruded material from a shape or plate, take $C_{op,L} = 0.50$.

The change made when the connection force is between 5° and 90° is that the Longitudinal properties in Eqs. (A1a) to (A3b) are replaced by their Transverse equivalents. Transverse properties are those for the orientation of the material at 90° to that of the direction of pultrusion.