



PROJECT MUSE®

Polynomial diffeomorphisms of \mathbb{C}^2 . VIII: quasi-expansion

Eric Bedford, John Smillie

American Journal of Mathematics, Volume 124, Number 2, April 2002,
pp. 221-271 (Article)

Published by The Johns Hopkins University Press
DOI: 10.1353/ajm.2002.0008



➔ For additional information about this article

<http://muse.jhu.edu/journals/ajm/summary/v124/124.2bedford.html>

POLYNOMIAL DIFFEOMORPHISMS OF \mathbf{C}^2 . VIII: QUASI-EXPANSION

By ERIC BEDFORD and JOHN SMILLIE

Abstract. We introduce the notion of quasi-expansion in the context of polynomial diffeomorphisms of \mathbf{C}^2 . Like hyperbolic diffeomorphisms, quasi-expanding maps have uniformly large multipliers at saddle points. On the other hand, unlike the hyperbolic case, quasi-expanding maps can have tangencies between stable and unstable manifolds. We characterize quasi-expansion in a number of ways and develop some of the structure they possess. Quasi-expansion was motivated by the study of real polynomial diffeomorphisms of maximal entropy, and our study of maximal entropy diffeomorphisms relies on the results of this paper.

0. Introduction. This paper continues our investigation of the dynamics of polynomial diffeomorphisms of \mathbf{C}^2 carried out in [BS1-7]. There are several reasons why the polynomial diffeomorphisms of \mathbf{C}^2 form an interesting family of dynamical systems. Not the least of these is the fact that there are connections with two other areas of dynamics: polynomial maps of \mathbf{C} and diffeomorphisms of \mathbf{R}^2 , which have each received a great deal of attention. The fact that these three areas are linked makes it interesting to understand different dynamical notions in these three contexts. One of the fundamental ideas in dynamical systems is hyperbolicity. A lesson from the study of the dynamics of maps of \mathbf{C} is that hyperbolicity does not stand alone as a dynamical property, rather, it is one of a sequence of interesting properties which can be defined in terms of recurrence properties of critical points. These one-dimensional properties include the critical finiteness property, semi-hyperbolicity, the Collet-Eckmann property and others. In this paper we introduce a dynamical property of polynomial diffeomorphisms that generalizes hyperbolicity in the way that semi-hyperbolicity generalizes hyperbolicity for polynomial maps of \mathbf{C} . This paper was motivated in part by the study of real polynomial diffeomorphisms of maximal entropy; these maps provide examples which can be analyzed by the techniques of this paper.

In one-dimensional complex dynamics, generalizations of hyperbolicity are typically defined in terms of recurrence properties of critical points. Since we are dealing with diffeomorphisms of \mathbf{C}^2 there are no critical points, and we must use other methods. One way to approach expansion properties is via a certain canonical metric which we define on unstable tangent spaces of periodic saddle points. A mapping is said to be *quasi-expanding* if this metric is uniformly expanded.

Manuscript received October 12, 2000.

Research of both authors supported by the National Science Foundation.

American Journal of Mathematics 124 (2002), 221–271.

Although this metric is canonical, it need not be equivalent to the Euclidean metric. It follows that quasi-expansion need not correspond to uniform expansion in the usual sense. We will see in fact that quasi-expansion is strictly weaker than uniform expansion. If both f and f^{-1} are quasi-expanding, we say that f is quasi-hyperbolic. We will show in this paper that quasi-hyperbolic diffeomorphisms have a great deal of interesting structure. Using this structure we develop a criterion for showing that certain quasi-expanding diffeomorphisms are uniformly hyperbolic. This criterion for hyperbolicity (as well as the general structure of quasi-hyperbolic diffeomorphisms) plays an important role in the study of real diffeomorphisms of maximal entropy which is carried out in [BS]. In Theorem 4.8 we show that a real mapping of maximal entropy is quasi-expanding. In Sections 5 through 8, we obtain more detailed properties of quasi-expanding maps which are, in some sense, post-critically finite. In [BS] it is shown that real maps of maximal entropy have this post-critical finiteness property; and the results of Sections 5–8 are then used in [BS].

We now define the metric on which the definition of quasi-expansion is based. This metric is “canonical” in the sense that its construction depends only on the choice of a Green function which is unique up to a multiplicative constant. In Theorem 4.5 we show that all of these metrics are equivalent. Let \mathcal{S} denote the set of saddle points of f , and we let J^* denote the closure of \mathcal{S} . For $p \in \mathcal{S}$ we let $W^u(p)$ denote the unstable manifold through p , and we let E_p^u denote its tangent space at p . $W^u(p)$ has the structure of a Riemann surface immersed in \mathbf{C} , and there is a conformal uniformization $\psi_p: \mathbf{C} \rightarrow W^u(p)$ with the property that $\psi_p(0) = p$. We may normalize ψ_p by the condition that $\max_{|\zeta| \leq 1} G^+ \circ \psi_p(\zeta) = 1$. We may define a norm $\|\cdot\|^\#$ on E_p^u by the condition that the differential of ψ_p with respect to the euclidean metric on \mathbf{C} has norm 1 at the origin. A mapping is said to be *quasi-expanding* if this metric is expanded by a constant $\kappa > 1$ for all $p \in \mathcal{S}$.

In Section 1 we describe several conditions which are equivalent to quasi-expansion. One such condition is that the family of uniformizations $\{\psi_p : p \in \mathcal{S}\}$ is a normal family of entire functions. Quasi-expansion is a property of diffeomorphisms. In Section 2 we consider related properties of individual orbits.

Let Ψ denote the set of normal limits of $\{\psi_p : p \in \mathcal{S}\}$, and let $\mathcal{W}^u = \{\psi(\mathbf{C}) : \psi \in \Psi\}$. In Section 3 we consider $\psi(\mathbf{C})$ purely as a variety, that is to say without regard to its parametrization. For fixed $r > 0$ we let $B(p, r)$ denote the ball in \mathbf{C}^2 with center p and radius r . We let $W^u(p, r)$ denote the connected component of $B(p, r) \cap W^u(p)$ containing p . We say that f satisfies the *bounded area condition* if there exists $r > 0$ such that for all $p \in \mathcal{S}$, $W_r^u(p)$ is closed in $B(p, r)$, and the area of $W^u(p, r)$ is bounded above. Every quasi-expanding map satisfies the bounded area condition. By Bishop’s Theorem and Lemma 2.6, the correspondence $\mathcal{S} \ni p \mapsto W^u(p, r)$ extends to a continuous family of varieties $J^* \ni x \mapsto V^u(x, r)$ such that $V^u(p, r) = W^u(p, r)$ for $p \in \mathcal{S}$. We prove a *Bounded*

Area Distortion Theorem for proper holomorphic mappings of planar domains into \mathbb{C}^n (Theorems 3.1–2). This is used to prove Theorem 3.4, which says that the locally bounded area condition, together with a generalized transversality condition, imply quasi-expansion. The bounded area condition also allows us to prove that uniform hyperbolicity implies quasi-expansion.

The metric that we define is canonical, but it is not the only canonical metric that can be defined. In Section 4, we consider various methods of defining metrics on unstable tangent spaces E_p^u for $p \in \mathcal{S}$. We consider the equivalence of uniform expansion for various choices of metrics. In particular, we define the metrics $\|\cdot\|^{(L)}$ and show that they are uniformly expanded by real mappings with maximal entropy. We show that the uniform expansion of this metric implies quasi-expansion.

For $x \in J^*$ we let Ψ_x denote the maps $\psi \in \Psi$ with $\psi(0) = x$. Such a map has the form $\psi(\zeta) = x + a_j \zeta^j + O(\zeta^{j+1})$, and we define the order of ψ to be j . We use the notation $\tau(x)$ for the maximum order for a function $\psi \in \Psi_x$. We let $\mathcal{J}_j = \{x \in J^* : \tau(x) = j\}$. For $x_0 \in \mathcal{J}_1$, every function $\psi \in \Psi$ has nonvanishing differential at the origin. Thus \mathcal{W}^u is a lamination in a neighborhood of every point of \mathcal{J}_1 . (In Section 6, \mathcal{J}_1 will be shown to be a dense, open subset of J^* .) In Section 5, we show that τ describes the local folding of \mathcal{W}^u . In particular, \mathcal{W}^u is not a lamination in the neighborhood of x_1 if $\tau(x_1) > 1$.

In Section 6, we define a metric $\|\cdot\|_x^\#$ at all points $x \in J^*$. This metric (in general not equivalent to the Euclidean metric) is uniformly expanded if f is quasi-expanding. It follows (Theorem 6.2) that the largest Lyapunov exponent of a quasi-expanding mapping with respect to any ergodic invariant measure is strictly positive. In particular it follows (Corollary 6.3) that all periodic points in J^* are saddle points and that the Lyapunov exponents of periodic orbits are uniformly bounded away from 0.

Starting with Section 7 our work applies to mappings for which both f and f^{-1} are quasi-expanding. Regularity of the variety V_x at x is shown for points $x \in \mathcal{J}_j$ such that $\alpha(x) \cap \mathcal{J}_j \neq \emptyset$. We also show that a tangency between \mathcal{W}^u and \mathcal{W}^s at a point $x \in J^*$ causes $\tau(\hat{x}) > 1$ for $\hat{x} \in \alpha(x)$.

In Section 8 we examine uniform hyperbolicity more carefully. In Theorem 8.3 we show that there are geometric properties of J^\pm which imply hyperbolicity. In Theorem 8.3, we show that: If f, f^{-1} are quasi-expanding, and if f is topologically expansive, then f is uniformly hyperbolic. Finally, if f and f^{-1} are both quasi-expanding, we define the singular set \mathcal{C} to be the points of J^* where $\max(\tau^s, \tau^u) > 1$. Let \mathcal{T} denote the points of tangency between \mathcal{W}^s and \mathcal{W}^u . In Theorem 8.10 we show that if f is a mapping for which \mathcal{C} is finite and nonempty, then $\mathcal{T} \subset W^s(\mathcal{C}) \cap W^u(\mathcal{C})$, and $\bar{\mathcal{T}} - \mathcal{T} = \mathcal{C}$.

One of our motivations in studying quasi-expansion was to develop the two-dimensional analogue of semi-hyperbolicity. In the Appendix, we work out these ideas in dimension one, and we show that the one-dimensional analogue of quasi-expansion is equivalent to semi-hyperbolicity.

Notation	Section
$B(p, r), W^u(p, r), E_p^u$	§0,1
$\ \cdot \ _x^\#, \ \cdot \ ^\#$	§1,4,6
$m_x, L_x, \psi_x, \tilde{f}$	§1
$\lambda_x, \lambda(\psi, n), m(r), \psi_S$	§1
$\hat{\lambda}_x, \hat{\lambda}(x, n), r_x, R_x$	§2
$\Psi_x, \Psi, V(x, \epsilon), V(\psi, \epsilon), \tilde{V}_x$	§2
conditions †, ‡	§2
<i>forward contraction, backward expansion</i>	§2,7
$W_x^e(z)$	§3
$\ \cdot \ _x^e, \ \cdot \ ^{(L)}, a_\delta^*, c^*, \tilde{\psi}_S$	§4
<i>eventually positive, immediately positive</i>	§4
<i>admissible</i>	§4
$V(\psi, \mathcal{N}), \tau(x), \text{Ord}(\psi), \mathcal{J}_k$	§5
$\Psi_x^k, \gamma_k(x), \ \cdot \ _x^{\#k}, \Lambda(\nu), \mathcal{J}'_k$	§6
<i>homogeneous parametrization</i>	§6
$V^u, \Psi^u, E^u, \gamma^u, \tau^u, V^s, \Psi^s, E^s, \gamma^s, \tau^s$	§7
$\mathcal{J}_{j,k}, \tau^l, \mathcal{J}_{j,k}^i$	§7
$\iota_x(V_1, V_2), \mu_x(V), \mathcal{C}, \mathcal{T}$	§8
$\mathcal{C}, \mathcal{P}(\mathcal{C}), \mathcal{C}'_x$	§A

Acknowledgments. We wish to thank the referee for reading the paper carefully and making several helpful comments.

1. Normal families of uniformizations. We say that a holomorphic map $\phi: \mathbf{C} \rightarrow \mathbf{C}^2$ is an *injective immersion* (or simply *immersion* if no confusion will result) if it is injective and an immersion, which means that $\phi'(\zeta) \neq 0$ for all $\zeta \in \mathbf{C}$. In this section we explore the condition that a set of immersions has uniform expansion; we show that, in the language of function theory, this is equivalent to the set of immersions being a normal family of entire functions. Let $S \subset J^*$ be a dense, f -invariant set. Suppose that for each $x \in S$ there is a holomorphic immersion $\psi_x: \mathbf{C} \rightarrow \mathbf{C}^2$ such that

$$(1.1) \quad x \in \psi_x(\mathbf{C}), \text{ and } \psi_x(\mathbf{C}) \subset J^-.$$

In addition, suppose that the family of sets $\{\psi_x(\mathbf{C}) : x \in S\}$ is f -invariant, i.e.,

$$(1.2') \quad f(\psi_x(\mathbf{C})) = \psi_{f(x)}(\mathbf{C})$$

and satisfies: for $x_1, x_2 \in S$, either $\psi_{x_1}(\mathbf{C})$ and $\psi_{x_2}(\mathbf{C})$ are either disjoint, or they coincide, i.e.,

$$(1.2'') \quad \psi_{x_1}(\mathbf{C}) \cap \psi_{x_2}(\mathbf{C}) \neq \emptyset \Rightarrow \psi_{x_1}(\mathbf{C}) = \psi_{x_2}(\mathbf{C}).$$

For any holomorphic immersion $\phi: \mathbf{C} \rightarrow \mathbf{C}^2$ with $\phi(\mathbf{C}) = \psi_x(\mathbf{C})$, there are constants $a, b \in \mathbf{C}, a \neq 0$ such that $\phi(\zeta) = \psi_x(a\zeta + b)$. We may choose a and b to

obtain the normalization properties:

$$(1.3) \quad \psi_x(0) = x, \quad \max_{|\zeta| \leq 1} G^+(\psi_x(\zeta)) = 1.$$

The first condition in (1.3) may be achieved by a translation of ζ . To see that the second normalization is always possible, we note that since $x \in J^*$, $G^+(x) = G^+(\psi_x(0)) = 0$. Thus

$$m_x(r) := \max_{|\zeta| \leq r} G^+(\psi_x(\zeta))$$

satisfies $m_x(0) = 0$ and is a continuous, monotone increasing function which is unbounded above. So after a scaling of ζ , we will have $m_x(1) = 1$. We note that this normalization defines the parametrization of ψ_x uniquely, up to replacing ζ by a rotation $e^{i\theta}\zeta$, $\theta \in \mathbf{R}$.

By $\psi_S = \{\psi_x : x \in S\}$ we denote the family of these immersions, normalized by (1.3). For $x \in S$ there is a linear mapping $L_x: \mathbf{C} \rightarrow \mathbf{C}$, $L_x(\zeta) = \lambda_x \zeta$, and the family $\{L_x : x \in S\}$ has the property

$$(1.4) \quad f \circ \psi_x = \psi_{f_x} \circ L_x.$$

Changing the parametrization of ψ_x or ψ_{f_x} by a rotation induces a rotation on L_x . f induces a mapping \tilde{f} of ψ_S to itself, given by

$$(1.5) \quad \tilde{f}(\psi_x) = \psi_{f_x} = f \circ \psi_x \circ L_x^{-1}.$$

For $n > 0$ set

$$(1.6) \quad \lambda(x, n) = \lambda_x \lambda_{f_x} \cdots \lambda_{f^{n-1}x}$$

so that

$$(1.7) \quad \tilde{f}^n(\psi_x)(\zeta) = f^n \circ \psi_x(\lambda(x, n)^{-1} \zeta) = f^n \circ \psi_x(\lambda(\psi, n)^{-1} \zeta),$$

where we introduce and define the notation $\lambda(\psi, n)$ in the right-hand side of (1.7). This will be useful in the sequel in cases where ψ is not unique. For convenience here we define $\lambda(\psi, n)$ as a complex number, but it is actually the modulus of $\lambda(\psi, n)$ that plays an important role in what follows.

By the identity $G^+ \circ f = d \cdot G^+$ and the transformation formula (1.2'), we have

$$(1.8) \quad d \cdot m_x(r) = m_{f_x}(|\lambda_x| r).$$

Setting $r = 1$, we have $d = m_{f_x}(|\lambda_x|) > 1$, which gives $|\lambda_x| > 1$ for all $x \in S$.

For $x \in S$, we let E_x^u denote the subspace of the tangent space of $T_x \mathbf{C}^2$ given by the \mathbf{C} -linear span of $\psi'_x(0)$. If $v \in E_x^u$, then v is a scalar multiple of $\psi'_x(0)$, so

we define the norm

$$(1.9) \quad \|v\|_x^\# := |v/\psi'_x(0)|.$$

It follows that the norm of Df_x , measured with respect to this family of norms is given by

$$\|Df_x|_{E_x^u}\|^\# = \max_{v \in E_x^u - \{0\}} \frac{\|Df_x v\|_{f_x}^\#}{\|v\|_x^\#} = |\lambda_x|.$$

Similarly, $\|Df_x^n|_{E_x^u}\|^\# = |\lambda(x, n)|$.

For $1 \leq r < \infty$ we define

$$M(r) = \sup_{x \in S} m_x(r).$$

For each $x \in S$, $m_x(r)$ is a convex, increasing function of $\log r$. It follows that $M(r)$ also has these properties on the open interval where it is finite. In particular, $M(r)$ is continuous from the right at $r = 1$, $M(1) = 1$, and $M(r) > 1$ if $r > 1$.

LEMMA 1.1. *ψ_S is a normal family if and only if $M(r) < \infty$ for all $r < \infty$.*

Proof. We set $V = \{|x|, |y| \leq R\}$ and $V^+ = \{|y| \geq |x|, |y| \geq R\}$. It is known that for R sufficiently large, $K^- \subset V \cup V^+$, $S \subset V$, and $G^+|_{V \cup V^+}$ is a proper exhaustion. Since $\psi_x(0) = x \in S$, it follows that no sequence in ψ_S can diverge to infinity uniformly on compacts. Thus normality is equivalent to local boundedness at every point. For fixed $\zeta \in \mathbf{C}$ the sequence $\{\psi_{x_j}(\zeta)\}$ is bounded if and only if $\{G^+(\psi_{x_j}(\zeta))\}$ is bounded. Since $M(r)$ is increasing in r , it follows that if $M(r) < \infty$, then Ψ is a normal family on $\{|\zeta| < r\}$.

Conversely, if ψ_S is a normal family, then $\{G^+(\psi(\zeta)) : \psi \in \Psi, |\zeta| \leq r\}$ is bounded. Thus $M(r) < \infty$. □

The following result shows that the normal family condition is equivalent to a number of “uniform conditions.”

THEOREM 1.2. *The following are equivalent:*

- (1) ψ_S is a normal family.
- (2) $M(r_0) < \infty$ for some $1 < r_0 < \infty$.
- (3) For all $r_1 < r_2 < \infty$ there is a constant $k < \infty$ such that $m_x(r_2)/m_x(r_1) \leq k$ for all $x \in S$.
- (4) There exists $\kappa > 1$ such that for all $x \in S$, $|\lambda_x| \geq \kappa$.
- (5) Condition (1.10) holds:

$$(1.10) \quad \text{There exist } C, \beta < \infty \text{ such that } m_x(r) \leq Cr^\beta \text{ for all } x \in S \text{ and } r \geq 1.$$

Proof. (1) \Rightarrow (2) is a consequence of Lemma 1.1.

(2) \Rightarrow (4). If $M(r_0) < \infty$ for some $1 < r_0 < \infty$ then $M(r)$ is a convex, increasing function of $\rho = \log r$ on the interval $\rho \in (0, \log r_0)$. It follows that

$M(r)$ is continuous at $r = 1$. Thus $\kappa := \inf\{t \geq 1 : M(t) \geq d\} > 1$. Now for any $x \in S$ we have $m_{f^j}(|\lambda_x|) = d \cdot m_x(1) = d$. It follows, then, that $M(|\lambda_x|) \geq d$, and so $|\lambda_x| \geq \kappa > 1$.

(4) \Rightarrow (5). For $x \in S$, let $x_j = f^j x$. Then by the transformation formula (1.8)

$$m_x(\kappa^p) \leq m_x(|\lambda_{x_0} \lambda_{x_{-1}} \cdots \lambda_{x_{-p+1}}|) = d^p m_{x_{-p+1}}(1) = d^p.$$

For any $1 \leq r < \infty$ we choose p such that $\kappa^{p-1} \leq r < \kappa^p$. If we choose $\beta = \log d / \log \kappa$, then $\kappa^\beta = d$, and

$$m_x(r) \leq m_x(\kappa^p) \leq (\kappa^p)^\beta = \kappa^\beta r^\beta.$$

Thus (1.10) holds with $C = \kappa^\beta$.

(5) \Rightarrow (1). Condition (1.10) implies that $M(r) \leq Cr^\beta$, and thus ψ_S is a normal family by Lemma 1.1.

(1) \Leftrightarrow (3). Let $\tilde{\psi}_S$ denote the set of scaled functions $\tilde{\psi}(\zeta) = \psi(r_1 \zeta)$ for all $\psi \in \psi_S$. By the equivalence (1) \Leftrightarrow (2) and Lemma 1.1, we have that $\tilde{\psi}_S$ is a normal family if and only if

$$\tilde{M}(r) := \sup_{x \in S} \frac{\tilde{m}_x(r)}{\tilde{m}_x(1)} = \sup_{x \in S} \frac{m_x(rr_1)}{m_x(r_1)} < \infty.$$

Finally, it is evident that ψ_S is a normal family if and only if $\tilde{\psi}_S$ is normal. Thus (1) is equivalent to (3). □

We say that f is *quasi-expanding* if the equivalent conditions in Theorem 1.2 hold. While these conditions are stated in terms of the family ψ_S , we will see in Section 3 that they are independent of the choice of the particular family ψ_S . We say that f is *quasi-contracting* if f^{-1} is quasi-expanding.

PROPOSITION 1.3. *For $n \geq 1$, f is quasi-expanding if and only if f^n is quasi-expanding.*

Proof. Let ψ_S be a family satisfying (1.1–3) for f . For $n \geq 1$, J^* and K^+ are the same for f^n . It follows that ψ_S also satisfies (1.1–3) for f^n . If f is quasi-expanding, then ψ_S is a normal family; thus f^n , too, is quasi-expanding.

Now suppose that ψ_S satisfies (1.1–3) for f^n . It follows that $\tilde{S} := S \cup fS \cup \cdots \cup f^{n-1}S$ is f -invariant. Let $\psi_S^{(j)}$ denote the set of mappings $\{f^j \circ \psi \circ L_\lambda : \psi \in \psi_S\}$, where $L_\lambda(\zeta) = \lambda(\psi, j)\zeta$ is chosen so that $f^j \circ \psi \circ L_\lambda$ satisfies the normalization (1.3). Let $\tilde{\psi}_S := \psi_S^{(0)} \cup \cdots \cup \psi_S^{(n-1)}$, so that $\tilde{\psi}_S$ satisfies (1.1–3) for f . Define $M^{(j)}(r) = \sup_{\psi \in \psi_S^{(j)}} \sup_{|\zeta| \leq r} G^+ \circ \psi(\zeta)$. If f^n is quasi-expanding, then $\psi_S^{(0)}$ is a normal family. By Lemma 1.1 this means that $M^{(0)}(r) < \infty$ for $r < \infty$. As in

the line following (1.8) we have $|\lambda(\psi, j)| \geq 1$. It follows that

$$\begin{aligned} M^{(j)}(r) &= \sup_{\psi \in \psi_S^{(j)}} \sup_{|\zeta| \leq r} G^+ \circ \psi(\zeta) \\ &= \sup_{\psi \in \psi_S^{(0)}} \sup_{|\zeta| \leq r} d \cdot G^+ \circ \psi(|\lambda(\psi, j)|^{-1} \zeta) \leq d \cdot M^{(0)}(r). \end{aligned}$$

Thus $M^{(j)}(r) < \infty$ for all $r < \infty$. It follows from Lemma 1.1 that each ψ_S^j is a normal family. Thus $\tilde{\psi}_S$ is normal, and f is quasi-expanding. \square

PROPOSITION 1.4. *If f is quasi-expanding, then for $x \in S$, $\psi_x(\mathbf{C}) \subset W^u(x)$, i.e., if $y_1, y_2 \in \psi_x(\mathbf{C})$, then $\lim_{n \rightarrow +\infty} \text{dist}(f^{-n}y_1, f^{-n}y_2) = 0$.*

Proof. For $j = 1, 2$ there exist $\zeta_j \in \mathbf{C}$ such that $\psi_x(\zeta_j) = y_j$. By (1.7) $f^{-n}y_j = f^{-n}\psi_x(\zeta_j) = \psi_{x-n}(\lambda(x, -n)^{-1}\zeta_j)$. Now $\{\psi_{x-n} : n \geq 0\}$ is a normal family, so the set of derivatives $\{|D\psi_{x-n}(\zeta)| : |\zeta| \leq 1, n \geq 0\}$ is uniformly bounded by $M < \infty$. Thus

$$\begin{aligned} \text{dist}(f^{-n}y_1, f^{-n}y_2) &= |\psi_{x-n}(\lambda(x, -n)^{-1}\zeta_1) - \psi_{x-n}(\lambda(x, -n)^{-1}\zeta_2)| \\ &\leq |\lambda(x, -n)|^{-1}M|\zeta_1 - \zeta_2|, \end{aligned}$$

which tends to zero, since $\lambda(x, -n) \rightarrow \infty$ by (4) of Theorem 1.2. \square

We give two examples to show that families ψ_S satisfying (1.1–3) exist for any map f . Let p be a saddle point, i.e., a periodic point of saddle type. The stable and unstable manifolds $W^s(p)$ and $W^u(p)$ through p are conformally equivalent to \mathbf{C} . Let $\phi: \mathbf{C} \rightarrow W^u(p)$ denote a uniformization of the unstable manifold. It is evident that $p \in \phi(\mathbf{C}) = W^u(p)$, and by the argument of [BS1, Proposition 5.1] we have $W^u(p) \subset J^-$.

Example 1. Let p and q be saddle points, and set $S = W^s(q) \cap W^u(p)$. By [BLS], S is a dense subset of J^* . Let ϕ denote the uniformization of $W^u(p)$ as above. For $x \in S \subset W^u(p)$, we set $\beta_x := \phi^{-1}(x)$. Now we may choose $\alpha_x \neq 0$ such that $\psi_x(\zeta) := \phi(\alpha_x(\zeta + \beta_x))$ satisfies (1.1–3).

Example 2. Let S denote the set of saddle (periodic) points. By [BLS], S is dense in J^* . For $p \in S$ the unstable manifold $W^u(p)$ may be normalized to satisfy the conditions (1.1–3) above.

If p is periodic of period $n = n_p$, then the multiplier $Df_p^n|_{E_p^u}$ is given by $\lambda(p, n)$. Then we have

$$d^n m_p(r) = m_p(|\lambda(p, n)|r).$$

Thus we conclude that for $p \in S$

$$(1.11) \quad m_p(r) \leq C_p r^\beta$$

holds with $\beta = \log d / (\frac{1}{n} \log |\lambda(p, n)|)$. This condition (1.11) allows both C and β to vary with p and differs from (1.10) in this respect.

A variant of (1.10) is

$$(1.12) \quad \text{There exist } C, \beta < \infty \text{ such that } \inf_{y \in S} m_y(r) \geq \frac{r^\beta}{C} \text{ for all } 0 < r < 1.$$

PROPOSITION 1.5. *If f is quasi-expanding, then (1.12) holds.*

Proof. If f is quasi-expanding, then there exists $\kappa > 1$ such that $|\lambda_\psi| \geq \kappa$ for all $\psi \in \Psi$. Given r , choose n such that $\kappa^{-n} \leq r < \kappa^{-n+1}$. By the normalization condition, $m_\psi(|\lambda(\psi, -n)|) = d^{-n}$. Thus by the choice of n ,

$$m_\psi(r) \geq m_\psi(\kappa^{-n}) \geq m_\psi(|\lambda(\psi, -n)|) = d^{-n} \geq d^{\frac{\log r}{\log \kappa} - 1}.$$

Thus (1.12) holds with $C = d$ and $\beta = \log d / \log \kappa$. □

COROLLARY 1.6. *If f is quasi-expanding, there are $C > 0, r_0 > 0$, and $m < \infty$ such that $\max_{B(x,r)} G^+ \geq Cr^m$ for $x \in J^*$ and $0 < r < r_0$.*

2. Expansion along individual orbits and unstable germs. While our primary focus is the dynamics of quasi-expanding diffeomorphisms, some of the results in the sequel are local results and depend only on information about the behavior of a particular orbit. In this section we explore various orbitwise notions of expansion and regularity. This section may be omitted on a first reading of this paper. We define

$$M_x(r) = \limsup_{S \ni y \rightarrow x} m_y(r), \quad \hat{\lambda}_x = \liminf_{S \ni y \rightarrow x} |\lambda_y|$$

$$r_x = \inf\{r : M_x(r) > 0\}, \quad R_x = \inf\{r : M_x(r) = \infty\},$$

where we admit $+\infty$ as a possible value. It follows that $\hat{\lambda}_x \geq 1, M_x(0) = 0, M_x(1) = 1$, and $R_x \geq 1$. Further, M_x is a convex, increasing function of $\log r$ for r in the interval $(0, R_x)$, and it is evident that $x \mapsto M_x$ and $x \mapsto r_x$ are upper semicontinuous; and $x \mapsto \hat{\lambda}_x$ and $x \mapsto R_x$ are lower semicontinuous.

For $n \geq 0$, we define

$$\hat{\lambda}(x, n) = \hat{\lambda}_x \hat{\lambda}_{f_x} \cdots \hat{\lambda}_{f^{n-1}x}, \quad \text{and} \quad \hat{\lambda}(x, -n) = \hat{\lambda}_{f^{-n}x}^{-1} \cdots \hat{\lambda}_{f^{-1}x}^{-1} = \hat{\lambda}(f^{-n}x, n)^{-1}.$$

LEMMA 2.1. For $x \in J^*$ and $n \geq 0$ we have

$$(2.1) \quad d^n M_x(r) \geq M_{f^n x}(\hat{\lambda}(x, n)r) \text{ and } d^{-n} M_x(r) \leq M_{f^{-n} x}(\hat{\lambda}(x, -n)r).$$

Proof. By (1.8) we have

$$m_{f^n p}(|\lambda(p, n)|r) = d^n m_p(r) \text{ and } m_{f^{-n} x}(r) = d^{-n} m_x(|\lambda(x, -n)|r)$$

for $p \in S$ and $n \geq 0$. Let us fix r and choose a sequence of points $p_j \rightarrow x$ such that $m_{f^n p_j}(\hat{\lambda}(x, n)r) \rightarrow M_{f^n x}(\hat{\lambda}(x, n)r)$. Since the m_{p_j} are convex in $\log r$, then are equicontinuous, so by the lower semicontinuity of $x \mapsto \hat{\lambda}(x, n)$, it follows that $M_{f^n x}(\hat{\lambda}(x, n)r) \leq \limsup_{p_j \rightarrow x} m_{p_j}(\lambda(p_j, n)r) = \limsup_{p_j \rightarrow x} d^n m_{p_j}(r) \leq d^n M_x(r)$. The proof for the other inequality follows by a similar argument, with the only difference being that $x \mapsto \hat{\lambda}(x, -n)$ is upper semicontinuous. \square

PROPOSITION 2.2. For $x \in J^*$ and $n \geq 0$ we have $\hat{\lambda}(x, n)R_x \leq R_{f^n x}$ and $\hat{\lambda}(x, -n)r_x \geq r_{f^{-n} x}$. In particular,

$$(2.2) \quad r_x \leq \hat{\lambda}(x, n)^{-1} \leq 1 \leq \hat{\lambda}(x, -n)^{-1} \leq R_x.$$

Proof. If $r < R_x$, then by Lemma 2.1, we have $M_{f^n x}(\hat{\lambda}(x, n)r) < \infty$. Thus $\hat{\lambda}(x, n)r \leq R_{f^n x}$. The other inequality is similar. \square

THEOREM 2.3. The following are equivalent:

- (1) f is quasi-expanding
- (2) $\hat{\lambda}_x > 1$ for all $x \in J^*$.
- (3) $\inf_{x \in J^*} \hat{\lambda}_x > 1$.
- (4) $R_x > 1$ for all $x \in J^*$.
- (5) $R_x = \infty$ for all $x \in J^*$.
- (6) $\lim_{n \rightarrow -\infty} \hat{\lambda}(x, n) = 0$ for all $x \in J^*$.

Proof. (1) \Rightarrow (2). If f is quasi-expanding then $|\lambda_p| \geq \kappa > 1$ for all $p \in S$. Thus $\hat{\lambda}_x \geq \inf_{p \in S} |\lambda_p| \geq \kappa > 1$. (2) \Rightarrow (3). This follows because $x \mapsto \hat{\lambda}_x$ is lower semicontinuous. (3) \Rightarrow (1). By the definition of $\hat{\lambda}_x$ and the compactness of J^* , $\inf_{p \in S} |\lambda_p| = \inf_{x \in J^*} \hat{\lambda}_x$. If $\kappa := \inf_{x \in J^*} \hat{\lambda}_x > 1$, then $|\lambda_p| \geq \kappa$, so f is quasi-expanding.

(1) \Rightarrow (5). This is condition (5) of Theorem 1.2.

(5) \Rightarrow (4). This is trivial.

(4) \Rightarrow (1). Since $x \mapsto R_x$ is lower semicontinuous, it follows that $R := \inf_{x \in J^*} R_x > 1$. Choose $1 < R' < R$. By the upper semicontinuity of $x \mapsto M_x$, it follows that $\sup_{x \in J^*} M_x(R') < \infty$. Thus f is quasi-expanding by (2) of Theorem 1.2.

(1) \Rightarrow (6). If f is quasi-expanding, then $\hat{\lambda}(x, n) \leq \kappa^n$, so (6) holds.

(6) \Rightarrow (5). If (6) holds, then $R_x = \infty$ by Proposition 2.2, so (5) holds. \square

We say that f has *forward expansion at x* if $\lim_{n \rightarrow +\infty} \hat{\lambda}(x, n) = \infty$, and we say that f has *backward contraction at x* if $\lim_{n \rightarrow -\infty} \hat{\lambda}(x, n) = 0$. By Proposition 2.2, if f has forward expansion at x , then $r_x = 0$; and if f has backward contraction at x , then $R_x = \infty$.

For $x \in J^*$ and $R < R_x$ there is a neighborhood \mathcal{N} of x in J^* such that if $y \in \mathcal{N}$, then $m_y(R) \leq M_x(R) + 1 < \infty$. Thus the restrictions $\{G^+ \circ \psi_y | \{|\zeta| < R\} : y \in \mathcal{N}\}$ are uniformly bounded. Since $\psi_y(\mathbf{C}) \subset J^-$, it follows that the restrictions of $\{\psi_y : y \in \mathcal{N}\}$ to $\{|\zeta| < R\}$ are uniformly bounded and are thus a normal family. We let Ψ_x denote the set of analytic mappings $\psi: \{|\zeta| < R_x\} \rightarrow \mathbf{C}^2$ which are obtained as normal limits $\lim_{y_j \rightarrow x} \psi_{y_j} |_{\{|\zeta| < R_x\}}$ for sequences $y_j \rightarrow x$. We set $\Psi = \bigcup_{x \in J^*} \Psi_x$. In general it may happen that an element $\psi \in \Psi_x$ may be analytically extended to a domain strictly larger than $\{|\zeta| < R_x\}$. The size of the domain $\{|\zeta| < R_x\}$ assures that Ψ is a normal family.

Let us define a condition at a point x :

(†) Ψ_x contains a nonconstant mapping.

Suppose (†) holds, and choose a nonconstant $\psi \in \Psi_x$. We say that ψ is a maximal element of Ψ_x if whenever $\psi(\alpha\zeta)$ also belongs to Ψ_x for some constant $\alpha \in \mathbf{C}$, we have $|\alpha| \leq 1$. By the compactness of Ψ_x , each $\psi \in \Psi_x$ is either maximal or has the form $\psi(\zeta) = \hat{\psi}(\alpha\zeta)$ for some maximal $\hat{\psi}$ and $|\alpha| \leq 1$. Passing to convergent subsequences in (1.7) we see that if $\psi \in \Psi_x$ is maximal, then there are a unique (modulo rotation of variable) linear transformation $L(\zeta) = \lambda_\psi \zeta$ and a unique maximal $\psi_1 \in \Psi_{f_x}$ such that $f \circ \psi \circ L_\psi^{-1} = \psi_1$. This allows us to define

$$(2.3) \quad \tilde{f}: \Psi_x \rightarrow \Psi_{f_x}, \quad \tilde{f}(\psi)(\zeta) = f(\psi(\lambda_\psi^{-1}\zeta)).$$

If ψ is not maximal, and if $\psi(\zeta) = \hat{\psi}(\alpha\zeta)$ is as above, then we set $\tilde{f}(\psi)(\zeta) := \tilde{f}(\hat{\psi})(\alpha\zeta)$.

We use the notation $\psi_j := \tilde{f}^j(\psi)$ and

$$\lambda(\psi, n) = \lambda_{\psi_0} \lambda_{\psi_1} \cdots \lambda_{\psi_{n-1}}$$

so

$$\tilde{f}^n(\psi)(\zeta) = f^n \circ \psi(\lambda(\psi, n)^{-1}\zeta).$$

Since each $\psi \in \Psi$ is a limit of elements of ψ_S , and $\hat{\lambda}_x$ is a lim-inf, we have the following.

COROLLARY 2.4. *If (†) holds at $x \in J^*$, then for $n \geq 0$,*

$$\hat{\lambda}(x, n) = \inf_{\psi \in \Psi_x} |\lambda(\psi, n)| = \min_{\psi \in \Psi_x} |\lambda(\psi, n)|,$$

where the infimum and minimum are taken over all nonconstant elements of Ψ_x . In particular, if x is a point of forward expansion, then for all $\psi \in \Psi$, $|\lambda(\psi, n)| \rightarrow \infty$ and $n \rightarrow +\infty$; and if x is a point of backward contraction, then $|\lambda(\psi, n)| \rightarrow 0$ as $n \rightarrow -\infty$.

COROLLARY 2.5. *Suppose that (\dagger) holds at each $x \in J^*$. If f is not quasi-expanding, then there exists a nonconstant $\psi \in \Psi$ such that $|\lambda(\psi, n)| = 1$ for all $n \leq 0$.*

Proof. If f is not quasi-expanding, then by Theorem 2.3, $R_x = 1$ for some $x \in J^*$. By Proposition 2.2, we have $\hat{\lambda}(x, n) = 1$ for all $n \leq 0$. By Corollary 2.4, there is a nonconstant $\psi^{(n)} \in \Psi_x$ such that $|\lambda(\psi^{(n)}, n)| = 1$. By the compactness of Ψ_x , we may choose a subsequence such that $\psi^{(n_j)} \rightarrow \psi \in \Psi_x$, and ψ has the desired property. \square

Let ψ denote the germ at $\zeta = 0$ of a nonconstant holomorphic map from a neighborhood of the origin in \mathbf{C} to \mathbf{C}^2 . Setting $x = \psi(0)$, it follows that $\{|\zeta| < r, \psi(\zeta) = x\} = \{0\}$ for $r > 0$ sufficiently small. Let $B(x, \epsilon)$ denote the Euclidean ball in \mathbf{C}^2 with center x and radius ϵ , and let $V(\psi, \epsilon)$ denote the connected component of $B(x, \epsilon) \cap \psi(|\zeta| < r)$ containing x . If $\epsilon < \min_{|\zeta|=r} |\psi(\zeta)|$, then $V(\psi, \epsilon)$ is an analytic subvariety of $B(x, \epsilon)$.

LEMMA 2.6. *If (\dagger) holds, the nonconstant elements of Ψ_x define a unique germ of a complex analytic variety at x .*

Proof. Let $\psi_1, \psi_2 \in \Psi_x$ be given, and let V_1, V_2 be the corresponding germs of varieties, defined in some ball $B(x, \epsilon)$. If ψ_1^j, ψ_2^j are sequences from Ψ_x which converge to ψ_1, ψ_2 , respectively, then for j sufficiently large, ψ_1^j, ψ_2^j define subvarieties V_1^j, V_2^j (respectively) of $B(x, \epsilon)$. If V_1 and V_2 define distinct germs of varieties at x , then V_1 and V_2 have a 0-dimensional intersection in $B(x, \epsilon)$. Thus V_1^j and V_2^j also have 0-dimensional intersection in $B(x, \epsilon)$, which contradicts (1.2''). \square

We will sometimes use the notation $V(x, \epsilon)$ for $V(\psi, \epsilon)$; and we will let V_x denote the corresponding germ at x , which is independent of ψ by Lemma 2.6.

We may define

$$(2.4) \quad \tilde{V}_x = \bigcup_{\psi \in \Psi_x} \psi(|\zeta| < R_x).$$

By the proof of Lemma 2.6, there can be no 0-dimensional components of $\psi_1(|\zeta| < R_x) \cap \psi_2(|\zeta| < R_x)$. Thus for $y \in \tilde{V}_x$, there is a unique irreducible germ of a variety, W which is contained in \tilde{V}_x and which contains y . Thus there is a Riemann surface \mathcal{R} and an injective holomorphic mapping $\chi: \mathcal{R} \rightarrow \tilde{V}_x$; this Riemann surface is the normalization of the singularities of \tilde{V}_x (see [Ch, §6]).

PROPOSITION 2.7. *Suppose that f does not preserve volume. If $x \in J^*$ has period n , and if one of the multipliers of Df_x^n has modulus 1, then (\dagger) does not hold.*

Proof. We may assume that $x \in J^*$ is a fixed point of f . If $\mu_1, \mu_2 \in \mathbf{C}$ denote the multipliers of Df_x , then we may suppose that $|\mu_1| < |\mu_2| = 1$. Let us suppose that (\dagger) holds at x , and let $\chi: \mathcal{R} \rightarrow \tilde{V}_x$ be as above. Set $\tilde{x} = \chi^{-1}x$. Then f induces a biholomorphic mapping $F := \chi^{-1} \circ f \circ \chi: \mathcal{R} \rightarrow \mathcal{R}$, and $F(\tilde{x}) = x$. For nonconstant $\psi \in \Psi_x$ we may write $\psi(\zeta) = x + \sum_{m=k}^{\infty} a_m \zeta^m$ with $a_m \in \mathbf{C}^2$ and $a_k \neq 0$. Given $\psi'(\zeta) = x + \sum_{m=k'}^{\infty} a'_m \zeta^m \in \Psi_x$, there exists $\psi \in \Psi_x$ such that

$$\psi' = \tilde{f}(\psi) = f \circ \psi(\lambda_{\psi}^{-1} \zeta) = \lambda_{\psi}^{-k} (Df_x \cdot a_k) \zeta^k + O(\zeta^{k+1}).$$

We conclude that $k' = k$, and $a'_k = \lambda_{\psi}^{-k} (Df_x \cdot a_k)$. Thus a_k is an eigenvector of Df_x , so $a'_k = \lambda_{\psi}^{-k} \mu_j a_k$ for one of the eigenvalues μ_j . Since we may choose ψ such that a_k has maximal length, it follows that $|a'_k| \leq |a_k|$, so $|\mu_j| \geq |\lambda_{\psi}^k| \geq 1$, and so the eigenvalue must be μ_2 .

We may also write $\chi(t) = \sum_{m=k}^{\infty} b_m t^k$ for $b_m \in \mathbf{C}^2$, $b_k \neq 0$. We compute that $F'(\tilde{x}) = \mu_2$. Thus $F: \mathcal{R} \rightarrow \mathcal{R}$ is an automorphism with a fixed point \tilde{x} with multiplier $e^{2\pi i \theta}$. Passing to covering spaces, we may assume that \mathcal{R} is \mathbf{C} or the unit disk. If $\theta \in \mathbf{Q}$, then we may assume that $\mu_2 = 1$, and thus F is the identity. But this is not possible, since this would mean that f is the identity on \tilde{V}_x ; but the fixed points of f are discrete. The other possibility, $\theta \notin \mathbf{Q}$ is also not possible. For in this case it follows from [BS2, Proposition 2] that x is contained in the interior of K^+ , so $x \notin J^*$. \square

We consider the following condition on a point $x \in J^*$:

(\ddagger) Every mapping in Ψ_x is nonconstant.

Note that if $R_x > 1$, then ψ is holomorphic on $\{|\zeta| < R_x\} \supset \{|\zeta| \geq 1\}$, and $\max_{|\zeta| \leq 1} G^+ \circ \psi = 1$. Since $G^+ \circ \psi(0) = 0$, it follows that (\ddagger) holds. The failure of (\ddagger) thus implies that $R_x = 1$ and thus by Proposition 2.2 $\hat{\lambda}(x, n) = 1$ for $n \leq 0$.

LEMMA 2.8. *If (\ddagger) holds, there exist $\epsilon > 0$ and $0 < r < 1$ such that for each $\psi \in \Psi_x$ there exists $\rho \leq r$ such that*

$$\text{dist}(\psi(\zeta), \psi(0)) \geq \epsilon$$

for all $|\zeta| = \rho$. If (\ddagger) holds for all $x \in J^$, the ϵ and r may be chosen to hold for all $x \in J^*$.*

Proof. We expand each $\psi \in \Psi$ in a power series about $\zeta = 0$, $\psi(\zeta) = x + \alpha_1 \zeta + \alpha_2 \zeta^2 + \dots$, with $\alpha_j \in \mathbf{C}^2$. For each j , $\psi \mapsto \alpha_j$ is a continuous mapping from Ψ to \mathbf{C}^2 . Since ψ is not constant, there exist $r_{\psi}, \epsilon_{\psi} > 0$ such that $|\psi(\zeta)| > \epsilon_{\psi}$ for $|\zeta| = r_{\psi}$. This inequality continues to hold in a small neighborhood of ψ inside Ψ . Thus we obtain r and ϵ by the compactness of Ψ . \square

The following shows that if f is quasi-expanding, then each germ V_x is contained in a variety $V(x, \epsilon)$ with uniformly large inner diameter and uniformly bounded area. This is an easy consequence of Lemma 2.8 and the fact that $\text{Area}(\psi(D)) = \int_D |\psi'|^2$.

PROPOSITION 2.9. *If f is quasi-expanding, then there exist $\epsilon > 0$ and $A < \infty$ such that for each $x \in J^*$, $V(x, \epsilon)$ is a (closed) subvariety of $B(x, \epsilon)$, the area of $V(x, \epsilon)$ is bounded by A .*

The following is a strong converse to Proposition 1.5.

THEOREM 2.10. *If f is not quasi-expanding, then there exists a point $x \in J^*$ such that either (\ddagger) fails, or $r_x > 0$. In either case, (1.12) fails.*

Proof. If f is not quasi-expanding, then by Corollary 2.5 there exists $\psi \in \Psi$ such that $|\lambda(\psi, n)| = 1$ for $n \leq 0$. If we set $\psi_n = \tilde{f}^n \psi$ and $m_{\psi_n}(r) = \sup_{|\zeta| < r} G^+ \circ \psi_n(\zeta)$, then $m_{\psi_n}(|\lambda(\psi, n)|r) = d^n m_\psi(r)$. Let ψ_0 be a limit of ψ_{n_j} for some subsequence $n_j \rightarrow -\infty$. It follows that $m_{\psi_0}(1) = 0$. Set $x = \psi_0(0)$. If ψ_0 is constant, then (\ddagger) fails at x .

Otherwise, if ψ_0 is nonconstant, we set $V_0 := \psi_0(\{|\zeta| < 1\})$. Thus V_0 is a connected neighborhood of x in $\tilde{V}_x \cap \{G^+ = 0\}$, where \tilde{V}_x is as in (2.4). Note that $\tilde{V}_x \cap \{G^+ < 1\} \subset J^- \cap \{G^+ < 1\}$ is bounded, and thus $\tilde{V}_x \cap \{G^+ < 1\}$ is Kobayashi hyperbolic. Let $D_K(c)$ denote the disk with center x and radius c in the Kobayashi metric of $\tilde{V}_x \cap \{G^+ < 1\}$. We may choose c small enough that $D_K(c) \subset V_0$. Now choose r small enough that the length of $[0, r]$ with respect to the Kobayashi metric of the unit disk is less than c . It follows that for any $\psi \in \Psi_x$ we have $\psi(\{|\zeta| < 1\}) \subset \tilde{V}_x \cap \{G^+ < 1\}$, and thus $\psi(\{|\zeta| < 1\}) \subset D_K(c) \subset V_0$. Thus $r_x \geq r$. □

3. Area bounds and distortion. In this section we establish a bounded area distortion theorem and use it to give sufficient conditions for quasi-expansion. Recall that if $A \subset \mathbf{C}$ is a doubly connected domain, then A is conformally equivalent to a circular annulus $\{\zeta \in \mathbf{C} : r_1 < |\zeta| < r_2\}$. The *modulus* of this annulus, written $\text{Mod}(A)$, is equal to $\log(r_2/r_1)$. We will use the notation $B_R = B(0, R)$ for the ball centered at the origin in \mathbf{C}^n .

THEOREM 3.1. *Let $D \subset \mathbf{C}$ be a disk, let $0 < R_0 < R_1$ be given, and let $\phi: D \rightarrow B_{R_1}$ be a proper holomorphic map. Let A denote the area of the image $\phi(D)$. The set $\phi^{-1}(B_{R_0})$ is a union of topological disks. Let C be any component of $\phi^{-1}(B_{R_0})$. The set $D - C$ is a topological annulus, and*

$$\text{Mod}(D - C) \geq \frac{\log(R_1/R_0)}{\frac{A}{R_1^2} \left(2 + \frac{1}{\log(R_1/R_0)}\right)}.$$

Proof. The modulus of the annulus $D - C$ is equal to the extremal length of the family of curves that connect the boundary components. We recall the computation of extremal length (see Fuchs [F]). Given a conformal metric $\rho(z)|dz|$

on the annulus, the length of a curve γ is $\text{Length}(\gamma) = \int_{\gamma} |dz|$. We define the extremal length L of the curve family by the formula

$$\frac{1}{L} = \inf_{\rho} \frac{\text{Area}(\rho_0)}{m^2}, \text{ where } \text{Area}(\rho_0) = \int \rho^2(z) dA,$$

and m is the infimum of $\text{Length}(\gamma)$ for all γ in the curve family.

Any particular choice of $\rho = \rho_0$ gives a lower estimate: $L \geq m^2/\text{Area}(\rho_0)$. Let ds be the Euclidean metric on \mathbf{C}^n . Let $r(z) = |z|$ be the radial distance of a point $z \in \mathbf{C}^n$ to the origin, and let ρ_0 be the pullback under ϕ of the metric which is defined as ds/r on $B_{R_1} - B_{R_0}$ and which is zero on B_{R_0} .

We will estimate the minimal length of a curve and the area for the metric ρ_0 . Define $g(v) = \log |v| = \frac{1}{2} \log(v, v)$ for $v \in \mathbf{C}^n$, so that $\nabla g = v/|v|^2$. Let $\gamma(t)$ be a path in $D - C$ with $\gamma(0) \in \partial C$ and $\gamma(1) \in \partial D$.

$$\begin{aligned} \text{Length}(\gamma) &= \int_0^1 \frac{|(\phi \circ \gamma)'(t)|}{|(\phi \circ \gamma)(t)|} dt = \int_0^1 \frac{|(\phi \circ \gamma)'(t)| \cdot |(\phi \circ \gamma)(t)|}{|(\phi \circ \gamma)(t)|^2} dt \\ &\geq \int_0^1 (\phi \circ \gamma)' \cdot \nabla g dt = g(1) - g(0) \\ &= \log |\phi\gamma(1)| - \log |\phi\gamma(0)| = \log(R_1/R_0). \end{aligned}$$

Let $F(r)$ denote the area of $\phi(D) \cap B_r$ with respect to the standard metric on \mathbf{C}^n . By definition, $F(R_1) = A$. The area of $D - C$ with respect to ρ_0 is

$$\text{Area}(\rho_0) = \int_{R_0}^{R_1} \frac{F'(r)}{r^2} dr.$$

Now we integrate by parts and use the property (see [Ch, p. 189]) that $F(r)/r^2$ is nondecreasing in r to obtain

$$\begin{aligned} \int_{R_0}^{R_1} \frac{F'(r)}{r^2} dr &= \left(\frac{F(R_1)}{R_1^2} - \frac{F(R_0)}{R_0^2} \right) - \int_{R_0}^{R_1} F(r) \frac{-2}{r^2} \frac{dr}{r} \\ &= \frac{F(R_1)}{R_1^2} - \frac{F(R_0)}{R_0^2} + 2 \int_{R_0}^{R_1} \frac{F(r)}{r^2} \frac{dr}{r} \\ &\leq \frac{F(R_1)}{R_1^2} + \frac{2F(R_1)}{R_1^2} \log \frac{R_1}{R_0}. \end{aligned}$$

Thus

$$\begin{aligned} \text{Mod}(D - C) = L &\geq \frac{\left(\log \frac{R_1}{R_0}\right)^2}{\frac{A}{R_1^2} + \frac{2A}{R_1^2} \log \frac{R_1}{R_0}} \\ &= \frac{\log \frac{R_1}{R_0}}{\frac{A}{R_1^2} \left(2 + \frac{1}{\log \frac{R_1}{R_0}}\right)} \end{aligned}$$

which is the desired estimate. \square

Theorem 3.1 yields the following *Bounded Area Distortion Theorem*, which is of independent interest. In dimension $n = 1$, the fact that the area is weighted by the multiplicity of the mapping becomes crucial. For $n = 1$, the part of Theorem 3.2 concerning the containment $\{|\zeta| < ar\} \subset D_0 \subset \{|\zeta| < r\}$ is given in [CJY, Lemma 2.2].

THEOREM 3.2. *Let $A < \infty$ and $\chi > 1$ be given. Then there exist $\rho > 0$ and $a > 0$ with the following property: If $\mathcal{D} \subset \mathbf{C}$ is a simply connected domain containing the origin, and if $\phi: \mathcal{D} \rightarrow B_R$ is a proper holomorphic mapping with $\phi(0) = 0$ and $\text{Area}(\phi(\mathcal{D})) \leq A$, then for some r the component D_0 of $\phi^{-1}(B_{\rho R})$ containing the origin satisfies*

$$\{|\zeta| < ar\} \subset D_0 \subset \{|\zeta| < r\} \subset \{|\zeta| < \chi r\} \subset \mathcal{D}.$$

Proof. We define $r > 0$ to be the minimum value for which $D \subset \{|\zeta| < r\}$, and we define $\kappa > 0$ to be the maximum value for which $\{|\zeta| < \kappa r\} \subset \mathcal{D}$. There are points $\zeta_1 \in \partial D$, $|\zeta_1| = r$ and $\zeta_2 \in \partial \mathcal{D}$, $|\zeta_2| = \kappa r$. By Teichmüller’s Theorem [A, Theorem 4–7], the modulus of the annulus $\mathcal{D} - \bar{D}$ is no greater than the modulus of the complement in \mathbf{C} of the segments $[-r, 0]$ and $[\kappa r, +\infty)$. By Theorem 3.1 we have

$$\text{Mod}(\mathbf{C} - ([-1, 0] \cup [\kappa, +\infty))) \geq \frac{\log(R/\rho)}{\frac{A}{R^2} \left(2 + \frac{1}{\log(R/\rho)}\right)}.$$

The quantity on the left-hand side of this inequality has been much studied. The estimate given by equation (4-21) of [A] shows that the modulus is less than $(2\pi)^{-1} \log(16(\kappa + 1))$. Thus if we take ρ sufficiently small then we can obtain $\kappa \geq \chi$.

Now define $a > 0$ as the largest value for which $\{|\zeta| < ar\} \subset D$. Then there is a point $\zeta_0 \in \partial D$ with $|\zeta_0| = ar$. Without loss of generality, we may assume that $\zeta_0 > 0$. By the Cauchy estimate, we have $|\phi'(\zeta)| \leq R/((\kappa - 1)r)$ for $|\zeta| \leq r$. Since $\phi(0) = 0$ and $\phi(\zeta_0) \in \partial B_{\rho R}$, we have

$$\rho R \leq \int_0^{\zeta_0} |\phi'(t)| dt \leq \frac{R}{(\kappa - 1)r} |\zeta_0| = \frac{Ra}{\kappa - 1}.$$

We conclude that $a \geq (\kappa - 1)\rho$, which completes the proof. □

We consider the condition:

(3.1) There exist $\epsilon > 0$ and $A < \infty$ such that for all $x \in S$,
 $V(x, \epsilon)$ is closed in $B(x, \epsilon)$, and $\text{Area}(V(x, \epsilon)) < A$.

If (3.1) holds, then by Bishop’s Theorem (see [Ch, p. 205]) the family $\{V(x, \epsilon) : x \in S\}$ is pre-compact in the Hausdorff topology. By Lemma 2.8, there is a unique extension to a family of varieties $\{V(x, \epsilon) : x \in J^*\}$, with $V(x, \epsilon) \subset J^-$. We also consider the related condition, in which S is replaced by J^* :

$$(3.1') \quad \text{There exist } \epsilon > 0 \text{ and } A < \infty \text{ such that for all } x \in J^*, \\ V(x, \epsilon) \text{ is closed in } B(x, \epsilon), \text{ and } \text{Area}(V(x, \epsilon)) < A.$$

Clearly (3.1') \Rightarrow (3.1). By Proposition 2.9, conditions (3.1) and (3.1') hold if f is quasi-expanding.

THEOREM 3.3. (3.1) \Rightarrow ((\ddagger) holds for all $x \in J^*$) \Rightarrow (3.1').

Proof. Suppose that (3.1) holds. For $\chi > 1$, let ρ and a be the constants from Theorem 3.2. We may assume that $\epsilon > 0$ is small enough that $\max_{\bar{B}(x, \epsilon)} G^+ \leq 1$ for all $x \in J^*$. For $x \in S$ we let $\psi_x \in \psi_S$ be the corresponding immersion. Let \mathcal{D} (respectively, D_0) denote the connected component of $\psi_x^{-1}(B(x, \epsilon))$ (respectively, $\psi_x^{-1}(B(x, \rho\epsilon))$) containing the origin. Since $G^+ \circ \psi_x \leq 1$ on $\{|\zeta| < r\chi\} \subset \mathcal{D}$ it follows that $r\chi \leq 1$, so $r \leq 1/\chi$. We note that $\text{dist}(\psi_x(\zeta), x) = \text{dist}(\psi_x(\zeta), \psi_x(0)) = \rho\epsilon$ for all $\zeta \in \partial D_0$, and that $\partial D_0 \subset \{|\zeta| \leq 1/\chi\}$. It follows that if a sequence of mappings ψ_{x_j} converges to a map ψ , then there will be a point ζ with $|\zeta| \leq 1/\chi$ and $\text{dist}(\psi(\zeta), \psi(0)) = \rho\epsilon$, and so ψ cannot be constant. Thus (\ddagger) holds.

Next let us suppose that (\ddagger) holds. We have already observed that with ϵ as in Lemma 2.8, $V(x, \epsilon)$ is closed in $B(x, \epsilon)$. By the compactness of Ψ , $C_0 = \sup_{\psi} \sup_{|\zeta| \leq r} |\psi'(\zeta)| < \infty$, so

$$\text{Area}(V(x, \epsilon)) \leq \int_{|\zeta| \leq r} |\psi'(\zeta)|^2 \leq \pi r^2 C_0^2,$$

so (3.1') holds. □

The germ V_x being contained in K is equivalent to $G^+ \circ \psi(\zeta) = 0$ for $|\zeta| < r$; by Proposition 1.5 this prevents quasi-expansion. The condition that no germ V_x is contained in $K^+ = \{G^+ = 0\}$ may be viewed as a weak form of transversality between V_x and K^+ .

THEOREM 3.4. *If (3.1) holds, and if no germ $V_x, x \in J^*$, is contained in K , then f is quasi-expanding.*

Proof. Let $\epsilon > 0$ and $A < \infty$ be as in (3.1). For $\chi > 1$, let ρ be the constant in Theorem 3.2, corresponding to the number A . By the continuity of G^+ , we may shrink ϵ so that

$$\max_{x \in J^*} \max_{\bar{B}(x, \epsilon)} G^+ \leq 1.$$

We set

$$c_0 := \min_{x \in J^*} \max_{V(x, \rho\epsilon)} G^+.$$

We claim that $c_0 > 0$. By Theorem 3.3, $\{V_x, x \in J^*\}$ is a compact family of varieties. If $c_0 = 0$, then by compactness we would have $G^+ = 0$ on $V(x, \rho\epsilon)$ for some $x \in J^*$. This germ V_x would be contained in K , contradicting our hypothesis. Thus $c_0 > 0$, and we choose n such that $d^n c_0 \geq 1$.

For $x \in S$, let \mathcal{D} (respectively D_0) be the connected component of $\psi^{-1}B(x, \epsilon)$ (respectively $\psi^{-1}B(x, \rho\epsilon)$) containing the origin. Thus

$$D_0 \subset \{|\zeta| < r\} \subset \{|\zeta| < r\chi\} \subset \mathcal{D}.$$

Since $G^+ \circ \psi_x \leq 1$ on \mathcal{D} , it follows that $r\chi \leq 1$. We also have

$$c_0 \leq \max_{\zeta \in D_0} G^+ \leq \max_{|\zeta| \leq r} G^+.$$

Now applying f^n , the set V_x is mapped to $V_{f^n x}$, which is uniformized by ψ_{x_n} . It follows that

$$\max_{|\zeta| \leq |\lambda(x, n)|r} G^+ \circ \psi_{x_n} \geq c_0 d^n \geq 1.$$

By the normalization (1.3) on ψ_{x_n} it follows that $|\lambda(x, n)|r \geq 1$. We conclude that

$$|\lambda(x, n)|r \geq 1 \geq \chi r,$$

or $|\lambda(x, n)| \geq \chi > 1$. By Theorem 1.2, then, f^n is quasi-expanding. Thus by Proposition 1.3, f is quasi-expanding. \square

The following two Corollaries are just restatements of Proposition 2.3 and Theorem 2.8 in terms of the families ψ_S given as examples at the end of Section 1.

COROLLARY 3.5. *A necessary and sufficient condition for f to be quasi-expanding is that there exist $\epsilon > 0$ and $A < \infty$ such that for each $\delta > 0$ there is an $\eta > 0$ such that for each saddle point p we have: $W_\epsilon^u(p)$ is closed in $B(p, \epsilon)$, $\text{Area}(W_\epsilon^u(p)) \leq A$, and $\sup_{W_\delta^u(p)} G^+ \geq \eta$.*

COROLLARY 3.6. *A necessary and sufficient condition for f to be quasi-expanding is that there exist $\epsilon > 0$, $A < \infty$ and saddle points p, q such that for each $\delta > 0$ there is an $\eta > 0$ such that $W_\epsilon^u(z)$ is closed in $B(z, \epsilon)$, $\text{Area}(W_\epsilon^u(z)) \leq A$, and $\sup_{W_\delta^u(z)} G^+ \geq \eta$ for all $z \in W^u(p) \cap W^s(q)$.*

COROLLARY 3.7. *The condition that f is quasi-expanding is independent of the family ψ_S .*

A quasi-expanding mapping has a certain uniform contraction along backward orbits, at finite scale.

THEOREM 3.8. *If f is quasi-expanding, then there exist $\epsilon > 0$ and $\theta < 1$ such that for all $x \in J^*$ and $n \geq 0$, $\text{diam}(f^{-n}V(x, \epsilon)) \leq \theta^n$ and $\text{Area}(f^{-n}V(x, \epsilon)) \leq \theta^n$.*

Proof. Let $A < \infty$ and $\epsilon > 0$ be as in Proposition 2.9. Let c be the maximum of G^+ in an ϵ -neighborhood of J^* . Let $M(r)$ be as in Theorem 1.2, and let r_c be such that $M(r_c) = c$. We note that by choosing ϵ sufficiently small, we can make c arbitrarily close to zero. By the continuity of $M(r)$, then, the constant r_c may be taken arbitrarily close to zero.

Let a and ρ be as in Theorem 3.2. For $x \in J^*$, let \mathcal{D}_x denote the connected component of $\psi_x^{-1}V(x, \epsilon)$ containing the origin. It follows from Theorem 3.2 that there exists r_x such that

$$\{|\zeta| < ar_x\} \subset \psi_x^{-1}V(x, \rho\epsilon) \subset \{|\zeta| < r_x\}.$$

It is evident that $ar_x \leq r_c$. Define

$$M := \sup_{\psi \in \Psi} \sup_{|\zeta| < a^{-1}r_c} |\psi'(\zeta)| < \infty$$

which is finite by the compactness of Ψ . By the transformation formula (1.4), and by (4) of Theorem 1.2, we have

$$f^{-n}V(x, \rho\epsilon) \subset f^{-n}\psi_x(|\zeta| < a^{-1}r_c) \subset \psi_{f^{-n}x}(|\zeta| < \kappa^{-n}a^{-1}r_c).$$

Thus we obtain the estimates

$$\begin{aligned} \text{Area}(f^{-n}V(x, \rho\epsilon)) &\leq \int_{|\zeta| < \kappa^{-n}a^{-1}r_c} |\psi'_{f^{-n}x}(\zeta)|^2 \\ &\leq \pi(\kappa^{-n}a^{-1}r_c)^2 M^2. \end{aligned}$$

and

$$\begin{aligned} \text{diam}_{\mathbb{C}^2}(f^{-n}V(x, \rho\epsilon)) &\leq (\max |\psi'|) \text{diam}\{|\zeta| < \kappa^{-n}a^{-1}r_c\} \\ &\leq M \cdot 2\kappa^{-n}a^{-1}r_c. \end{aligned}$$

Finally, it suffices to take r_c sufficiently small that $2Ma^{-1}r_c < 1$. □

PROPOSITION 3.9. *If f is uniformly hyperbolic on J^* , then f and f^{-1} are quasi-expanding.*

Proof. Let $\mathcal{W}^u = \{W^u(x) : x \in J^*\}$ denote the lamination defined by the unstable manifolds through points of J^* . Since \mathcal{W}^u contains the sets $V(x, \epsilon)$, it

follows that (3.1') holds. For $x \in J^*$ let $\|\cdot\|_x^\#$ denote the metric on the tangent space E_x^u , as well as the distance induced on $W^u(x)$ by $\|\cdot\|_x^\#$. For $x \in J^*$, let $0 \leq r(x) \leq \infty$ denote the largest number such that the $\|\cdot\|_x^\#$ -disk $D(x, r(x)) \subset W^u(x)$ is contained in $\{G^+ = 0\}$. Since $|\lambda_\psi| \geq 1$, we have $r(fx) \geq r(x)$.

By [BS7, §5], $x \mapsto \|\cdot\|_x^\#$ varies continuously. It follows that $J^* \ni x \mapsto r(x)$ is upper semicontinuous. We will show that $r(x) = 0$. Suppose, to the contrary, that $R := \sup_{x \in J^*} r(x) > 0$. By upper semicontinuity there exists $x_0 \in J^*$ with $r(x_0) = R$. If $R = \infty$, it follows that $W^u(x_0)$ is conformally equivalent to \mathbf{C} , and that $W^u(x_0) \subset K$, which is a contradiction. If $R < \infty$, then we let X denote the ω -limit set of x_0 , i.e., the set of limits of sequences $\{f^{n_j}x_0\}$, $n_j \rightarrow \infty$. Clearly X is f -invariant and compact, so it is a hyperbolic set for f . Since r is upper semicontinuous, we have $r(x) = R$ for all $x \in X$. Thus for $x_0 \in X$

$$W^u(x_0) \supset \bigcup_{n \geq 0} f^n(D(f^{-n}x_0, r(f^{-n}x_0))) = \bigcup_{n \geq 0} f^n(D(f^{-n}x_0, R)).$$

Since $\|\cdot\|^\#$ is comparable to euclidean distance, there exists $r_0 > 0$ such that $D(f^{-n}x_0, R)$ contains a disk with Euclidean radius r_0 in $W^u(f^{-n}x_0)$. It follows, then, as in [BS1] that $W^u(x_0) \subset \{G^+ = 0\}$ and is conformally equivalent to \mathbf{C} , which is a contradiction. Thus we conclude that $r = 0$ on J^* . It now follows from Theorem 3.4 that f is quasi-expanding. The argument for f^{-1} is the same. \square

PROPOSITION 3.10. *Suppose f is quasi-expanding. Then there exist $\epsilon > 0$ and $N < \infty$ such that $f^n V(x, \epsilon) \supset V(f^n x, \epsilon)$ for $x \in J^*$ and $n \geq N$.*

Proof. By Lemma 2.8 and Theorem 3.2 there exist $\epsilon > 0$ and $L < \infty$ such that

$$\psi_x(\{\zeta \in \mathbf{C} : |\zeta| < 1/L\}) \subset V(x, \epsilon) \subset \psi_x(\{\zeta \in \mathbf{C} : |\zeta| < L\})$$

for each $\psi_x \in \Psi_x$. Let $\kappa > 1$ be as in Theorem 1.2, and choose N such that $\kappa^N > L^2$. It follows, then that N has the desired property. \square

4. Equivalence of families of metrics. In this section we show (Theorem 4.8) that real mappings of maximal entropy are quasi-expanding. By Theorem 1.2, quasi-expansion is equivalent to uniform expansion with respect to the metric $\|\cdot\|^\#$. We introduce a family of metrics $\|\cdot\|^{(L)}$, and we show that this metric is uniformly expanded by real mappings of maximal entropy. Then we show that this metric is equivalent to $\|\cdot\|^\#$, from which we obtain Theorem 4.8. We also give an alternate proof of Proposition 3.9, which shows that (uniformly) hyperbolic mappings are quasi-expanding (Corollary 4.13).

We will compare several norms on the unstable tangent space E_x^u . By $\|\cdot\|^e$ we denote the norm on E_x^u induced by the euclidean metric on \mathbf{C}^2 . If $\|\cdot\|$ denotes an complex affine invariant metric on E_x^u , then $\|\cdot\|$ is determined by its value at the

origin. Since E_x^u has complex dimension 1, it follows that all such affine metrics are real multiples of each other, i.e., there exists $\alpha = \alpha(x)$ such that $\|\cdot\| = \alpha \|\cdot\|^\epsilon$.

Now we define $\|\cdot\|^{(L)}$. For $0 < L < \infty$, we let $D^{(L)} = D_x^{(L)}$ denote the connected component of $\{\zeta \in \mathbf{C} : G^+ \circ \psi_x(\zeta) < L\}$ which contains the origin. Since $G^+ \circ \psi_x$ is subharmonic on \mathbf{C} , it follows from the maximum principle that $D^{(L)}$ is simply connected. We will use ψ_x to transport the Poincaré metric of $D^{(L)}$ at 0 to E_x^u . That is, let ds_P denote the Poincaré metric of $D^{(L)}$ at $\zeta = 0$, and for any $v \in E_x^u$ we define

$$\|v\|_x^{(L)} := ds_P((d\psi_x)^{-1}v).$$

One way to define the Poincaré metric is to let $B_1 = \{\zeta \in \mathbf{C} : |\zeta| < 1\}$ and let $\chi_x^{(L)}: B_1 \rightarrow D_x^{(L)}$ be the conformal equivalence such that $\chi_x^{(L)}(0) = 0$. Then if 1 denotes the tangent vector with unit length in the euclidean metric, we have $ds_P(1) = |\chi_x^{(L)}(0)'|^{-1}$, so that

$$(4.1) \quad \|v\|_x^{(L)} = |v/\chi_x^{(L)}(0)'|.$$

If $L \leq L'$, then $D^{(L)} \subset D^{(L')}$, and so the Poincaré metrics of the two domains have the reverse inequality, so that $\|\cdot\|^{(L)} \geq \|\cdot\|^{(L')}$. By the identity $G^+ \circ f = d \cdot G^+$ it follows that f maps the set $D_x^{(L)}$ to the set $D_{f_x}^{(dL)}$. Thus for $v \in E_x^u$ we have

$$(4.2) \quad \|v\|_x^{(L)} = \|Df_x v\|_{f_x}^{(dL)} < \|Df_x v\|_{f_x}^{(L)}.$$

If $\|\cdot\|_x^*$ and $\|\cdot\|_x^\diamond$ are families of affine metrics for $x \in S$, we define the comparison function a_\diamond^* : $S \rightarrow \mathbf{R}$, which is given by $a_\diamond^*(x) := \log(\|v\|_x^*/\|v\|_x^\diamond)$ for any nonzero $v \in E_x^u$. We say that $\|\cdot\|^*$ is *equivalent* to $\|\cdot\|^\diamond$ if $a_\diamond^*(x)$ is a bounded function of $x \in S$. Note that this is an equivalence relation.

Let us compare $\|\cdot\|^\#$ and $\|\cdot\|^{(1)}$. Recall from the definition of $\|\cdot\|_x^\#$ that the unit disk in \mathbf{C} is the largest disk centered at the origin which is contained in $\{G^+ \circ \psi_x < 1\}$, i.e., $D^{(1)}$ contains the disk $\{\zeta \in \mathbf{C} : |\zeta| < 1\}$, and there is a point $\zeta_0 \in \partial D^{(1)}$ with $|\zeta_0| = 1$. Since $G^+ \circ \psi_x$ is subharmonic on \mathbf{C} , it follows that $D^{(1)}$ is simply connected. As above, we let $\chi = \chi^{(1)}: \{|\zeta| < 1\} \rightarrow D^{(1)}$ be a conformal equivalence such that $\chi(0) = 0$. It follows that the Poincaré metric ds_P satisfies: $ds_P(1) = |\chi'(0)|$. By the Koebe 1/4-Theorem, we have $\frac{1}{4} \leq |\chi'(0)| \leq 1$. It follows from (1.9) and (4.1) that

$$(4.3) \quad \|\cdot\|_x^\# \leq \|\cdot\|_x^{(1)} \leq 4\|\cdot\|_x^\#.$$

Thus

$$-\log 4 \leq a_{(1)}^\# \leq 0,$$

and so these metrics are equivalent.

When $L < L'$, we have the map

$$(4.4) \quad \rho := (\chi_x^{(L')})^{-1} \circ \chi_x^{(L)}: B_1 \rightarrow B_1.$$

From the fact that $D_x^{(L)}$ is a strict subset of $D_x^{(L')}$, it follows that $|\rho'(0)| < 1$. Thus by the definitions above

$$(4.5) \quad a_{(L)}^{(L')} = -\log |\rho'(0)| > 0,$$

which corresponds to the earlier observation that $\|\cdot\|_x^{(L)} < \|\cdot\|_x^{(L')}$ for all x . A lower bound on $a_{(L)}^{(L')}$ is equivalent to a lower bound on $|\rho'(0)|$, which is equivalent to the existence of $0 < r < 1$ such that $\{|z| < r\} \subset \rho(B_1)$ for all $x \in S$.

LEMMA 4.1. *There exists $0 < L_0 < \infty$, (depending on f), such that for $L_0 < L' < \infty$, $\|\cdot\|^{(L_0)}$ is equivalent to $\|\cdot\|^{(L')}$.*

Proof. We let π denote the coordinate projection onto the second coordinate axis. It follows that the restrictions of $|\pi|$ and G^+ to J^- are proper exhaustions of J^- . Let us choose C_1 such that

$$\{G^+ = 0\} \cap J^- \subset \{|\pi| < C_1\}.$$

For L_0 sufficiently large, there exists $C_2 > C_1$ such that

$$\{G^+ > L\} \subset \{|\pi| > C_2\}.$$

Finally, for $L' < \infty$ we may choose $C_3 > C_2$ sufficiently large that

$$\{G^+ < L'\} \subset \{|\pi| < C_3\}.$$

Let s denote the distance between $\{|z| = C_1\}$ and $\{|z| = C_2\}$, measured with respect to the Poincaré metric on $\{|z| < C_3\}$. Let $0 < r < 1$ be chosen so that the Poincaré distance from 0 to r inside B_1 is equal to s . We will show that $\rho(B_1)$ contains the disk of radius r about the origin. For if $|z_0| < r$, then the Poincaré distance between 0 to z_0 is less than s . We consider $A := \pi \circ \psi_x \circ (\chi^{(L')})^{-1}(0)$ and $B := \pi \circ \psi_x \circ (\chi^{(L')})^{-1}(z_0)$. Since $0 \in J \subset J^- \cap \{G^+ = 0\}$, it follows that $|A| < C_1$. By the definition of $D^{(L')}$ and C_3 , it follows that

$$\pi \circ \psi_x \circ (\chi^{(L')})^{-1}(B_1) \subset \{|z| < C_3\}.$$

Thus $\pi \circ \psi_x \circ (\chi^{(L')})^{-1}$, as a mapping from B_1 to the disk $\{|z| < C_3\}$ decreases the respective Poincaré metrics. Thus the distance between the points A and B is less than s , so we conclude that B is contained in the disk $\{|z| < C_2\}$. By

the definition of C_2 , then, it follows that $G^+(\psi_x \circ (\chi^{(L')})^{-1}(z_0)) < L$. Thus we conclude that z_0 is in the range of ρ , which gives the desired lower estimate. \square

Given a family of metrics $\|\cdot\|$ the effect of the differential Df is measured by the function $c(x, n) := \log(\|Df_x^n v\|_{f^n x} / \|v\|_x)$, where v is a nonzero element of E_x^u . The chain rule gives the following cocycle condition for c :

$$(4.6) \quad c(x, n+m) = c(x, n) + c(f^n x, m).$$

Let $c^\# = c^\#(\cdot, 1)$ denote the cocycle corresponding to the metric $\|\cdot\|^\#$. Then we have $c^\#(x, 1) = \log|\lambda_x|$, so $c^\# > 0$.

The cocycle $c^{(L)}$ corresponding to the metric $\|\cdot\|^{(L)}$ satisfies

$$(4.7) \quad c^{(L)}(x, 1) = \log \frac{\|Df_x v\|_{f x}^{(L)}}{\|v\|_x^{(L)}} = \log \frac{\|v\|_x^{(L/d)}}{\|v\|_x^{(L)}} = a_{(L)}^{(L/d)}(x).$$

By (4.5) we have $c^{(L)} > 0$. Note that a priori $c^\#$ and $c^{(L)}$ are not bounded below by strictly positive numbers.

LEMMA 4.2. *For all $0 < L, L' < \infty$, the cocycle $c^{(L)}$ is bounded, and thus $\|\cdot\|^{(L)}$ is equivalent to $\|\cdot\|^{(L')}$.*

Proof. For a point $x_0 \in S$ and $v_0 \in E_{x_0}^u$, we set $x_j = f^j x_0$ and $v_j = Df^j v_0$. Applying (4.2), we have

$$\|Df v_n\|_{x_{n+1}}^{(L)} = \|v_n\|_{x_n}^{(d^{-1}L)} = \|Df v_{n-1}\|_{x_n}^{(d^{-1}L)} = \dots = \|Df v_0\|_{x_1}^{(d^{-n}L)}.$$

This gives

$$c^{(L)}(x_{n+1}, 1) = \log \frac{\|Df v_n\|_{x_{n+1}}^{(L)}}{\|v_n\|_{x_n}^{(L)}} = \dots = \log \frac{\|Df v_0\|_{x_1}^{(d^{-n}L)}}{\|v_0\|_{x_0}^{(d^{-n}L)}} = c^{(d^{-n}L)}(x_0, 1).$$

By Lemma 4.1 and the monotonicity of $\|\cdot\|^{(L)}$, there exists $\kappa < \infty$ such that $0 \leq a_{L_1}^{L_0} \leq \kappa$ for all $L_0 \leq L_1 \leq L_2$. This gives $0 \leq c^{(L_1)}(x, 1) \leq \kappa$ for all $x \in S$. Thus $0 \leq c^{(d^{-n}L_1)}(x, 1) \leq \kappa$ for all $x \in S$.

Now choose n such that $L < L' \leq d^n L$. It follows that

$$0 \leq a_{(L')}^{(L)} \leq a_{(d^n L)}^{(L)} = a_{(d^{n-1}L)}^{(dL)} + a_{(d^{n-2}L)}^{(d^{n-1}L)} + \dots + a_{(dL)}^{(L)} = c^{(d^n L)} + \dots + c^{(dL)} \leq n\kappa,$$

which gives the equivalence between the metrics. \square

Given two families of metrics $\|\cdot\|^\star$ and $\|\cdot\|^\diamond$, the corresponding cocycles are related by the coboundary equation:

$$c^\star(x, 1) - c^\diamond(x, 1) = a_\diamond^\star(fx) - a_\diamond^\star(x).$$

We say that two cocycles c^\star and c^\diamond are *equivalent* if they satisfy the coboundary equation

$$c^\star(x, 1) - c^\diamond(x, 1) = \alpha(fx) - \alpha(x)$$

for some function $\alpha: S \rightarrow \mathbf{R}$ which is bounded. With these definitions, equivalent families of metrics produce equivalent cocycles. Indeed the above equation can be solved with the bounded function a_\diamond^\star for α .

LEMMA 4.3. *A cocycle which is equivalent to a bounded cocycle is a bounded cocycle.*

Proof. If c^\star and c^\diamond are equivalent, then $c^\star(x, 1) - c^\diamond(x, 1) = \alpha(fx) - \alpha(x)$ for some bounded function α . If c^\diamond is bounded, then so is $c^\star(x, 1) = \alpha(fx) - \alpha(x) + c^\diamond(x, 1)$. □

COROLLARY 4.4. *The cocycle $c^\#$ is bounded, i.e. there exists $\chi < \infty$ such that $|\lambda_x| < \chi$ for all $x \in S$.*

Proof. By Lemma 4.2, the cocycle $c^{(1)}$ is bounded. And by (4.3) $\|\cdot\|^\#$ is equivalent to $\|\cdot\|^{(1)}$. By Lemma 4.3 it follows that $c^\#(x, 1) = \log |\lambda_x|$ is bounded. □

Let us now discuss the sense in which the metrics $\|\cdot\|^{(L)}$ and $\|\cdot\|^\#$ are “canonical.” They are determined by the complex structure of \mathbf{C}^2 and the choice of Green function G^+ . If \tilde{G}^+ is another Green function, then it is a consequence of [FS, Theorem 7.2] that there is a real number $t > 0$ such that $\tilde{G}^+ = t^{-1}G^+$. If we substitute \tilde{G}^+ for G^+ in the definition of $\|\cdot\|^{(1)}$, then we obtain the metric $\|\cdot\|^{(t)}$, which is equivalent to $\|\cdot\|^{(1)}$ by Lemma 4.2. Next let us substitute \tilde{G}^+ for G^+ in the normalization equation (1.3). By $\tilde{\psi}_x$ we denote the uniformizing function with this new normalization, and we see that condition (1.3) may be restated in terms of the original Green function as

$$(4.8) \quad \tilde{\psi}_x(0) = x, \quad \max_{|\zeta| \leq 1} G^+ \tilde{\psi}_x(\zeta) = t.$$

In analogy with (1.9), we may define the norm

$$\|v\|_x^\# := \left| \frac{v}{\tilde{\psi}'_x(0)} \right|$$

for $x \in S$ and $v \in E_x^u$.

THEOREM 4.5. *The metrics $\|\cdot\|^\#$ and $\|\cdot\|^{\bar{\#}}$ are equivalent.*

Proof. The connection between (1.3) and (4.8) is that there is a real number τ_x such that a uniformization ψ_x is normalized according to (1.3) if and only if $\tilde{\psi}_x(\zeta) := \psi_x(\tau_x\zeta)$ is normalized according to (4.8). The comparison function between these two norms is thus

$$a_{\bar{\#}}^\# = \log \tau_x.$$

We suppose that $t \geq 1$; the opposite case $t \leq 1$ may be treated in an analogous fashion. If $t \geq 1$, then it follows that $\tau_x \geq 1$ for all $x \in S$, and thus $a_{\bar{\#}}^\# \geq 0$. It suffices to show that $a_{\bar{\#}}^\#$ is bounded above, or equivalently, that τ_x is bounded above.

Let us choose k such that $t \leq d^k$. It follows from (4.8) that

$$\begin{aligned} 1 &\geq d^{-k} \max_{|\zeta| \leq 1} G^+ \circ \tilde{\psi}_x(\zeta) = \max_{|\zeta| \leq 1} G^+ \circ f^{-k} \circ \tilde{\psi}_x(\zeta) = \max_{|\zeta| \leq 1} G^+ \circ f^{-k} \circ \psi_x(\tau_x\zeta) \\ &= \max_{|\zeta| \leq 1} G^+ \circ \psi_{f^{-k}x}(\tau_x \lambda_{f^{-1}x}^{-1} \cdots \lambda_{f^{-k}x}^{-1} \zeta). \end{aligned}$$

We conclude that $|\tau_x \lambda_{f^{-1}x}^{-1} \cdots \lambda_{f^{-k}x}^{-1}| \leq 1$. So by Corollary 4.4, we have $\tau_x \leq \chi^k$, so τ_x is bounded independently of x . \square

A cocycle c is said to be *eventually positive* if for some $n > 0$ and some $K > 0$ we have $c(x, n) \geq K$ for all $x \in S$. We first observe:

LEMMA 4.6. *A cocycle which is boundedly cohomologous to an eventually positive cocycle is eventually positive.*

Proof. If $\|\cdot\|^\star$ is eventually positive, then $c^\star(x, n) \geq K$ for $n \geq k$. If $\|\cdot\|^\diamond$ is equivalent, then

$$c^\diamond(x, 1) - c^\star(x, 1) = a(fx) - a(x)$$

for a comparison function a with $|a| \leq C$ for some C . Now

$$c^\diamond(x, n) - c^\star(x, n) = a(f^n x) - a(x).$$

If $nK > 2C$, then

$$c^\diamond(x, nk) = c^\star(x, nk) + a(f^{nk}x) - a(x) \geq nK - 2C > 0. \quad \square$$

A cocycle is *immediately positive* if $c(x, 1) \geq K > 0$. We recall that one of the equivalent conditions in the definition of quasi-expanding is that the cocycle $c^\#$ corresponding to the metric $\|\cdot\|^\#$ is immediately positive. By Proposition 1.3

and condition (4) of Theorem 1.2, it follows that $c^\#$ is eventually positive if and only if it is immediately positive.

We note that the definition of quasi-expansion in terms of the normalization (1.3) is equivalent to the definition with the normalization (4.8).

THEOREM 4.7. *The family $\tilde{\psi}_S := \{\tilde{\psi}_x : x \in S\}$, normalized according to (4.8), is normal if and only if ψ_S is normal.*

Proof. The proofs of Proposition 1.3 and Theorem 1.2 apply to the cocycle $c^\#$, and so $c^\#$ is immediately positive if and only if it is eventually positive. By Theorem 4.5, $c^\#$ and $\tilde{c}^\#$ are boundedly cohomologous. Thus $c^\#$ is immediately positive if and only if $\tilde{c}^\#$ is immediately positive. By Theorem 1.2, these conditions are equivalent to the normality of ψ_S and $\tilde{\psi}_S$. This proves the Theorem. \square

Now we consider mappings f which are real. This means that the real subspace \mathbf{R}^2 is invariant under f , or in terms of coordinates, f commutes with complex conjugation, i.e., $f(\bar{x}, \bar{y}) = \bar{f}(x, y)$. We let f_R denote the restriction of f to \mathbf{R}^2 . We will say that f is a real mapping with maximal entropy if the real restriction $f_{\mathbf{R}^2}$ has entropy equal to $\log d$. Several results from [BLS] apply to real mappings with maximal entropy. In this case it follows that $J \subset \mathbf{R}^2$, that $J = J^*$, and the periodic points are dense in J . Thus, if p is a (real) periodic point, we may further normalize the uniformizing mapping $\psi_p : \mathbf{C} \rightarrow W^u(p)$ so that $\psi_p(\mathbf{R}) \subset \mathbf{R}^2$. In this case, it follows that $\psi_p(\mathbf{C}) \cap J \subset \mathbf{R}^2$, and thus $\psi_p^{-1}(J) \subset \mathbf{R}$.

THEOREM 4.8. *If f is a real mapping of maximal entropy, then the cocycle corresponding to the metric $\|\cdot\|^{(L)}$ satisfies $c^{(L)}(x, 1) \geq \log d$. Further, f and f^{-1} are both quasi-expanding.*

Proof. We observed above that if f is a real mapping of maximal entropy, then for each saddle point $\psi_x^{-1}(J) \subset \mathbf{R}$. Thus by Proposition 4.9 below, $c^{(L)}$ is a positive cocycle. Since $\|\cdot\|^{(L)}$ is equivalent to $\|\cdot\|^\#$ it follows from Lemma 4.6 that $c^\#$ is eventually positive. By (4) of Theorem 1.2, some iterate f^N is quasi-expanding. By Proposition 1.3, then, f itself is quasi-expanding. The argument for f^{-1} is similar. \square

PROPOSITION 4.9. *If $x \in S$ is such that $\psi_x^{-1}J$ is contained in a straight line in \mathbf{C} , then $c^{(L)}(x, 1) \geq \log d > 1$. If, in addition, $J \cap W^u(x)$ is not connected, then we have $c^{(L)}(x, 1) > \log d$.*

Proof. Without loss of generality, we may assume that the line is $\mathbf{R} \subset \mathbf{C}$. We will estimate $c^{(L)}$ as in (4.7). To do this, we let h^+ denote the unique continuous function on $D^{(L)}$ with the following properties: $0 \leq h^+ < L$, $h^+ = 0$ on $D^{(L)} \cap \mathbf{R}$, h^+ is harmonic on $D^{(L)} - \mathbf{R}$, and h^+ takes the boundary limit L at all points of $(\partial D^{(L)}) - \mathbf{R}$. Since $\psi_x^{-1}J \subset \mathbf{R}$, it follows from the maximum principle that $h^+ \leq G^+ \circ \psi_x$ on $D^{(L)}$. Thus $D^+ := \{h^+ < L/d\} \supset D^{(L/d)}$. Let $\chi^+ : B_1 \rightarrow D^+$

denote the conformal mapping such that $\chi^+(0) = 0$ and $\chi^+(0)' > 0$. If we set $\rho^+ := \chi^{(L)} \circ (\chi^+)^{-1}: B_1 \rightarrow B_1$, then as in (4.5), we have the estimate

$$c^{(L)} = \log |\rho'(0)| \geq \log |\rho^+(0)'|.$$

We will show that $\rho^+(0)' = 1/d$, which gives $c^{(L)} \geq \log d$. We note that since f is real, the set $D^{(L)}$ is invariant under complex conjugation, and thus ρ^+ commutes with conjugation. Thus the real function $h^+ \circ \rho^+$ is invariant under complex conjugation. Further, $h^+ \circ \rho^+$ has the properties of being equal to zero on the axis $(-1, 1)$, harmonic on $B_1 - (-1, 1)$, and taking boundary values L on the nonreal points of ∂B_1 . Let φ denote the conformal mapping from B_1 to the strip $\{\zeta \in \mathbf{C} : -1 < \Im(\zeta) < 1\}$ such that the upper/lower portion of ∂B_1 is taken to $\{\Im(\zeta) = \pm 1\}$. It follows that $h^+ \circ \rho^+ = L|\Im(\varphi)|$ for some $L > 0$. The image of ρ^+ is given by $\rho^+(B_1) = \{h^+ \circ \rho^+ < L/d\}$. Thus ρ^+ is given by $\varphi^{-1} \circ g_d \circ \varphi$, where $g_d(z) = z/d$. We may assume that $\varphi(0) = 0$, so it follows from the fact that $g_d' = 1/d$ that $\rho^+(0)' = 1/d$.

If $J \cap W^u(x)$ is not connected, then $h^+ < G^+ \circ \psi_x$ on $D^{(L)}$ because $\{h^+ = 0\} = \psi_x^{-1}(J) \neq \{G^+ \circ \psi_x = 0\} = \mathbf{R}$. Thus $c^{(L)} = -\log |\rho'(0)| > -\log |\rho^+(0)'| = d$. \square

Next we give an improved estimate for one-sided points, which play an important role in [BS].

PROPOSITION 4.10. *If $x \in S$ and $\psi_x^{-1}J$ is contained in a half-line, then $c^{(L)}(x, 1) \geq 2 \log d$. If, in addition, $\psi_x^{-1}J$ is not connected, then $c^{(L)}(x, 1) > 2 \log d$.*

Proof. Without loss of generality, we may assume that $\psi_x^{-1}J$ contains the origin and is contained in the positive half-line $[0, \infty)$. The proof now proceeds along the lines of the proof of Proposition 4.9 with the modification that the function $|\Im(\zeta)|$ is replaced by $|\Im(\sqrt{\zeta})|$. Let $S(t) = \{\zeta \in \mathbf{C} : |\Im(\sqrt{\zeta})| < t\}$. We let φ denote the conformal mapping from B_1 to the set $S(1)$. The factor of 2 enters because d^2 is the multiplier which maps $S(L/d)$ to $S(L)$. \square

An affine metric on \mathbf{C}_x induces a distance function on $W^u(x)$ via the mapping $\psi_x: \mathbf{C}_x \rightarrow W^u(x)$. The metric $\|\cdot\|^\#$ induces the distance $dist^\#(\psi_x(\zeta_1), \psi_x(\zeta_2)) = |\zeta_1 - \zeta_2|$. Any other metric is of the form $\|\cdot\|' = a \|\cdot\|^\#$, and the induced distance is given as $dist'(\psi_x(\zeta_1), \psi_x(\zeta_2)) = a(x)|\zeta_1 - \zeta_2|$. Given a metric, we let $\Delta_x \subset W^u(x)$ denote the unit disk in $W^u(x)$ with center at x . We say that the metric is *admissible* if there are constants $0 < c' < c'' < \infty$ such that the diameter, measured with respect to the Euclidean metric on \mathbf{C}^2 satisfies

$$c' \leq diam_{\mathbf{C}^2}(\Delta_x) \leq c''$$

for all $x \in S$.

Admissibility of a metric is not a strictly local property since it involves the immersions ψ_x . If we work with the metric $\|\cdot\|^\#$, then the boundary Δ_x contains

a point of $\{G^+ = 1\} \cap J^-$. Since this is a compact set, we have an upper bound on the diameter of Δ_x . The lower bound on the diameter follows because this set is at positive distance from J (which contains x). Thus $\|\cdot\|^\#$ is admissible.

It need not be true that a metric equivalent to an admissible metric is itself admissible. For $0 < \tau \leq 1$, let us consider the scaled metric $\tau\|\cdot\|^\#$. With respect to this metric, Δ_x satisfies $\psi_x^{-1}\Delta_x = \{\zeta \in \mathbf{C}_x : |\zeta| < \frac{1}{\tau}\}$. It is evident that Ψ is a normal family if and only if the functions ψ_x are bounded on this set for each $\tau > 0$. For fixed τ , this gives an upper bound on $\sup_{x \in S} \text{diam}(\Delta_x)$. (The case $\tau = 1$ is already a lower bound.) Thus we see that f is quasi-expanding if and only if $\tau\|\cdot\|^\#$ is admissible for every $0 < \tau < 1$. In other words, if f is not quasi-expanding, then $\tau\|\cdot\|^\#$ is not admissible for some $0 < \tau < 1$.

LEMMA 4.11. *Any two admissible metrics are equivalent.*

Proof. Suppose that $\|\cdot\|$ and $\|\cdot\|'$ are admissible metrics. If they are not equivalent, we may choose a sequence x_k such that $\|\cdot\|_{x_k} = \epsilon_k \|\cdot\|'_{x_k}$, and $\lim_{k \rightarrow \infty} \epsilon_k = 0$. Let $D_k := \{\zeta \in \mathbf{C}_{x_k} : \|\zeta\|_{x_k} < 1\}$. Thus $D'_k := \{\zeta \in \mathbf{C}_{x_k} : \|\zeta\|'_{x_k} < 1\} = \epsilon_k D_k \subset D_k$. Let δ_k denote the diameter of D'_k , measured with respect to the Kobayashi metric of D_k .

Since $\|\cdot\|$ is admissible, there is a bounded set $B \subset \mathbf{C}^2$ such that $\Delta_k = \psi_{x_k}(D_k) \subset B$ for all k . Since the Kobayashi metric decreases under holomorphic mappings, the diameter of $\psi_{x_k}(D'_k)$, measured with respect to the Kobayashi metric of B is no larger than δ_k . Further, since B is bounded, the Kobayashi metric of B dominates the Euclidean metric. Thus for some constant $C < \infty$, the Euclidean diameter of $\Delta'_k = \psi_{x_k}(D'_k)$ is no larger than $\delta_k C$. But if $\epsilon_k \rightarrow 0$, it follows that the relative diameter δ_k also tends to zero. Thus the Euclidean diameters of Δ'_k are not bounded below, which contradicts the admissibility of $\|\cdot\|'$. This contradiction shows that the two metrics must be equivalent. \square

THEOREM 4.12. *If f is uniformly hyperbolic on J^* , then $\|\cdot\|^e$ is an admissible metric.*

Proof. Let \mathcal{W}^u denote the lamination of $W^u(J^*)$ by unstable manifolds. Each unstable manifold is uniformized by \mathbf{C} , and thus has a unique complex affine structure. It was shown in [BS7] that this affine structure varies continuously. For each $p \in J$, we may assign an affine metric on $W^u(p)$ by using the metric $\|\cdot\|_p^e$, induced by $\phi_p: \mathbf{C} \rightarrow W^u(p)$. By the continuity of the affine structure, the sets $\Delta_p = \psi_p\{\zeta \in \mathbf{C} : \|\zeta\|_p^e < 1\}$ vary continuously. In particular, their diameters will be bounded above and below in terms of the euclidean metric on \mathbf{C}^2 . \square

We conclude with another proof of Proposition 3.9.

COROLLARY 4.13. *If f is uniformly hyperbolic on J^* , then f and f^{-1} are quasi-expanding.*

Proof. Let c^e denote the cocycle corresponding to the euclidean metric. If f is uniformly hyperbolic, then c^e is eventually positive. Further, since both $\|\cdot\|^\#$

and (by Theorem 4.12) $\|\cdot\|^e$ are admissible, they are equivalent by Lemma 4.11. By Lemma 4.6, the cocycle $c^\#$ is eventually positive. By (4) of Theorem 1.2 and Proposition 1.3 it follows that f is quasi-expanding. \square

5. Local folding. In this section we show how conditions (\dagger) and (\ddagger) express themselves in terms of local folding. In Section 2 we showed how (\ddagger) corresponds to a bound on the local area of the varieties \mathcal{V} . Here we show (Propositions 5.1–3) how it corresponds to a bound on the local folding of \mathcal{V} .

For $\psi \in \Psi_x$, we define $\text{Ord}(\psi) = \min\{n \geq 1 : \psi^{(n)}(0) \neq 0\}$. Thus $\text{Ord}(\psi) < \infty$ if and only if ψ is nonconstant. If $j = \text{Ord}(\psi) < \infty$, then $\psi(\zeta) = x + a_j \zeta^j + \dots$, where we set $a_j = \psi^{(j)}(0)/j!$. By E_x we denote the complex linear span of a_j in $T_x \mathbb{C}^2$. E_x coincides with the tangent cone of the variety V_x at x (see [Ch §8]). By Lemma 2.6, E_x is independent of the choice of ψ . In the following discussion of folding, we will use the notation E_x to denote the complex affine line passing through x in the direction of the tangent cone of V_x at x . Let $\pi: \mathbb{C}^2 \rightarrow E_x$ denote a complex affine projection map. Let $\psi \in \Psi_x$ be nonconstant. For an open set $\mathcal{N} \subset E_x$, we let ω denote the connected component of $\psi^{-1}(\pi^{-1}\mathcal{N})$ containing 0. Since E_x is the tangent cone to $V(\psi)$ at x , we may choose \mathcal{N} sufficiently small that ω is relatively compact inside Δ . For $\hat{\psi} \in \Psi$, we let $V(\hat{\psi}, \mathcal{N})$ denote the connected component of $\psi(\Delta) \cap \pi^{-1}\mathcal{N}$ containing $\psi(0)$. If $\hat{\psi} \in \Psi$ is uniformly close to ψ in a neighborhood of $\bar{\omega}$, then $V(\hat{\psi}, \mathcal{N})$ is a subvariety of $\pi^{-1}\mathcal{N}$, and $\pi|_{V(\hat{\psi}, \mathcal{N})}: V(\hat{\psi}, \mathcal{N}) \rightarrow \mathcal{N}$ is proper. If $y = \hat{\psi}(0)$, then in analogy with Section 2, we may write $V(y, \mathcal{N})$ for $V(\hat{\psi}, \mathcal{N})$.

Let us define $\tau(x) := \sup_{\psi \in \Psi_x} \text{Ord}(\psi)$. If $\tau(x) = \infty$ then (\ddagger) does not hold.

PROPOSITION 5.1. *Suppose (\dagger) holds at x and $\tau(x) = \infty$. Then for each $k < \infty$ and for an arbitrarily small neighborhood \mathcal{N} of x inside E_x , there exists $y \in J^* \cap \pi^{-1}\mathcal{N}$ such that $V(y, \mathcal{N})$ is a nonsingular subvariety of $\pi^{-1}\mathcal{N}$, and $\pi|_{V(y, \mathcal{N})}: V(y, \mathcal{N}) \rightarrow \mathcal{N}$ is proper with mapping degree $\geq k$.*

Proof. Since $\tau(x) = \infty$, Ψ_x contains elements with arbitrarily high order. Thus for each k , there exists $\psi \in \Psi_x$ with $m := \text{Ord}(\psi) \geq k$. Let us choose $\{p_j\} \subset S$ such that $\lim_{j \rightarrow \infty} \phi_{p_j} = \psi$. As was observed above, we may choose j large and \mathcal{N} sufficiently small that $\pi|_{V(p_j, \mathcal{N})}: V(p_j, \mathcal{N}) \rightarrow \mathcal{N}$ is proper. Since $\phi_{p_j} \in \psi_S$, the varieties $V(p_j, \mathcal{N})$ are regular. The map $\zeta \mapsto \pi \circ \psi(\zeta)$ is m -to-1 near $\zeta = 0$. It follows that m is the mapping degree of $\pi|_{V(p_j)}: V(p_j) \rightarrow \mathcal{N}$. \square

PROPOSITION 5.2. *Suppose that x satisfies (\dagger) , and suppose that for each sufficiently small neighborhood \mathcal{N} of x inside E_x there exists y close to x such that $\pi|_{V(y, \mathcal{N})}: V(y, \mathcal{N}) \rightarrow \mathcal{N}$ is a proper map of degree k . Then $\tau(x) \geq k$. Further $\tau(x)$ is the smallest number with this property.*

Proof. We choose a sequence of neighborhoods \mathcal{N}_j decreasing to $\{x\}$ and let ψ_j be the corresponding functions. Passing to a subsequence, we may suppose that $\psi_j \rightarrow \psi \in \Psi_x$. For $\epsilon > 0$, we may choose \mathcal{N} small enough that $\psi^{-1}(\pi^{-1}\mathcal{N}) \subset$

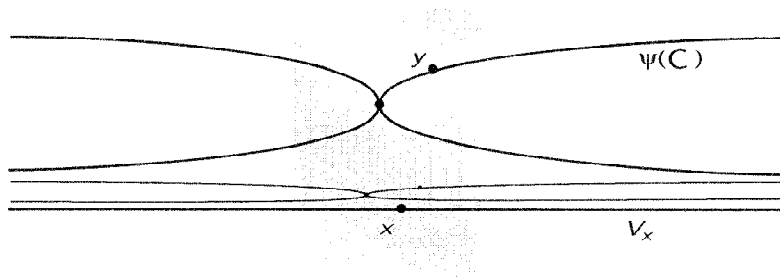

Figure 1.

$\{|\zeta| < \epsilon\}$. Thus for j large enough we have $\phi_j^{-1}(\pi^{-1}\mathcal{N}) \subset \{|\zeta| < \epsilon\}$. It follows that $\pi \circ \phi_j: \{|\zeta| < \epsilon\} \rightarrow \mathcal{N}$ is a k -to-one mapping. Thus $\psi: \{|\zeta| < \epsilon\} \rightarrow \mathcal{N}_\epsilon$ is k -to-one. Since this holds for all $\epsilon > 0$, it follows that $\text{Ord}(\psi) = k$.

To establish the final statement, we suppose first that $\tau(x) = \infty$. Then by Proposition 5.1, there are $\psi \in \Psi_x$ yielding branched covers of degree $\geq k$. If $\tau(x) < \infty$, we may choose $\psi \in \Psi_x$ with $\text{Ord}(\psi) = \tau(x)$. Again, by the argument of Proposition 5.1, there is a local branching of order $k = \tau(x)$. \square

For a positive integer k , we set $\mathcal{J}_k = \{x \in J^* : \tau(x) = k\}$. Thus $\mathcal{J}_1, \mathcal{J}_2, \dots$ is a partition of $\{x \in J^* : \tau(x) < \infty\}$. Since $J^* \ni x \mapsto \tau(x)$ is upper semicontinuous, the set $\bigcup_{k \geq m} \mathcal{J}_k$ is closed (and $\bigcup_{k < m} \mathcal{J}_k$ is open) in $\{x \in J^* : \tau(x) < \infty\}$ for each m .

Figure 1 illustrates the case where $\tau(x) = k$, and $\psi_x(\mathbf{C})$ is a nonsingular manifold. By Lemma 2.6, there is a neighborhood \mathcal{N} of x inside V_x ($\pi^{-1}\mathcal{N}$ is shaded in Figure 1) with the following properties. If $y \in \mathcal{J}$ is sufficiently close to x and $\psi \in \Psi_y$, then the variety $V_\psi(\mathcal{N})$ is a j -fold branched cover over \mathcal{N} . Also highlighted is a regular point where $\psi(\mathbf{C})$ has a vertical tangent. On compact sets outside the shaded neighborhood, $\psi(\mathbf{C})$ has the geometry of j distinct manifolds which approach $\psi_x(\mathbf{C})$ in the C^1 topology as $y \rightarrow x$.

We may interpret the mapping degree of $\pi|_{V_\psi(\mathcal{N})}$ as measuring the local folding of the variety $V_\psi(\mathcal{N})$ at x . The following result asserts that the maximal amount of local folding at x is given by $\tau(x)$, which also measures the maximal order of vanishing of the derivatives of the parametrizations.

PROPOSITION 5.3. *If $x \in \mathcal{J}_1$, there are neighborhoods $x \in \mathcal{U}_0 \subset \mathcal{U} \subset \mathbf{C}^2$ such that $\{V(y, \epsilon) \cap \mathcal{U} : y \in \bar{\mathcal{U}}_0 \cap J^*\}$ is a lamination. If $x \in J^* - \mathcal{J}_1$, then there is no such lamination at x .*

Proof. For $x \in \mathcal{J}_1$, every $\psi \in \Psi_x$ has nonvanishing differential at $\zeta = 0$. Since Ψ is a normal family, it follows that the images $V(x, \epsilon)$ are regular and form a lamination. Conversely, if $x_0 \in J^* - \mathcal{J}_1$, then for any open sets $\mathcal{U}_0 \subset \mathcal{U}$ containing x_0 , there will be varieties $V(x, \epsilon)$, $x \in \mathcal{U}_0 \cap J^*$ which project as in Figure 1. Thus there is no lamination at x_0 . \square

6. Expansion. For $x \in J^*$ and $k < \infty$, let us define $\Psi_x^k = \{\psi \in \Psi_x : \text{Ord}(\psi) = k\}$, and

$$\gamma_k(x) := \sup_{\psi \in \Psi_x^k} \left| \frac{\psi^{(k)}(0)}{k!} \right|,$$

which is finite by the normality of Ψ . We have $\mathcal{J}_k \subset \{\gamma_k > 0\}$, and the set of all points of J^* where (\dagger) holds coincides with $\bigcup_{k \geq 1} \{\gamma_k > 0\}$. By Lemma 2.6 and the normality of Ψ , it follows that $\{\gamma_k > 0\} \ni x \mapsto E_x$ is continuous. For $x \in J^*$ with $\gamma_k(x) > 0$, we define

$$\|v\|_x^{\#,k} := |v|/\gamma_k(x) \text{ for } v \in E_x.$$

Since Ψ is generated by the normal limits of elements of ψ_S , we have

$$\| \cdot \|_x^{\#,1} = \liminf_{p \in S, p \rightarrow x} \| \cdot \|_p^{\#},$$

where $\| \cdot \|_p^{\#}$ was defined in Section 1. Since $\gamma_k(x)$ is upper semicontinuous, we have an upper bound $m_k := \sup_{x \in J^*} \gamma_k(x) < \infty$, so we have a lower bound in terms of the euclidean metric:

$$\frac{|v|}{m_k} \leq \|v\|_x^{\#,k}, \text{ for } v \in E_x.$$

If $\phi \in \Psi_x^k$ (resp. $\phi_1 \in \Psi_{f^k x}^k$) realizes the supremum defining γ_k at x (resp. $f^k x$), then

$$(6.1) \quad |\lambda_{\bar{f}^{-1}\phi_1}|^k \leq \|Df_x^n\|^{\#,k} := \frac{\|Df_x^n v\|_{f^n x}^{\#,k}}{\|v\|_x^{\#,k}} \leq |\lambda_\phi|^k.$$

If (\dagger) holds, then $x \in \mathcal{J}_k$ for $k = \tau(x)$, and we define a metric $\| \cdot \|_x^{\#}$ on E_x by setting $\|v\|_x^{\#} := \|v\|_x^{\#,k}$ for $v \in E_x$. A priori this could disagree with the definition in (1.9) for $x = p \in S$, but we will show in Theorem 6.6 that these two definitions coincide. If S is a compact subset of \mathcal{J}_k , then $c := \inf_{x \in S} \gamma_k(x) > 0$. Thus for any compact $S \subset \mathcal{J}_k$

$$(6.2) \quad m_k^{-1}|v| \leq \|v\|_x^{\#} \leq c^{-1}|v|, \text{ for } x \in S, v \in E_x$$

gives an equivalence between $\| \cdot \|_x^{\#}$ and the euclidean metric.

PROPOSITION 6.1. *If $\gamma_k(x) > 0$, then $\|Df_x^n|E_x\|^e \leq C\gamma(x, n)$ for $n \leq 0$. If $n_j \rightarrow \infty$ is a sequence with $f^{n_j}x \rightarrow \hat{x} \in \mathcal{J}_k$, then there exists $c > 0$ such that $\|Df_x^{n_j}|E_x\|^e \geq c\lambda(x, n_j)$.*

Proof. By the definition of $\|\cdot\|^{#,k}$, we have

$$\|Df_x^n|E_x\|^e = \lambda(x, n) \frac{\gamma_k(f^n x)}{\gamma_k(x)}.$$

Thus $C = m/\gamma_k(x)$ is our desired bound. If $\hat{x} \in \mathcal{J}_k$, then $\eta := \liminf_{x \in \mathcal{J}_k, x \rightarrow \hat{x}} \gamma_k(x) > 0$. Thus if n_j is sufficiently large, we have $\gamma_k(f^{n_j} x) > \eta/2$, which gives the desired estimate with $c = \eta(2\gamma_k(x))^{-1}$. \square

Remark on expansion. We may interpret the proposition as follows. $Df_x^n|E_x$ has uniform contraction along the backward orbit of a point $x \in \mathcal{J}_k$. If there is a sequence of times $n_j \rightarrow \infty$ such that $\text{dist}(f^{n_j} x, \{\tau(x) < k\})$ is bounded below, then $Df_x^{n_j}|E_x^{n_j}$ has exponential growth during the times $n = n_j$.

THEOREM 6.2. *Let f be quasi-expanding, and let ν be an ergodic invariant measure supported on \mathcal{J} . Then the Lyapunov exponent of ν satisfies $\Lambda(\nu) \geq \log \kappa > 0$. If \mathcal{J}_k has full measure for ν , then $\Lambda(\nu) \geq k \log \kappa > 0$.*

Proof. The Lyapunov exponent of the measure ν is given by the formula

$$\Lambda(\nu) = \lim_{n \rightarrow \infty} \frac{1}{n} \int \log \|Df_x^n\| \nu(x).$$

Since the family E_x^u is invariant, it follows that

$$\frac{1}{n} \log \|Df_x^n\| \geq \frac{1}{n} \|Df_x^n|E_x^u\| = \frac{1}{n} \sum_{j=0}^{n-1} \log \|Df_{f^j x}|E_{f^j x}^u\|.$$

By the invariance of ν , we have $\int \log \|Df_{f^j x}|E_{f^j x}^u\| \nu(x) = \int \log \|Df_x|E_x^u\| \nu(x)$, so

$$\frac{1}{n} \int \log \|Df_x^n\| \nu(x) \geq \frac{1}{n} \int \log \|Df_x^n|E_x^u\| \nu(x) = \int \log \|Df_x|E_x^u\| \nu(x).$$

It will suffice to consider the case when all the mass of ν is on \mathcal{J}_k . For $x \in \mathcal{J}_k$ we have $\gamma_k(x) > 0$, so

$$\|Df_x|E_x^u\| = \frac{|Df_x \nu|_{f_x}}{|\nu|_x} = \|Df_x\|^{#} \frac{\gamma_k(fx)}{\gamma_k(x)}.$$

By [LS, Proposition 2.2], we have

$$\int \log \frac{\gamma_k(fx)}{\gamma_k(x)} \nu(x) = 0.$$

It follows from (6.1) that

$$\int \log \|Df_x|E_x^u\| \nu(x) = \int \log \|Df_x|E_x^u\|^\# \nu(x) \geq \log \kappa^k,$$

and the last inequality follows from (6.1). □

COROLLARY 6.3. *If f is quasi-expanding and quasi-contracting, then every periodic point in J^* is a saddle point. Further, there is a $\kappa > 1$ such that if λ^+ and λ^- denote the larger and smaller eigenvalues of Df^n at a saddle point of period n , then $|\lambda^-| \leq \kappa^{-n} < \kappa^n \leq |\lambda^+|$.*

Let us use the notation $\mathcal{J}'_k = \{x \in \mathcal{J}_k : \alpha(x) \cap \mathcal{J}_k \neq \emptyset\}$, where $\alpha(x)$ is the α -limit set, i.e., the accumulation points of sequences $f^{n_j}x$ with $n_j \rightarrow -\infty$. By the Poincaré Recurrence Theorem, \mathcal{J}'_k has full measure for any invariant measure on \mathcal{J}_k . If \mathcal{J}_k is compact (which occurs, for instance, if $k = \sup_{x \in J^*} \tau(x) < \infty$), then $\mathcal{J}'_k = \mathcal{J}_k$.

LEMMA 6.4. *Let $x \in \mathcal{J}'_k$ be a point of backward contraction. If $\psi \in \Psi_x$, then the number of critical points of ψ , counted with multiplicity, is no greater than $k - 1$; and for $\zeta \in \mathbf{C}$, the number of preimages $\psi^{-1}(\psi(\zeta))$, of a point $\psi(\zeta)$ is no greater than k .*

Proof. Let ζ_1, \dots, ζ_j be critical points of ψ . Then $\tilde{f}^{-n}(\psi)$ has critical points at $\lambda(x, -n)\zeta_i$ for $1 \leq i \leq j$. Let $\tilde{\psi} \in \Psi_y$ denote any normal limit of a subsequence of $\tilde{f}^{-n}(\psi)$. By the backward contraction, all the critical points converge to the origin in the limit, so it follows that $\text{Ord}(\tilde{\psi})$ is one greater than the sum of the multiplicities of the critical points ζ_1, \dots, ζ_j . Since $\alpha(x) \cap \mathcal{J}_k \neq \emptyset$, we may take the subsequence such that $y \in \mathcal{J}_k$. Thus $\text{Ord}(\tilde{\psi}) \leq k$, and thus the total orders of the critical points must be less than k . A similar argument shows that $\#\psi^{-1}(\psi(\zeta)) \leq k$. □

In Figure 2 we suppose that p is a saddle point and that the unstable manifolds $W^u(p_j)$ and $W^u(q_j)$ are smooth. Let $\phi_p: \mathbf{C} \rightarrow W^u(p) \subset \mathbf{C}^2$, $\phi_{p_j}: \mathbf{C} \rightarrow W^u(p_j) \subset \mathbf{C}^2$, and $\phi_{q_j}: \mathbf{C} \rightarrow W^u(q_j) \subset \mathbf{C}^2$ be holomorphic embeddings. Let $\beta_j, \gamma_j \in \mathbf{C}$ be such that $\phi_{p_j}(\beta_j) = x_j$, $\phi_{q_j}(\gamma_j) = y_j$, and $\phi_p(\beta) = x$. It follows that $\phi_{q_j} \rightarrow \phi_p \in \Psi_p$, $\gamma_j \rightarrow \beta$, and $\phi_{q_j}(\zeta + \gamma_j) \rightarrow \phi_p(\zeta + \beta) \in \Psi_x$. If $W^u(p_j)$ and $W^u(p)$ have a simple (quadratic) tangency at p_j , then $\phi_{p_j}(\zeta) \rightarrow \phi_p(\alpha\zeta^2) \in \Psi_p$ for some $|\alpha| = 1$, and $\phi_{x_j}(\zeta) \rightarrow \phi_p(\alpha(a\zeta + b)^2) \in \Psi_x$, where $a, b \in \mathbf{C}$ are chosen so that (1.3) holds. Figure 2 is consistent with the properties $x \in \mathcal{J}_1$ and $p \in \mathcal{J}_2$.

We say that $\psi \in \Psi$ is a *homogeneous parametrization* if it has the form $\psi(\zeta) = \phi(c\zeta^k)$, where $c \in \mathbf{C}$, and $\phi: \mathbf{C} \rightarrow \mathbf{C}^2$ is an immersion. If $\psi_1, \psi_2 \in \Psi_x^k$ are two homogeneous parametrizations, then by (1.3) and Lemma 2.6, they differ only by a rotation of the variable ζ .

LEMMA 6.5. *Let $x \in \mathcal{J}'_k$ be a point of backward contraction. If $\phi: \mathbf{C} \rightarrow \mathbf{C}^2$ is an immersion which induces V_x , then there is a polynomial $p(\zeta)$ of degree no*

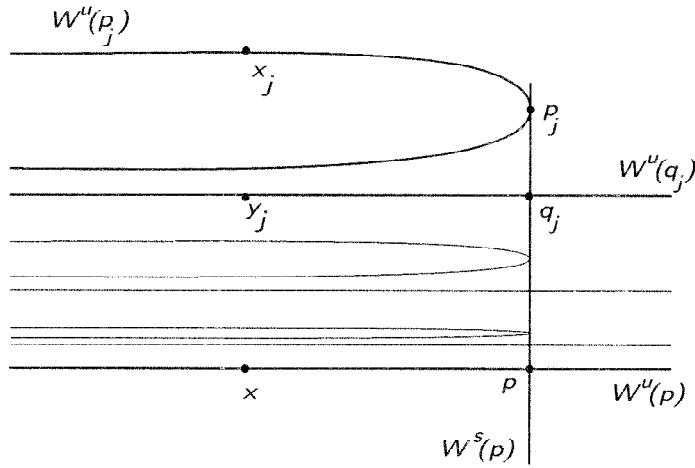

Figure 2.

greater than k such that $p(0) = 0$ and $\psi(\zeta) = \phi(p(\zeta))$. In particular, every $\psi \in \Psi_x^k$ is a homogeneous parametrization.

Proof. If ϕ is an immersion, then we claim that $p := \phi^{-1} \circ \psi: \mathbf{C} \rightarrow \mathbf{C}$ is a well-defined holomorphic mapping. It is evident that p is analytic on the domain $\mathcal{D} := \{\zeta \in \mathbf{C} : \psi(\zeta) \in \phi(\mathbf{C})\}$. Note that we must have $p(\zeta) \rightarrow \infty$ as $\zeta \rightarrow \partial\mathcal{D}$. Otherwise, if $\zeta_j \rightarrow \zeta_0 \in \partial\mathcal{D}$ and $p(\zeta_j) \rightarrow c_0 \in \mathbf{C}$ we have $p(\zeta_0) = \phi^{-1}(\psi(\zeta_0)) = c_0$, so $\psi(\zeta_0) = \phi(c_0)$, which means that $\zeta_0 \in \mathcal{D}$. It follows that $1/p$ may be extended to a continuous function on \mathbf{C} by setting it equal to 0 on $\mathbf{C} - \mathcal{D}$. By Radó's Theorem, then, it follows that $1/p$ is holomorphic on \mathbf{C} , which means that $\mathbf{C} - \mathcal{D}$ is a discrete set. By the argument above, p has a pole at each $\zeta_0 \in \mathbf{C} - \mathcal{D}$. But if $\lim_{\zeta \rightarrow \zeta_0} p(\zeta) = \infty$, then $\lim_{\zeta \rightarrow \infty} \phi(\zeta) = \psi(\zeta_0)$, forcing ϕ to be constant. This completes the proof of the claim. By Lemma 6.4, ψ is at most k -to-one, it follows that p is a polynomial of degree no greater than k .

If, in addition, $\text{Ord}(\psi) = k$, then the multiplicity of the critical point of the origin is already $k - 1$, so we must have $p(\zeta) = \alpha\zeta^k$. □

THEOREM 6.6. *Let ψ_S be as in Example 2 in Section 1. Then the definition of $\| \cdot \|_p^\#$ as given in (1.9) coincides with the definition given after (6.1).*

Proof. Let $\phi: \mathbf{C} \rightarrow W^u(p)$ denote the normalized uniformization. If $\phi(\zeta) = p + a\zeta + \dots$, then $\|v\|_p^\# = |v/a|$, according to the definition (1.9).

For the second definition, we let k be such that $p \in \mathcal{J}_k^!$. If $\psi \in \Psi_p$, it follows from Lemma 6.5 that $\psi(\zeta) = \phi(c\zeta^k)$ for some scalar c with $|c| = 1$. Since any two homogeneous parametrizations agree up to a rotation of parameter, a must be maximal, so $\|v\|_p^\# = |v/a|$ according to the definition after (6.1). □

THEOREM 6.7. *If f is quasi-expanding, then \mathcal{J}_1 is an open, dense subset of \mathcal{J} .*

Proof. Suppose that k is the minimum value of τ on \mathcal{J} . It follows that $\mathcal{J}_k = \{\tau < k + 1\}$ is an open set. Since \mathcal{J}_k is f -invariant, and since \mathcal{J}_k is a nontrivial open subset of the support of μ , it follows that \mathcal{J}_k has full μ measure and is thus dense in $\mathcal{J} = \text{supp}(\mu)$. It will suffice to show that $k = 1$.

First we claim that for $x \in \mathcal{J}_k$, each $g \in \Psi_x$ with $\text{Ord}(g) = k$ has the form $g = \psi(\alpha\zeta^k)$. Let $x \in \mathcal{J}_k$ be a periodic point, and let $\phi_x: \mathbb{C} \rightarrow W^u(x)$ denote the uniformization of the unstable manifold, normalized to satisfy (1.3). Let $g_x \in \Psi_x$ be a map such that $\text{Ord}(g_x) = k$. It follows from Lemma 6.5 that $g_x(\zeta) = \phi_x(\alpha_x\zeta^k)$ with $|\alpha_x| = 1$. For general $x_0 \in \mathcal{J}_k$, we may let x_j be a sequence of periodic points converging to x_0 . Passing to a subsequence if necessary, we have that $g_{x_j} = \phi_{x_j}(\alpha_{x_j}\zeta^k)$ converges to $g_{x_0} \in \Psi_{x_0}$, and $\alpha_{x_j} \rightarrow \alpha$. It follows that ϕ_{x_j} converges to a function $\phi: \mathbb{C} \rightarrow \mathbb{C}$ with $g_{x_0}(\zeta) = \phi(\alpha\zeta^k)$.

For $x \in S$, let $\psi_x \in \psi_S$. We know that $\omega(x) \subset \mathcal{J}$, so $\omega(x) \cap \mathcal{J}_m \neq \emptyset$ for some m . By Lemma 6.5 there is a polynomial $p_x(\zeta)$ of degree no greater than m , with $p(0) = 0$, such that $\phi(\zeta) = \psi_x(p_x(\zeta))$. Thus $g_x = \psi_x(p_x(\alpha\zeta^k))$.

Now let $h \in \Psi_x$ be an element with $\text{Ord}(h) = k$. There exist immersions $\psi_{x_i} \in \psi_S$ which converge to h . For each i , let $g_{x_i} \in \Psi_{x_i}$ be an element such that $\text{Ord}(g_{x_i}) = k$. Then as above we have a mapping ϕ_i such that $g_{x_i}(\zeta) = \phi_i(\alpha_i\zeta^k)$. Since ϕ_i and ψ_{x_i} both have the normalization (1.3), we have $g_{x_i} = \psi_{x_i}(p_{x_i}(\alpha_i\zeta^k))$. Since Ψ is a normal family, we may extract a subsequence so that $g_{x_i} \rightarrow G \in \Psi_x$.

Next we claim that the polynomials $\{p_{x_i}\}$ form a normal family. Since the degree of p_{x_i} is bounded by m , it suffices to show that $C_i := \max_{|\zeta| \leq 1} |p_{x_i}|$ is bounded. For each i , let r_i denote the radius of the largest disk centered at the origin and contained in the image $p_{x_i}(|\zeta| < 1)$. Since ϕ_i and ψ_{x_i} are normalized according to (1.3), we must have $r_i \leq 1$. We suppose that $C_i \rightarrow \infty$ and derive a contradiction. We have $C_i^{-1} \max_{|\zeta| \leq 1} |p_{x_i}(\zeta)| = 1$, so we may extract a subsequence such that $C_i^{-1} p_{x_i} \rightarrow q$, a polynomial of degree no greater than m . Again we have $q(0) = 0$ and $\max_{|\zeta| \leq 1} |q(\zeta)| = 1$, so that q is nonconstant. Thus $q(|\zeta| \leq 1)$ contains the neighborhood of the origin. On the other hand, the interior radius r_i for p_{x_i} is replaced by $C_i^{-1} r_i \rightarrow 0$, which is a contradiction. Thus $\{p_{x_i}\}$ is normal family, and we may pass to a subsequence such that $p_{x_i} \rightarrow p$.

Passing to further subsequences, we also have $g_{x_i} = \psi_{x_i}(p_{x_i}(\zeta^k)) \rightarrow h(p(\zeta^k))$. Thus $G = h(p(\zeta^k))$ has order k^2 at $\zeta = 0$. Since k is the maximal order on \mathcal{J}_k , we have $k^2 \leq k$, so $k = 1$. □

7. Regularity. In the sequel we consider points x where (\dagger) holds for both f and f^{-1} . We use the superscripts u and s to distinguish between the “unstable” objects $V^u, \Psi^u, E^u, \gamma^u, \tau^u$, and the “stable” objects $V^s, \Psi^s, E^s, \gamma^s, \tau^s$ (i.e., the corresponding objects for f^{-1}). With this notation, the backward contraction condition is now written $\hat{\lambda}^u(x, n) \rightarrow 0$ as $n \rightarrow -\infty$, and forward expansion is written $\hat{\lambda}^u(x, n) \rightarrow \infty$ as $n \rightarrow +\infty$. By *forward contraction* we will mean $\hat{\lambda}^s(x, n) \rightarrow 0$ as $n \rightarrow +\infty$, and by *backward expansion* we will mean $\hat{\lambda}^s(x, n) \rightarrow \infty$

as $n \rightarrow -\infty$. \mathcal{J}_k will now be written $\mathcal{J}_{*,k}$, and the set \mathcal{J}_j corresponding to f^{-1} will be written $\mathcal{J}_{j,*}$. We set $\mathcal{J}_{j,k} = \mathcal{J}_{j,*} \cap \mathcal{J}_{*,k}$.

PROPOSITION 7.1. *If V_x^s and V_x^u exist at x , and if x is a point of forward expansion, then $V_x^s \neq V_x^u$, i.e., the germs cannot coincide.*

Proof. As was noted after equation (3.1), $V_x^u \subset J^-$, and furthermore, $V_x^s \subset J^+$. Thus if $V_x^s = V_x^u$, then $V_x^u \subset \{G^+ = 0\}$. If $\psi \in \Psi_x^u$ is nonconstant, then $m_\psi(r) = \max_{|\zeta| \leq r} G^+(\psi(\zeta))$ vanishes for some $r > 0$. But by Proposition 2.2 we cannot have $\lambda(x, n) \rightarrow \infty$ as $n \rightarrow \infty$. \square

We define $\mathcal{J}'_{j,k} = \{x \in \mathcal{J}_{j,k} : \alpha(x) \cap \mathcal{J}_{j,k} \neq \emptyset\}$.

PROPOSITION 7.2. *If $x \in \mathcal{J}'_{j,k}$ is a point of backward contraction, then $E_x^u \neq E_x^s$.*

Proof. Let us suppose $E_x^s = E_x^u$, and let us write $g = f^{-1}$. Then by (4.2)

$$\|Df_x^{-n}|_{E_x^s}\|^{\#,s} = \|Dg_x^n|_{E_x^s}\|^{\#,s} \geq 1$$

for $n \geq 0$, where $\|\cdot\|^{\#,s}$ denotes the metric $|\cdot|/\gamma_j^s$ for f (or the expanding metric for g), and

$$\|Df_x^{-n}|_{E_x^u}\|^{\#,u} = \lambda(x, -n).$$

Let us select a subsequence $-n_j \rightarrow -\infty$ such that $f^{-n_j}x \rightarrow \hat{x} \in \mathcal{J}_{j,k}$. By (6.2) we know that on the compact set $\{\hat{x}\} \cup \{f^{-n_j}x : j = 1, 2, 3, \dots\}$ the metrics $\|\cdot\|^{\#,s}$ and $\|\cdot\|^{\#,u}$ are comparable to the euclidean metric, which contradicts the backward contraction. \square

Let V denote a 1-dimensional subvariety of \mathbf{C}^2 in a neighborhood of x . Choose a holomorphic coordinate system (z, w) with the property that $x = (0, 0)$, and $V \cap \{|z|, |w| \leq 1\} \subset \{|w| \leq |z|^\tau\}$. If V is regular at x , then τ may be taken arbitrarily large, and we write $\tau_x(V) = \infty$. Otherwise, if V is singular at x , there is a maximal possible value of τ , which we write as $\tau_x(V)$. In fact, if h is a local defining function for V at x , we may compute $\tau_x(V)$ in terms of the Taylor expansion of h at x . If V_1 and V_2 are regular curves passing through x , then we may choose local coordinates (z, w) such that $V_1 = \{w = 0\}$ and $V_2 = \{w = a_m z^m + O(|z|^{m+1})\}$. It follows that $\tau_x(V_1 \cup V_2) = m$ agrees with the order of tangency of V_1 and V_2 at x in this case. If V_1 or V_2 is not regular, then the geometric interpretation of τ_x is less clear to us.

For $x \in \mathcal{J}_{j,k}$, we define

$$\tau^i(x) = \tau_x(V_x^s \cup V_x^u).$$

We define $\mathcal{J}^i_{j,k} = \{x \in \mathcal{J}_{j,k} : \tau^i(x) = i\}$.

If f and f^{-1} are quasi-expanding, then by Theorem 6.7 $\mathcal{J}_{1,1}$ is a dense, open subset of J^* . Since $\mathcal{J}_{1,*} \ni x \mapsto E_x^s$ and $\mathcal{J}_{*,k} \ni x \mapsto E_x^u$ are continuous, and since $\mathcal{J}_{1,1}^1$ contains the saddle points (where $E_x^u \neq E_x^s$) it follows that $\mathcal{J}_{1,1}^1$ is a dense, open subset of J^* .

It is useful to have the following quantitative version of Proposition 7.2.

THEOREM 7.3. *Let $x \in \mathcal{J}'_{j,k}$ be a point of backward contraction. Let $\tau = [\tau^l(x)]$ denote the greatest integer in $\tau^l(x)$. Then $\tau^s(\hat{x}) \geq j\tau$ for all $\hat{x} \in \alpha(x)$.*

Proof. Let (A, B) denote a local holomorphic coordinate system such that x corresponds to the point $(0, 0)$, and

$$(7.1) \quad \{|A|, |B| \leq 1\} \cap (V_x^s \cup V_x^u) \subset \{|B| \leq |A|^\tau\}.$$

We may write

$$f^n(A, B) = \alpha_0(n) + \alpha_1(n)A + \cdots + \alpha_{\tau-1}(n)A^{\tau-1} + O(|A|^\tau + |B|)$$

with $\alpha_j(n) \in \mathbb{C}^2$. Our first object is to show that $\alpha_r(n) \rightarrow 0$ for $1 \leq r \leq \tau - 1$ as $n \rightarrow -\infty$. Let us choose $\psi^u \in \Psi_x^u$ such that

$$\psi^u(\zeta) = (c\zeta^k, 0) + O(\zeta^{k+1})$$

for some $c \neq 0$. If we set $\lambda = \lambda^u(\psi^u, n)$ and $\alpha_j = \alpha_j(n)$, then we have

$$\tilde{f}^n \psi^u(\zeta) = f^n \circ \psi^u(\lambda^{-1}\zeta) = \alpha_0 + \sum_{r=1}^{\tau-1} \alpha_r \left(c\lambda^{-k}\zeta^k + O(\lambda^{-k-1}\zeta^{k+1}) \right)^r + \cdots$$

The power series coefficients of $\tilde{f}^n \psi^u(\zeta)$ are bounded as $n \rightarrow -\infty$. The coefficient of ζ^k is $\alpha_1 c \lambda^{-k}$. By the backward contraction we have $\lambda \rightarrow 0$ as $n \rightarrow -\infty$; and since $c \neq 0$, it follows that $\alpha_1 \rightarrow 0$ as $n \rightarrow -\infty$.

To proceed by induction, let us suppose that $\alpha_t(n) \rightarrow 0$ for $1 \leq t \leq r - 1$ as $n \rightarrow -\infty$. The coefficient of ζ^{rk} is

$$(\alpha_1 E_1 + \cdots + \alpha_{r-1} E_{r-1} + \alpha_r c^r) \lambda^{-kr}.$$

Here the E_t denote expressions in the coefficients of ψ^u which are independent of n . Since $\alpha_t \rightarrow 0$ as $n \rightarrow -\infty$ for $1 \leq t \leq r - 1$, it follows that $\alpha_r c^r \lambda^{-kr}$ is bounded, so $\alpha_r \rightarrow 0$ as $n \rightarrow -\infty$.

Now we write $\psi^s(\zeta) = (\psi_1^s(\zeta), \psi_2^s(\zeta)) = (c\zeta^j, 0) + O(\zeta^{j+1})$ for some nonzero constant c . If we set $\lambda = \lambda^s(\psi^s, n)$ and $\alpha_r = \alpha_r(n)$, we have

$$\begin{aligned} \tilde{f}^n \psi^s &= f^n \circ \psi^s(\lambda^{-1}\zeta) \\ &= \alpha_0 + \sum_{r=1}^{\tau-1} \alpha_r \left(c(\lambda^{-1}\zeta)^j + O((\lambda^{-1}\zeta)^{j+1}) \right)^r + O(|\psi_1^s|^\tau + |\psi_2^s|). \end{aligned}$$

For $\hat{x} \in \alpha(x)$ there exists a sequence $n_i \rightarrow -\infty$ such that $f^{n_i}(x) \rightarrow \hat{x}$. We may pass to a subsequence so that $\tilde{f}^{n_i}\psi^s$ converges to an element $\hat{\psi} \in \Psi_{\hat{x}}^s$. Now we have $\alpha_r \rightarrow 0$ for $n \rightarrow -\infty$ for $1 \leq r \leq \tau - 1$, and (always) $|\lambda_n^s|^{-1} \leq 1$, so it follows that all the coefficients of the terms

$$\alpha_r \left(c\lambda^{-j}\zeta^j + O(\lambda^{-j-1}\zeta^{j+1}) \right)^r$$

tend to zero as $n = n_i \rightarrow -\infty$. We conclude that the only nonvanishing terms in $\hat{\psi}$ arise from the expression $O(|\psi_1^s|^\tau + |\psi_2^s|)$. However, $(\psi_1^s)^\tau = O(\zeta^{j\tau})$ by definition, and $|\psi_2^s| \leq C|\psi_1^s|^\tau = O(\zeta^{j\tau})$ by the tangency condition. It follows that $\text{Ord}(\hat{\psi}) \geq j\tau$. \square

If V is a germ of a variety at $x \in \mathbf{C}^2$ which is locally irreducible at x , then there is a holomorphic coordinate system (w, z) in a neighborhood of x such that $x = (0, 0)$, and V is represented near $(0, 0)$ in terms of a Puiseux series

$$(7.2) \quad w = a_j z^{j/m} + a_{j+1} z^{(j+1)/m} + \dots = \sum_{n=j}^{\infty} a_n z^{n/m}.$$

(See [Ch, §10] for details.) Choosing the z -axis to be the tangent cone, we have $j/m > 1$. If $j/m \in \mathbf{Z}$, we may replace w by $w' = w - a_j z^{j/m}$. If V is regular at x , i.e., if V is a complex manifold in a neighborhood of x , then we may continue this procedure and obtain a coordinate system (w', z') such that $V = \{w' = 0\}$ in a neighborhood of the origin. If V is not regular, we may continue this procedure to the point where we have $a_j \neq 0$, $j/m \notin \mathbf{Z}$, and $j/m > 1$.

THEOREM 7.4. *Let $x \in \mathcal{J}_{jk}^l$ be a point of backward contraction. Then V_x^u is a (nonsingular) manifold in a neighborhood of x .*

Proof. Suppose that V_x^u is not regular at x . Choose a holomorphic coordinate system (z, w) at $x = (0, 0)$ such that V_x has a Puiseux representation (7.2) with $a_j \neq 0$, $j/m \notin \mathbf{Z}$, and $j/m > 1$. Now choose $\psi \in \Psi_x^{k,u}$. We may assume that ψ has the form

$$\psi(\zeta) = (\psi_1(\zeta), \psi_2(\zeta)) = (\zeta^k + c_{k+1}\zeta^{k+1} + \dots, \zeta^\ell + \dots)$$

with $\ell/k = j/m$. Let us define coefficients $\alpha_{r,t}(n) \in \mathbf{C}^2$ such that

$$f^n(A, B) = \sum_{r,t=1}^{\infty} \alpha_{r,t}(n) A^r B^t.$$

If we set $\lambda = \lambda^u(x, n)$ and $\alpha_{r,t} = \alpha_{r,t}(n)$, then

$$\tilde{f}^n \psi(\zeta) = f^n(\psi(\lambda^{-1}\zeta)) = \alpha_{0,0} + \alpha_{1,0}(\lambda^{-k}\zeta^k + \dots) + \dots + \alpha_{1,0}(\lambda^{-\ell}\zeta^\ell + \dots).$$

Since $\{\tilde{f}^n\psi : n \leq 0\}$ is a normal family, all of its power series coefficients are bounded. The coefficient of ζ^k is $\alpha_{1,0}\lambda^{-k}$. Now by backward contraction it follows that $\alpha_{1,0} \rightarrow 0$ as $n \rightarrow -\infty$.

Define q by the property $kq < \ell < k(q + 1)$. We next show that $\alpha_{t,0} \rightarrow 0$ as $n \rightarrow -\infty$, for $1 \leq t \leq q$. We proceed by induction, assuming that $\alpha_{t,0} \rightarrow 0$ for $1 \leq t \leq r - 1$. The coefficient of ζ^{rk} in $\tilde{f}^n\psi$ is

$$\lambda^{-rk}[\alpha_{1,0}E_{r,1} + \alpha_{2,0}E_{r,2} + \cdots + \alpha_{r-1,0}E_{r,r-1} + \alpha_{r,0}],$$

where $E_{r,t}$ denotes a polynomial in the coefficients of ψ . Now $E_{r,t}$ is independent of n , and $\alpha_{1,0}, \dots, \alpha_{r-1,0} \rightarrow 0$ as $n \rightarrow -\infty$, so we conclude that $\alpha_{r,0} \rightarrow 0$. Similarly, the coefficient of ζ^ℓ is

$$\lambda^{-\ell}[\alpha_{0,1} + \alpha_{1,0}E_{\ell,1} + \cdots + \alpha_{q,0}E_{\ell,q}],$$

and we conclude that $\alpha_{0,1} \rightarrow 0$ as $n \rightarrow -\infty$.

We conclude, therefore, that $Df^n \rightarrow 0$ as $n \rightarrow -\infty$. But let $\hat{x} \in \alpha(x) \cap \mathcal{J}_{j,k}$ be given, and extract a subsequence $-n_j \rightarrow -\infty$ such that $f^{-n_j} \rightarrow \hat{x}$. We let $g = f^{-1}$, and apply Proposition 6.1 to g . We conclude that $\|Dg^{n_j}|E_{g^{n_j,x}}\|^e$ is bounded below by a constant (since we always have $\lambda(x, n_j) \geq 1$). Thus Df^n cannot tend to zero, and thus V_x cannot have a singular Puiseux representation. \square

COROLLARY 7.5. *Let $x \in \mathcal{J}'_k$ be a point of backward contraction. Then, modulo rotation, there is exactly one element of $\Psi_x^{k,u}$, and this is a homogeneous parametrization. Further, for $\psi \in \Psi_x^{k,u}$,*

$$\hat{\lambda}_x^k = |\lambda_\psi|^k = \|Df_x\|^\#.$$

Proof. Let $\psi \in \Psi_x^{k,u}$ be given. By Theorem 7.4, V_x is a regular variety at x . Thus we may define a branch of $\phi(\zeta) := \psi(\zeta^{1/k})$, which is holomorphic at $\zeta = 0$. Thus $\phi'(0) \neq 0$. By Lemma 6.4, $\psi'(\zeta) \neq 0$ for $\zeta \neq 0$, so it follows that ϕ is an immersion. The uniqueness of ψ now follows from Lemma 6.5. The equation now follows from (6.1). \square

We have noted earlier that $\mathcal{J}_{*,k} \ni x \mapsto E_x^u$ is continuous. It follows that the points of $\mathcal{J}'_{*,k}$ are points of continuity of the metric $\mathcal{J}_{*,k} \ni x \mapsto \|\cdot\|_x^\#$ on E^u .

COROLLARY 7.6. *Let $x \in \mathcal{J}'_{j,k}$ be a point of backward contraction. Then*

$$\|\cdot\|_x^\# = \lim_{\mathcal{J}_{j,k} \ni y \rightarrow x} \|\cdot\|_y^\#.$$

Proof. For $y \in \mathcal{J}_{j,k}$, we choose $\psi_y \in \Psi_y^{k,u}$ such that $\|v\|_y^\# = |v/(\psi_y^{(k)}(0)/k!)|$. If $\{y_i\} \subset \mathcal{J}_{j,k}$ is any sequence converging to x , then ψ_{y_i} converges to an element of

$\Psi_x^{k,u}$. Since $\Psi_x^{k,u}$ consists of homogeneous parametrizations, which are essentially unique, $\lim_{i \rightarrow \infty} \psi_{y_i}^i$ exists (modulo rotation), and thus the norms must converge. \square

8. Hyperbolicity. In this section we explore conditions that imply that f is (uniformly) hyperbolic, as well as ways in which hyperbolicity can fail. For instance in Theorem 8.3 we show that purely geometric conditions on J^\pm are sufficient to guarantee hyperbolicity. We show in Corollary 8.4 if f is quasi-expanding, quasi-contracting and expansive, then f is uniformly hyperbolic. Finally, we show (Corollary 8.6) that for a special class of nonhyperbolic maps there are points of tangency, i.e., points where $E_x^s = E_x^u$.

In this section let us make the standing assumption that, unless otherwise stated, f is quasi-expanding and quasi-contracting.

PROPOSITION 8.1. *If $S \subset \mathcal{J}_{j,k}^i$ is a compact, invariant set, then $i = 1$, and S is a (uniformly) hyperbolic set for f .*

Proof. Recall that $\mathcal{J}_{jk} \ni x \mapsto E_x^{s/u}$ is continuous. By the compactness of S we have $\alpha(x) \subset S \subset \mathcal{J}_{jk}^i$ for all $x \in S$. Thus by Proposition 7.2 $E_x^s \neq E_x^u$, and so $i = 1$. This gives us a continuous splitting of $T_x \mathbb{C}^2$ for $x \in S$, and so by compactness the angle between E_x^s and E_x^u is bounded below. The uniform expansion/contraction of Df on $E^{s/u}$ follows from Proposition 6.1. \square

Consider the (finite) collection of index pairs (j, k) for which $\mathcal{J}_{j,k} \neq \emptyset$. We define a partial ordering on this collection of index pairs as follows. We say $(j, k) \geq (a, b)$ if $j \geq a$, $k \geq b$, and $\mathcal{J}_{j,k} \neq \emptyset$. By the semicontinuity of τ^s and τ^u , $\mathcal{J}_{j,k}$ is compact for a maximal pair (j, k) . By Proposition 8.1, then, $\mathcal{J}_{j,k}$ is a hyperbolic set for all maximal pairs (j, k) .

Let us consider ways in which hyperbolicity can fail to hold for f . If f and f^{-1} are both quasi-expanding, then hyperbolicity (or the failure of hyperbolicity) along an orbit is determined by the position of the orbit with respect to the strata $\mathcal{J}_{j,k}^i$. For a point $x \in \mathcal{J}_{j,k}^1$, there is always uniform contraction in the direction E_x^s along the forward orbit (apply Proposition 6.1 to f^{-1}). If $Df^n|E_x^u$ is not uniformly expanding for $n \geq 0$, then there is a subsequence $n_l \rightarrow \infty$ for which $f^{n_l}x \rightarrow \{\tau^u > k\}$. An alternative is that hyperbolicity may fail along a forward orbit because the angle between $E_{f^{n_l}x}^s$ and $E_{f^{n_l}x}^u$ is not bounded below. In this case we have a subsequence $\{n_l\}$ with $f^{n_l}x \rightarrow \{\tau^l > 1\}$. By similar reasoning, we see that the failure of hyperbolicity along a backward orbit is caused either by $f^{-n_m}x \rightarrow \{\tau^s > j\}$ or by $f^{-n_m}x \rightarrow \{\tau^l > 1\}$, or both.

Theorem 8.3 gives a criterion for hyperbolicity for general polynomial diffeomorphisms (that is to say we make no a priori assumption that f is quasi-expanding and quasi-contracting) which refers only to the geometry of J^+ and J^- and makes no direct reference to f . For this we will need a preliminary result.

LEMMA 8.2. *Let $\mathcal{N} \subset \mathbb{C}^2$ be an open set, and let \mathcal{L} be a Riemann surface lamination of $\mathcal{N} \cap \partial K^+$. If T is a smooth 2-dimensional transversal to \mathcal{L} at $p \in \mathcal{N} \cap \partial K^+$, then p is in the closure of $T - K^+$.*

Proof. Since \mathcal{L} is a lamination, there is a neighborhood \mathcal{U} of p such that the restriction $\mathcal{L}|_{\mathcal{U}}$ is homeomorphic to the trivial lamination of $S \times \Delta$, where Δ is the unit disk, and $S \subset \Delta$ is closed. By Slodkowski [S], \mathcal{L} may be extended to a lamination \mathcal{L}^* of \mathcal{U} . Shrinking \mathcal{U} , we may suppose that the restriction $\mathcal{L}^*|_{\mathcal{U}}$ is homeomorphic to the (trivial) lamination of $\Delta \times \Delta$, whose leaves are $\{q\} \times \Delta$.

Since \mathcal{L}^* extends a lamination of $\mathcal{U} \cap \partial K^+$, there are sets $S_0, S_1 \subset \Delta$ such that the leaves corresponding to $\{q\} \times \Delta$ fill out $\mathcal{U} \cap K^+$ as q ranges over S_0 and they fill out $\mathcal{U} - K^+$ as q ranges over S_1 . Further, the leaves corresponding to ∂S_0 fill out $\mathcal{U} \cap \partial K^+$.

For $x \in \Delta$, we define $\chi(x)$ as the intersection point of T and the leaf corresponding to $\{x\} \times \Delta$. Since T is transversal, χ is defined and continuous (possibly after shrinking \mathcal{U}). Let $\hat{p} \in \partial S_0$ be such that $\chi(\hat{p}) = p$. Now there are points $q \in S_1$ arbitrarily close to \hat{p} , and so the points $\chi(q) \in T - K^+$ are arbitrarily close to p . \square

In the following theorem we make no a priori assumption about quasi-expansion or quasi-contraction.

THEOREM 8.3. *A polynomial diffeomorphism of \mathbb{C}^2 is hyperbolic on J^* (resp. J) if and only if there is a neighborhood \mathcal{N} of J^* (resp. J), and Riemann surface laminations \mathcal{L}^\pm of $\mathcal{N} \cap J^\pm$ such that \mathcal{L}^+ and \mathcal{L}^- intersect transversely at all points of J^* (resp. J).*

Proof. We start by working with J^* . The fact that this lamination structure exists for a hyperbolic set of a diffeomorphism is standard. We will prove the converse. For a saddle point p , it follows from (7) of [BS6, Theorem 2.1] that $W^u(p)$ is a leaf of \mathcal{L}^- . The lamination hypothesis implies that the leaves of \mathcal{L}^- may be written locally as a family of graphs of holomorphic functions. Since bounded analytic functions have locally bounded first derivatives, this implies that the bounded area condition (3.1) holds. For each $p \in J^*$, whether or not p is a saddle, the variety $V^u(p, \epsilon)$ is a manifold which is transversal to \mathcal{L}^+ at p . By Lemma 8.2, $V^u(p, \epsilon)$ intersects $\mathbb{C}^2 - K^+$ arbitrarily close to p . In particular the function G^+ is positive on $V^u(p, \epsilon)$. Compactness of the set of varieties $V^u(p, \epsilon)$ gives a positive lower bound for the maximum of G^+ on $V^u(p, \epsilon)$ which is independent of p . Thus by Theorem 3.4, f is quasi-expanding. By Proposition 5.3, $\mathcal{J}_1 = J^*$. By similar arguments, f^{-1} is quasi-expanding, and $J^* = \mathcal{J}_{1,1}$. By Proposition 8.1, then, J^* is a hyperbolic set for f .

Now let us deal with J . Under our hypotheses the currents μ^\pm supported on J^\pm are given by transverse measures. Thus the wedge product, μ , can be interpreted locally as a product measure. It follows that the support of μ , which

is a priori a subset of J , is actually equal to J . But the support of μ is J^* . According to the previous paragraph, $J = J^*$ is a hyperbolic set for f . \square

Let $\psi = (\psi_1, \psi_2) = (z(\zeta), w(\zeta)): (\mathbf{C}, 0) \rightarrow (\mathbf{C}^2, x)$ be a germ of a holomorphic mapping, and let $V(\psi)$ denote the induced germ at x . Then $V(\psi)$ has a Puiseux representation (7.2) with $j > m$, so that $V(\psi)$ is tangent to the z -axis. Since $V(\psi)$ is locally irreducible at x , we may assume that $\gcd(m, n_1, n_2, \dots) = 1$, where n_i is a listing of all the numbers such that $a_{n_i} \neq 0$.

Let us recall some facts about complex varieties. (See [Ch, §10, §12] for details). For a point $y \in V$, we let $\mu(V, y)$ denote the multiplicity of V at y . This number is defined by the property that for a generic complex line L passing near y , $L \cap V$ contains exactly $\mu(V, y)$ points near y . V is regular at y if and only if $\mu(V, y) = 1$. If V is written as a Puiseux expansion (7.2), with $\gcd(m, n_1, n_2, \dots) = 1$, then any line L transversal to $\{w = 0\}$ and passing near $(0, 0)$ will intersect V in m points near the origin. Thus $\mu(V, x) = m$.

If $\text{Ord}(\psi) = k$, then $\text{Ord}(\psi_1) = k \geq m$, and $\text{Ord}(\psi_2) = kj/m > k$. Let $\xi(\zeta) = \zeta + \dots$ be a germ of a holomorphic function such that $\psi_1(\zeta) = c\xi^k$ near $\zeta = 0$. We may assume that $c = 1$. We may write $\psi_2(\zeta) = \sum c_n \xi^n$. This gives another Puiseux representation for V : $w = \sum c_n z^{n/k}$. On the other hand, the Puiseux representation is essentially unique. So m divides k , and we may set $p := k/m \in \mathbf{Z}$. Thus we may write $\psi(\zeta) = \phi(\xi^p) = (\phi_1(\xi^p), \phi_2(\xi^p))$, where $\phi_1(t) = t^{k/p}$, and $\phi_2(t) = \sum_{n=j}^{\infty} a_n t^{n/p}$, where n is divisible by p whenever $a_n \neq 0$.

To summarize, if $\text{Ord}(\psi) = k > m$, then m divides k , and ψ covers the variety V exactly $p = k/m$ times. The relation between the multiplicity (order) of the parametrizing function and the multiplicity of the variety is thus

$$(8.1) \quad \text{Ord}(\psi) = p \cdot \mu(V, x).$$

In the sequel we will treat $V(\psi)$ as the variety V , but counted with multiplicity p . One reason for introducing multiplicities is that it makes it easier to view varieties as currents: if ϕ_j is a sequence of nonsingular mappings which converge to ϕ in some neighborhood of the origin, then the corresponding germs $V(\phi_j)$ converge as currents (in some neighborhood of x) to the current defined by $V(\psi)$ counted with multiplicity p .

If V_1 and V_2 are 1-dimensional varieties which intersect only at x , we may define $\iota_x(V_1, V_2)$, the intersection number at x . This number has the property that for almost every small $\tau_1, \tau_2 \in \mathbf{C}^2$ the translates $V_j + \tau_j$, $j = 1, 2$, intersect in $\iota_x(V_1, V_2)$ points near x . In general, we have

$$\iota_x(V_1, V_2) \geq \mu_x(V_1)\mu_x(V_2).$$

Equality holds if the tangent cones of V_1 and V_2 at x are distinct. The intersection number behaves continuously: if V_1^j (resp. V_2^j) are sequences of varieties that

converge in the sense of currents to V_1 (resp. V_2), then for $j \geq j_0$, we have

$$\iota_x(V_1^j, V_2^j) = \iota_x(V_1, V_2).$$

Now let $\psi_j, j = 1, 2$ be a germs of a mapping that define the varieties $V_j, j = 1, 2$. If x is an isolated point of intersection of V_1 and V_2 , then

$$(8.2) \quad \begin{aligned} \iota_x(V(\psi_1), V(\psi_2)) &= p_1 p_2 \cdot \iota_x(V_1, V_2) \\ &\geq p_1 p_2 \cdot \mu_x(V_1) \mu_x(V_2) = \text{Ord}(\psi_1) \text{Ord}(\psi_2). \end{aligned}$$

These properties of varieties give us the following:

LEMMA 8.4. *Let $\psi_j: \{|\zeta| < 1\} \rightarrow \mathbf{C}^2, j = 1, 2$ be nonconstant mappings with $\psi_1(0) = \psi_2(0)$. Set $m_j = \text{Ord}(\psi_j)$, and let $r > 0$ be given. Then for $\hat{\psi}_j$ sufficiently close to ψ_j , there are sets $X_j \subset \{|\zeta| < r\}$ such that*

$$\sum_{a \in X_j} \iota(V_1, V_2, \hat{\psi}_j(a)) \cdot \text{Ord}(\hat{\psi}_j, a) \geq m_j,$$

where $\text{Ord}(\hat{\psi}_j, a) = \text{Ord}(\hat{\psi}_j(\zeta - a))$ denotes the order of $\hat{\psi}_j$ at $\zeta = a$.

An important topological dynamical consequence of hyperbolicity is the shadowing property. The following result gives us a quantitative measure of the failure of uniqueness of shadowing.

THEOREM 8.5. *Suppose that f is quasi-expanding and quasi-contracting. If $\mathcal{J}_{j,k} \neq \emptyset$, then for $\epsilon > 0$ there is a set $X \in \mathcal{J}^*$ containing jk elements such that*

$$\sup_{n \in \mathbf{Z}} \max_{a, b \in X} \text{dist}(f^n a, f^n b) < \epsilon.$$

Proof. By hypothesis, there is a point $x \in \mathcal{J}_{j,k}$. Choose $\psi^s \in \Psi_x^s$ with $\text{Ord}(\psi^s) = j$ and $\psi^u \in \Psi_x^u$ with $\text{Ord}(\psi^u) = k$. If $\{p_i\}, \{q_j\} \subset S$ are sequences converging to x with $\phi_{p_i} \rightarrow \psi^s$ and $\phi_{q_i}^u \rightarrow \psi^u$, then by Lemma 6.4 of [BLS], we may assume that $\phi_{p_i}^s(|\zeta| < 1)$ (resp. $\phi_{p_i}^s(|\zeta| < 1)$) intersects $\psi^u(|\zeta| < 1)$ (resp. $\psi^s(|\zeta| < 1)$) transversally.

Let $M = \sup_{\psi \in \Psi} \max_{|\zeta| \leq 1} |\psi'(\zeta)|$, and set $r = \epsilon/M$. Let $X^s, X^u \subset \{|\zeta| < r\}$ be the sets given by Lemma 8.4. Since $\phi_{p_i}^s$ and $\phi_{q_i}^u$ are immersions, the order at each point is equal to 1. And since the immersions are transversal for i sufficiently large, the intersection numbers are 1. Thus each set X^s and X^u contains at least jk points.

Let $X = \{\phi_{p_i}^s(\zeta) : \zeta \in X^s\} = \{\phi_{q_i}^u(\zeta) : \zeta \in X^u\}$. Thus for $n \geq 0$ we have

$$\begin{aligned} \max_{a, b \in X} \text{dist}(f^n a, f^n b) &= \max_{\zeta', \zeta'' \in X^s} \text{dist}(f^n \phi_{p_i}^s(\zeta'), f^n \phi_{p_i}^s(\zeta'')) \\ &= \max_{\zeta', \zeta'' \in X^s} \text{dist}(\phi_{p_i}^s(\lambda_n^s \zeta'), \phi_{p_i}^s(\lambda_n^s \zeta'')) \leq \max_{|\zeta| \leq \kappa^{-n} r} |\phi_{p_i}^s(\zeta)'| \leq \kappa^{-n} r M \leq \epsilon. \end{aligned}$$

For $n \leq 0$, we use $\phi_{q_i}^u$ instead, and we conclude that the diameter of $f^n X$ is no greater than ϵ for all $n \in \mathbf{Z}$. \square

Note that if the varieties V_x^s and V_x^u are tangent, then the set X may be taken to have strictly more than jk elements.

COROLLARY 8.6. *Suppose that f is quasi-expanding and quasi-contracting, but f is not hyperbolic on J^* . Then f is not expansive.*

Proof. If f is not hyperbolic, it follows from Proposition 8.1 that $\mathcal{J}_{j,k} \neq \emptyset$ for some index pair $(j, k) \neq (1, 1)$. By Theorem 8.5, then, f is not expansive. \square

Since hyperbolic mappings are expansive, and expansivity is preserved under topological conjugacy, we have the following.

COROLLARY 8.7. *If f is quasi-expanding and quasi-contracting but not hyperbolic, then f is not topologically conjugate to a hyperbolic map.*

We will use the following result, which is a special case of Proposition 5.1 of [V].

LEMMA 8.8. *Suppose that V is a subvariety of the bidisk $\{|z|, |w| < 1\}$, and suppose that the projection to the z -axis is proper and has degree bounded by $m < \infty$. For any $\epsilon > 0$ there is a $\delta > 0$, depending only on ϵ and m , such that if \tilde{V} is a connected component of $V \cap \{|z| < \delta\}$, then the diameter of \tilde{V} is less than ϵ .*

We refer to $\mathcal{C} := J^* - \mathcal{J}_{1,1}$ as the singular locus of f . In the following results, we consider f for which \mathcal{C} is finite. This is parallel to the critical finiteness condition in one complex dimension. Note that if \mathcal{C} is finite, then \mathcal{C} consists of saddle points, and $\mathcal{V}^{s/u}$ are regular on J^* and form laminations on $\mathcal{J}_{1,1} = J^* - \mathcal{C}$. Further, E^s and E^u are transverse at \mathcal{C} . Thus the set of tangencies, written $\mathcal{T} = \{x \in J^* : E_x^s = E_x^u\}$, is a subset of $\mathcal{J}_{1,1} = J^* - \mathcal{C}$.

PROPOSITION 8.9. *Let f be quasi-expanding and quasi-contracting, and let \mathcal{C} be finite. Then for each tangency $r \in \mathcal{T}$, there are points $p, q \in \mathcal{C}$ such that $r \in W^s(p) \cap W^u(q)$.*

Proof. If $r \in \mathcal{T}$, then $\alpha(r) \subset \mathcal{C}$ by Theorem 7.3. Thus $r \in W^u(q)$ for some $q \in \mathcal{C}$. Similarly, $\omega(r) \subset \mathcal{C}$, so $r \in W^s(p)$ for some $p \in \mathcal{C}$. \square

THEOREM 8.10. *If f is quasi-expanding and quasi-contracting, and if \mathcal{C} is finite, then \mathcal{T} is a discrete subset of $\mathcal{J}_{1,1}$, and the closure of \mathcal{T} is $\mathcal{T} \cup \mathcal{C}$.*

Proof. Since $\mathcal{C} = J^* - \mathcal{J}_{1,1}$ is finite, it consists of periodic points, which must be saddle points by Corollary 6.3. Saddle points are not points of tangency, so $\mathcal{T} \subset \mathcal{J}_{1,1}$. The families of varieties \mathcal{V}^s and \mathcal{V}^u are laminations in a neighborhood of $\mathcal{J}_{1,1}$. Thus any tangency must be isolated by Lemma 6.4 of [BLS].

Now let us fix a saddle point $x \in \mathcal{C}$; and passing to a higher iterate of f , we may assume it is a fixed point. It follows that $x \in \mathcal{J}_{j,k}$ for some index pair $(j, k) \neq (1, 1)$. We may assume that $k > 1$. Consider a coordinate system (z, w) such that $x = (0, 0)$, and f is essentially linear on $\mathcal{B} := \{|z|, |w| < 1\}$, with uniform expansion in the horizontal direction and uniform contraction in the vertical direction. Given $\rho > 0$, we may choose small $r > 0$ and $0 < \rho_1 < \rho_2 < 1$ such that for any point q of $\{|z| < 1, |w| < r\}$ there is an $n > 0$ such that $f^{-n}q$ belongs to $S := \{|z| < \rho, \rho_1 < |w| < \rho_2\}$. For ρ, ρ_2 and \mathcal{B} , let $\mathcal{V}^s(\mathcal{B})$ and $\mathcal{V}^u(\mathcal{B})$ denote the set of varieties in \mathcal{B} corresponding to $V^{s/u}(x)$ for $x \in \{|z| < \rho, |w| < \rho_2\}$. We will choose ρ, ρ_2 and \mathcal{B} small enough that for $x \in \mathcal{J}^* \cap \{|z| < \rho, |w| < \rho_2\}$, V_x^u is a subvariety of $\{|z| < 1, |w| < 1\}$, with proper projection to the z -axis and a uniform bound on the mapping degree of the projection.

Let us choose $\psi \in \Psi_x^{k,u}$, and let $\{p_i\} \subset S$ be a sequence such that ϕ_{p_i} converges to ψ . For i sufficiently large, we have $V(p_i) \subset \{|z| < 1, |w| < r\}$, and we may choose the first n_i such that $f^{-n_i}V^u(p_i) \cap S \neq \emptyset$. Let us choose a subsequence of $\{\tilde{f}^{-n_i}\psi_{p_i}\}$ which converges to a limit $\tilde{\psi} \in \Psi_y$ for some y in the closure of S . Since $V^u(y) \neq V^u(x)$, it follows that $y \in \mathcal{J}_{*,1}$.

Given $\epsilon > 0$, let us choose $\delta > 0$ as in Lemma 8.8. For i sufficiently large, $\tilde{V}_i := V^u(p_i) \cap \{|z| < \delta\}$ is connected. Since n_i was chosen for the first time $f^{-n_i}V_i$ intersects S , it follows that $f^{-n_i}\tilde{V}_i \subset \mathcal{B}$. Since f is contracting in the z -direction, it follows that the projection of $f^{-n_i}\tilde{V}_i$ to the z -axis has diameter less than δ . By Lemma 8.8, then the diameter of $f^{-n_i}\tilde{V}_i$ is less than ϵ .

To see that $V(y)$ intersects $W_{loc}^s(p)$ tangentially, we recall that $V^u(\psi_{p_i}) \cap V^s(x) \cap \mathcal{B}$ consists of k points, which are also contained in $f^{-n_i}\tilde{V}_i$. By Lemma 8.8, the set of intersection has diameter no greater than $\epsilon > 0$. Since these points remain inside a compact subset of \mathcal{B} , it follows that the intersection multiplicity of $V^u(y)$ and $W_{loc}^s(p)$ is also k , and the diameter of the set of intersection is $\leq \epsilon$. Since ϵ may be taken arbitrarily small, $V^u(y)$ intersects $W_{loc}^s(p)$ in a single point of multiplicity k . Since $k > 1$, this is a tangency. \square

Taking into account the multiplicity k in the last paragraph of this proof, we have the following.

COROLLARY 8.11. *Suppose that f is quasi-expanding and quasi-contracting but is not hyperbolic. If \mathcal{C} is finite, then $\mathcal{C} \neq \emptyset$, and there are points of tangency. More precisely, if $p \in \mathcal{J}_{j,k}$, $k > 1$, then there is a point $y \in W^s(p)$ where $W^u(y)$ is tangent to $W^s(p)$, and the order of contact is k . Conversely, if $y \in W^s(p)$ is a point of tangency between $W^s(p)$ and $W^u(y)$, then the order of contact is no greater than k .*

A. Appendix: One-dimensional mappings. In this paper we have developed an approach to the study of a dynamically well-behaved family of maps of \mathbf{C}^2 via a family of immersions from \mathbf{C} into \mathbf{C}^2 . In this Appendix we explore a similar approach to one-dimensional mappings. Our purpose is to justify the

analogy between semi-hyperbolicity in \mathbf{C} and quasi-hyperbolicity in \mathbf{C}^2 . This is achieved in Theorem A.5.

Let us consider a polynomial mapping $g: \mathbf{C} \rightarrow \mathbf{C}$ of degree $d > 1$. Let $J = J_g$ denote the Julia set, and let $K = K_g$ denote the filled Julia set, so $J = \partial K$. Let $G = G_K$ denote the Green function of $\mathbf{C} - K$ with pole at infinity. Let $S \subset J$ denote the set of repelling periodic points. For each $x \in S$ we let n denote the period of x , so that $g^n x = x$. We define $\lambda(x, n) := g^n(x)'$ and $L_n(\zeta) = \lambda(x, n)\zeta$. There is a (linearizing) function $\phi_x: \mathbf{C} \rightarrow \mathbf{C}$ such that

$$(A.1) \quad \phi_x(0) = x, \text{ and } g^n \circ \phi_x(\zeta) = \phi_x(\lambda(x, n)\zeta) = \phi_x \circ L_n(\zeta)$$

(see Milnor [M]). The linearizing function is the analog of the unstable manifold, and the functional equation is the analogue of (1.4). The function ϕ_x also satisfies

$$(A.2) \quad \phi_x = g^n \circ \phi_x \circ L_n^{-1} = g^{jn} \circ \phi_x \circ L_n^{-j}$$

for every $j \geq 0$. If $\phi'_x(0) = 1$, we may define ϕ_x simply as

$$(A.3) \quad \phi_x(\zeta) = \lim_{j \rightarrow \infty} g^{nj} \circ L_n^{-j}.$$

For $k \geq 0$, $g^k \phi_x: (\mathbf{C}, 0) \rightarrow (\mathbf{C}, g^k x)$ is a linearizing function at $g^k x$. For $\alpha \in \mathbf{C}$, $\alpha \neq 0$, $\phi_x(\alpha\zeta)$ is also a linearizing function. We fix $0 < t < \infty$, and we define ψ_x to be the linearizing function $\psi_x: \zeta \mapsto \phi_x(\alpha\zeta)$, with $|\alpha|$ determined by condition (4.8). Thus we have a family of maps $\psi_S = \{\psi_x : \mathbf{C} \rightarrow \mathbf{C} : x \in S\}$.

As in Section 1 we may take normal limits and obtain the family Ψ , where each $\psi \in \Psi_x$ is defined and holomorphic on a domain Ω_x with $\{|\zeta| < 1\} \subset \Omega_x \subset \mathbf{C}$. We may define the transformation $\tilde{g} : \Psi_x \rightarrow \Psi_{g^k x}$ as in Section 1, and if ψ_x is nonconstant, we may define the multiplier $\lambda = \lambda_{\psi_x}$ by the condition $\tilde{g}(\psi_x)(\zeta) = \psi_{g^k x}(\lambda^{-1}\zeta)$.

We will say that g is *quasi-expanding* if Ψ is a normal family of entire functions. By Proposition 4.7, quasi-hyperbolicity is independent of normalizing constant t ; it will be convenient for us to choose a specific value of t just before Lemma A.4. By Proposition 1.5, quasi-expansion implies that (\ddagger) holds at each $x \in J$. By Theorem 1.2, it is equivalent to $|\lambda_x| \geq \kappa > 1$ for all $x \in S$.

If g is quasi-expanding, we define τ as was done just before Proposition 5.1. There is a natural stratification $J = \mathcal{J}_1 \sqcup \dots \sqcup \mathcal{J}_k$, where $\mathcal{J}_m = \{\tau = m\}$. We define the infinitesimal metric $\|\cdot\|_x^\#$ on the tangent space $T_x \mathbf{C}$ for $x \in \mathcal{J}_i$ as in Section 6. Note that $x \mapsto \|\cdot\|_x^\#$ is not globally continuous, but it is continuous on each stratum \mathcal{J}_i . This metric is uniformly expanded by g' . And as in Corollary 6.3, there is a $\kappa > 1$ such that $|g^n(x)'| > \kappa^n$ holds for each point of period n . While it was known earlier that a semi-hyperbolic map has a (singular) metric which is uniformly expanded (see [Ca]), this construction for quasi-expanding maps seems more direct, in addition to defining an (infinitesimal) metric at each point of J .

Let $\mathcal{C} = \{z \in \mathbf{C} : g'(z) = 0\}$ denote the set of critical points of g . For $c \in \mathcal{C}$, let $\mathcal{P}(c) = \{g^j(c) : j \geq 1\}$, let $\mathcal{P}(\mathcal{C}) = \bigcup_{c \in \mathcal{C}} \mathcal{P}(c)$, and let $\bar{\mathcal{P}}(c)$ denote the closure of $\mathcal{P}(c)$.

LEMMA A.1. *If $c \in \mathcal{C}$ be a critical point, then $\tau \geq 2$ on $\bar{\mathcal{P}}(c)$. If $c \in \omega(c)$, then $\tau = \infty$ on $\omega(c)$.*

Proof. If $\psi \in \Psi_c$ is constant, then $\tilde{g}^j(\psi) \in \Psi_{g^j c}$ is constant. Thus $\tau(g^j c) = \infty$ for all $j \geq 0$. Since τ is upper semicontinuous, it is equal to ∞ on the closure of $\{g^j(c) : j \geq 1\}$. Now let $\psi \in \Psi_c$ be a nonconstant function. It follows that $\tilde{g}^j(\psi)$ has a critical point at the origin for $j \geq 1$, i.e., $\tau > 1$ on $\{g^j(c) : j \geq 1\}$. Again, by upper semicontinuity, $\tau > 1$ on the closure of this set.

Now suppose that $c \in \omega(c)$. If Ψ_c consists only of the constant function, then $\tau(c) = \infty$. If there is a nonconstant $\psi \in \Psi_c$, then $\text{Ord}(\psi) < \infty$. Let $n_j \rightarrow \infty$ be a sequence such that $g^{n_j} c \rightarrow c$. By the chain rule, $\text{Ord}(\tilde{g}^{n_j} \psi) > \text{Ord}(\psi)$. Passing to a subsequence of $\{n_j\}$, we may assume that $\tilde{g}^{n_j} \psi \rightarrow \hat{\psi}$. By the upper semicontinuity of τ , we have $\text{Ord}(\hat{\psi}) > \text{Ord}(\psi)$. Thus $\tau(c) = \infty$. \square

We let $\mathcal{C}'_x := \{\zeta \in \mathbf{C} : \psi'_x(\zeta) = 0\}$ denote the set of critical points of ψ_x .

LEMMA A.2. *If $x \in S$ is a repelling periodic point, then $\psi_x(\mathcal{C}'_x) \subset \mathcal{P}(\mathcal{C})$.*

Proof. Suppose $\zeta \in \mathcal{C}'_x$. Since x is a repelling periodic point, $|\lambda(x, n)| > 1$, so it follows from (A.1) that $\psi'_x(0) \neq 0$. Let U be a neighborhood of the origin in \mathbf{C} where $\psi'_x \neq 0$. Choose j such that $\tilde{\zeta} = L_n^{-j} \zeta \in U$, and set $\tilde{z} = \psi_x(\tilde{\zeta})$. By (A.2) and the Chain Rule,

$$\psi'_x(\zeta) = (g^{jn} \circ \psi_x \circ L^{-j}(\zeta))' = g'(g^{jn-1}(\tilde{z})) \cdots g'(g(\tilde{z})) \cdot g'(\tilde{z}) \cdot (\psi_x \circ L^{-j})'(\zeta) = 0.$$

It follows $g'(g^k \tilde{z}) = 0$ for some $1 \leq k \leq jn - 1$, which means that $g^k \tilde{z} \in \mathcal{C}$. Thus $\psi_x(\zeta) = g^{jn-k}(g^k \tilde{z}) \in \mathcal{P}(\mathcal{C})$. \square

PROPOSITION A.3. *If g is quasi-expanding, then $\mathcal{J}_1 = J - \bar{\mathcal{P}}(\mathcal{C})$.*

Proof. By Lemma A.1, \mathcal{J}_1 is disjoint from $\bar{\mathcal{P}}(\mathcal{C})$. Conversely, let $y \notin \bar{\mathcal{P}}(\mathcal{C})$ be given. Choose $0 < \delta < \text{dist}(y, \bar{\mathcal{P}}(\mathcal{C}))$. Let x be a repelling periodic point sufficiently close to y that $B(x, \delta) \cap \bar{\mathcal{P}}(\mathcal{C}) = \emptyset$. By Lemma A.2, there are no critical values of ψ_x in the disk $B(x, \delta)$. Thus there is an analytic function $\phi: B(x, \delta) \rightarrow \mathbf{C}$ such that $\psi \circ \phi(z) = z$. By the Koebe Distortion Theorem, $\{|\zeta| < \delta|\phi'(x)|/4\} \subset \phi(B(x, \delta))$.

Now let $\chi(x) = \inf\{|\zeta| \in \mathcal{C}'_x\}$. Since $\phi(B(x, \delta)) \cap \mathcal{C}'_x = \emptyset$, we have $\delta|\phi'(x)|/4 \leq \chi(x)$, or $\delta/4 \leq \chi(x)|\psi'_x(0)|$. Since $|\psi'_x(0)|$ is bounded above, it follows that $\chi(x)$ is bounded below.

To show that $y \in J_1$, we need to show that $\psi'_y(0) \neq 0$ for every $\psi_y \in \Psi_y$. Let us take a sequence $x \rightarrow y$, such that $\psi_x \rightarrow \psi_y$. Since $\chi(x)$ is bounded below, there is an open neighborhood U of the origin in \mathbf{C} where $\psi'_x \neq 0$ on U for all x .

The limit ψ'_y is then either nonvanishing on U , or it vanishes identically. By (\ddagger) , then, ψ'_y does not vanish on U . \square

For a domain D and $y \in g^{-n}D$, we let $(g^{-n}D)_y$ denote the connected component of $g^{-n}D$ containing y . A mapping g is said to be *semi-hyperbolic* (see [CJY]) if there are numbers $\epsilon_0 > 0$ and $M < \infty$ such that for every $n \geq 0$, $0 < \epsilon < \epsilon_0$ and $x \in J$, the mapping degree of

$$g|(g^{-n}B(x, \epsilon))_y : (g^{-n}B(x, \epsilon))_y \rightarrow B(x, \epsilon)$$

is bounded by M for each $y \in g^{-n}x$. If g is semi-hyperbolic, then by the two left-hand containments in Theorem 3.2, there is an $a > 0$ such that for $\rho_1 > 0$ sufficiently small, depending only on M , such that for all $x \in J$, all $n \geq 0$, and all $y \in g^{-n}x$, we have

$$B(y, as) \subset (g^{-n}B(x, \rho_1\epsilon))_y \subset B(y, s)$$

for some $s > 0$. Set

$$t := \min_{x \in J} \max_{B(x, \rho_1\epsilon)} G.$$

LEMMA A.4. *Let g be semi-hyperbolic, and let $\epsilon, \rho_1, t, a > 0$ and $M < \infty$ be as above. Then there is a number $B < \infty$ such that for any periodic point x , $\omega_x := (\psi_x^{-1}B(x, \rho_1\epsilon))_0$ satisfies*

$$\{|\zeta| < B^{-1}\} \subset \omega_x \subset \{|\zeta| < B\}$$

and $\psi_x: \omega_x \rightarrow B(x, \epsilon)$ is a proper mapping of degree $\leq M$.

Proof. Let n denote the period of x , and assume that $x = 0$. For $0 < \rho < 1$, let $\bar{t} := \max_{x \in J} \max_{B(x, \rho_1\epsilon)} G$. Choose ρ small enough that $\bar{t} < t$.

For each $j \geq 0$ we have $\{|\zeta| < ar\} \subset \omega \subset \{|\zeta| < r\}$ for some $r = r_j$ corresponding to $\omega = (L_n^j g^{-jn} B(0, \rho\rho_1\epsilon))_0$ and for some $r = \tilde{r}_j$ corresponding to $\omega = (L_n^j g^{-jn} B(0, \rho_1\epsilon))_0$. We may take the limit as $j \rightarrow \infty$ in (A.3) so that $g^{jn} \circ L_n^{-j} \rightarrow \phi_x$, and we may pass to a subsequence to have $r_j \rightarrow r$ and $\tilde{r}_j \rightarrow \tilde{r}$. If we write $\tilde{\omega}'_x = (\phi_x^{-1} B(0, \rho_1\epsilon))_0$ and $\omega'_x = (\phi_x^{-1} B(0, \rho\rho_1\epsilon))_0$, then we have $\{|\zeta| < r\} \subset \omega'_x \subset \{|\zeta| < r\}$ and $\{|\zeta| < \tilde{r}\} \subset \tilde{\omega}'_x \subset \{|\zeta| < \tilde{r}\}$. Thus

$$\tilde{\omega}'_x - \omega'_x \subset \{ar < |\zeta| < \tilde{r}\}.$$

Thus the moduli satisfy

$$\log(\tilde{r}/(ar)) \leq \text{Mod}(\{ar < |\zeta| < \tilde{r}\}) \leq \text{Mod}(\tilde{\omega}'_x - \omega'_x).$$

Let us remark that $\phi_x: (\phi_x^{-1}B(0, \epsilon))_0 \rightarrow B(0, \epsilon)$ is a proper mapping with degree bounded by M since each $g^{jn} \circ L_n^{-j}$ was also a proper mapping with degree bounded by M . It follows that $\phi_x: (\tilde{\omega}'_x - \bar{\omega}'_x) \rightarrow (B(x, \rho_1\epsilon) - \bar{B}(x, \rho_1\epsilon))$ is a proper map. The modulus of an annulus is defined as the extremal length of the family of curves connecting the two boundaries (cf. [A, Chapter 4]). Under a proper map, this family pulls back to a family of curves which connect the two boundaries; thus the modulus cannot decrease, so we have

$$\text{Mod}(\tilde{\omega}'_x - \bar{\omega}'_x) \leq \text{Mod}(B(x, \rho_1\epsilon) - \bar{B}(x, \rho_1\epsilon)) = \log(1/\rho).$$

We conclude that $\tilde{r}/(ar) \leq \rho^{-1}$.

Finally, let us consider ψ_x and ω_x , which are obtained from ϕ_x and $\tilde{\omega}'_x$ by a scaling by a linear factor $\lambda > 0$. Thus $\{|\zeta| < \lambda ar\} \subset \omega_x = \lambda\tilde{\omega}'_x \subset \{|\zeta| < \lambda\tilde{r}\}$. By the definition of t , we have $\max_{B(x, \rho_1\epsilon)} G = \max_{\omega_x} G \geq t$. By the Maximum Principle, we have $\max_{|\zeta| < \lambda\tilde{r}} G \geq t$. It follows by (4.8) that $\lambda\tilde{r} \geq 1$. Similarly, we have $\max_{B(x, \rho_1\epsilon)} G = \max_{\lambda\omega'_x} G \leq \tilde{t} < t$. Again by the Maximum Principle, $\max_{|\zeta| < \lambda ar} G \leq \tilde{t}$. Thus by (4.8) we have $ar\lambda < 1$. By our previous inequality, it follows that $\rho \leq \lambda ar \leq \lambda\tilde{r} \leq \rho^{-1}$, so we may take $B = \rho^{-1}$.

Finally, the mapping degree of the restriction of ψ_x to $(\psi_x^{-1}B(0, \epsilon))_0$ is the same as the degree of restriction of ϕ_x , so it is bounded by M . □

We will use the following estimate on the Green function (see [CJY, §3]): *If g is semi-hyperbolic, then there exist $\eta > 0$ and $A < \infty$ such that*

$$(A.4) \quad \max_{B(x,r)} G \geq \eta r^A$$

for all $x \in J$, $0 < r < 1$. Note that (1.12) and (A.4) are similar but different; the estimate (A.4) takes place on dynamical space while (1.12) concerns the uniformizations.

THEOREM A.5. *Quasi-expansion \Leftrightarrow semi-hyperbolicity.*

Proof. Suppose first that g is quasi-expanding. By Corollary 6.3, any periodic point is expanding. Thus there are no parabolic points. Now suppose that $c \in J$ is a critical point. By quasi-expansion, we must have $\tau < \infty$ on J , so by Lemma A.1 this means that c is not contained in $\omega(c)$, its ω -limit set. It follows by [CJY, Theorem 1.1] that g is semi-hyperbolic

Now suppose that g is semi-hyperbolic. Let B be as in Lemma A.4, and choose $\chi > B^2$. By Theorem 3.2, we may choose $\rho_2 > 0$ sufficiently small that for any $y \in J$ there is a number $s = s_y$ such that

$$(\psi_y^{-1}(B(y, \rho_2\rho_1\epsilon))_0 \subset \{|\zeta| < s\} \subset \{|\zeta| < \chi s\} \subset (\psi_y^{-1}(B(y, \rho_1\epsilon)))_y.$$

By the right-hand inclusion in Lemma A.4, we have $\chi s < B$.

Let us set

$$\bar{t}_1 := \max_{x \in J} \max_{B(x, \rho_1 \epsilon)} G.$$

Choose k such that

$$\left(\frac{\bar{t}_1 d^{-k}}{\eta} \right)^{1/A} \leq a \rho_2 \rho_1 \epsilon.$$

By Theorem 3.2, there is an $r > 0$ such that $B(y, ar) \subset (g^{-k}(B(x, \rho_1 \epsilon)))_y \subset B(y, r)$ for $y \in g^{-k}x$. By the definition of \hat{t}_1 and the maximum principle, we have that $G \leq \hat{t}_1 d^{-k}$ on $B(y, ar)$. It follows from (A.4) that

$$\bar{t}_1 d^{-k} \geq \eta (ar)^A.$$

By the choice of k we conclude that $r \leq \rho_2 \rho_1 \epsilon$. Thus

$$\psi_y^{-1}(g^{-k}(B(x, \rho_1 \epsilon)))_0 \subset (\psi_y^{-1}B(x, \rho_2 \rho_1 \epsilon))_0 \subset \{|\zeta| < s\}$$

with s as above.

Let $L: \zeta \mapsto \lambda \zeta$ denote the linear map such that $g^k \circ \psi_y = \psi_x \circ L$. By this functional equation, L maps $(\psi_y^{-1}g^{-k}B(x, \rho_1 \epsilon))_0 \subset \{|\zeta| < s\}$ to $(\psi_x^{-1}B(x, \rho_1 \epsilon))_0$. This last set contains $\{|\zeta| < 1/B\}$ by the left-hand containment in Lemma A.4. Thus $\lambda \geq (sB)^{-1}$, which is no smaller than χB^{-2} since $\chi s < B$. We conclude that $|\lambda|$ is uniformly bounded below by $\kappa := \chi B^{-2} > 1$, so by Theorem 1.2, g^k is quasi-expanding. By Proposition 1.3, then, g is quasi-expanding. \square

A consequence of Corollary 6.3 is:

COROLLARY A.6. *If g is semi-hyperbolic, then the repelling periodic points are uniformly repelling.*

Questions dealt with in this Appendix also arise naturally in connection with the study of the structure of leaves in the induced inverse limit system. See [LM] for this approach.

DEPARTMENT OF MATHEMATICS, INDIANA UNIVERSITY, BLOOMINGTON, IN 47405

DEPARTMENT OF MATHEMATICS, CORNELL UNIVERSITY, ITHACA, NY 14853

REFERENCES

-
- [A] L. Ahlfors, *Conformal Invariants*, McGraw-Hill, New York, 1973.
- [BLS] E. Bedford, M. Lyubich, and J. Smillie, Polynomial diffeomorphisms of \mathbf{C}^2 . IV: The measure of maximal entropy and laminar currents, *Invent. Math.* **112** (1993), 77–125.
- [BS1] E. Bedford and J. Smillie, Polynomial diffeomorphisms of \mathbf{C}^2 : Currents, equilibrium measure, and hyperbolicity, *Invent. Math.* **87** (1990), 69–99.
- [BS6] ———, Polynomial diffeomorphisms of \mathbf{C}^2 . VI: Connectivity of J , *Ann. of Math.* **148** (1998), 695–735.
- [BS7] ———, Polynomial diffeomorphisms of \mathbf{C}^2 . VII: Hyperbolicity and external rays, *Ann. Sci. Ecole Norm. Sup.* **32** (1999), 455–497.
- [BS] ———, Real polynomial diffeomorphisms with maximal entropy: Tangencies, math DS/0103038.
- [Ca] J. Carette, Liens entre la géométrie et la dynamique des ensembles de Julia, thèse, Univ. de Paris-Sud, Orsay, 1997.
- [CJY] L. Carleson, P. Jones, and J.-C. Yoccoz, Julia and John, *Bol. Soc. Brasil Mat.* **25** (1994), 1–30.
- [Ch] E. Chirka, *Analytic Sets*, Kluwer, Boston, 1989.
- [FS] J.-E. Fornæss and N. Sibony, Complex dynamics in higher dimensions, *Complex Potential Theory* (P. Gauthier and G. Sabidussi, eds.), Kluwer, Boston, 1994, pp. 131–186.
- [F] W. H. J. Fuchs, *Topics in the Theory of Functions of One Complex Variable*, van Nostrand, Princeton, 1967.
- [HO] J. H. Hubbard and R. Oberste-Vorth, Hénon mappings in the complex domain II: Projective and inductive limits of polynomials, *Real and Complex Dynamical Systems* (B. Branner and P. Hjorth, eds.), Kluwer, Boston, 1995, pp. 89–132.
- [LS] F. Ledrappier and J.-M. Strelcyn, A proof of the estimation from below in Pesin’s entropy formula, *Ergodic Theory Dynam. Systems* **2** (1982), 203–219.
- [LM] M. Lyubich and Y. Minsky, Laminations in holomorphic dynamics, *J. Differential Geom.* **47** (1997), 17–94.
- [M] J. Milnor, *Dynamics in One Complex Variable: Introductory Lectures*, Vieweg, Braunschweig, 1999.
- [S] Z. Słodkowski, Holomorphic motions and polynomial hulls, *Proc. Amer. Math. Soc.* **111** (1991), 347–355.
- [V] K. Verma, Boundary regularity of correspondences in \mathbf{C}^2 , *Math. Z.* **231** (1999), 253–299.