



### DOMAIN PROTOCOL

Neurally Adjusted Ventilatory Assist (NAVA) in the adult critical care unit: A randomised, parallel group, allocation concealed, controlled, open, phase 3 pragmatic clinical and cost-effectiveness trial with internal pilot: The UK NAVA Trial

### CONFEDERATION MASTER PROTOCOL

Confederation of Respiratory Critical Care Trials (CoReCCT)

ISRCTN	30709760
Sponsor:	University of Warwick
Funding Body:	NIHR, HTA programme
Ethics Approval date:	07 <sup>th</sup> October 2024
Version	4
Date:	5 <sup>th</sup> February 2026
Stage:	Final

This protocol has regard for current Health Research Authority guidance and content.

#### Protocol Amendments

Amendment Number	Amendment Date	Approval Date
1 (V2.0 07Mar2025)	07May2025 (SA005)	20May2025
2 (V3.0 11Jun2025)	23Jun2025 (NSA12)	23Jun2025
3 (V4.0 05Feb2026)	28Apr2026 (SA007)	21May2026

## CONTACTS

---

### **Sponsor**

University of Warwick  
Research and Impact Services  
University of Warwick  
Gibbet Hill Road  
Coventry  
CV4 8UW  
Telephone: 02476 575 733  
Email: [sponsorship@warwick.ac.uk](mailto:sponsorship@warwick.ac.uk)

### **Chief investigator**

Name: Dr Daniel Hadfield  
Address: Department of Critical Care  
King's College Hospital NHS Foundation Trust  
London, SE5 9RS, UK  
Telephone: 02032991038  
Email: [daniel.hadfield@nhs.net](mailto:daniel.hadfield@nhs.net)

### **Co-chief investigator**

Name: Dr Phil Hopkins  
Address: Department of Critical Care  
King's College Hospital NHS Foundation Trust  
London, SE5 9RS, UK  
Telephone: 02032991038  
Email: [p.hopkins@nhs.net](mailto:p.hopkins@nhs.net)

### **Co-investigators**

Name: Prof Louise Rose  
Address: King's College London, London, UK  
Email: [louise.rose@kcl.ac.uk](mailto:louise.rose@kcl.ac.uk)

Name: Prof Gavin Perkins  
Address: WMS - Warwick Clinical Trials Unit, University of Warwick, Warwick, UK  
Email: [g.d.perkins@warwick.ac.uk](mailto:g.d.perkins@warwick.ac.uk)

Name: Prof Gary Mills  
Address: Sheffield Teaching Hospitals NHS Foundation Trust, Sheffield, UK  
Email: [g.h.mills@sheffield.ac.uk](mailto:g.h.mills@sheffield.ac.uk)

Name: Prof Luigi Camporota  
Address: Guy's and St Thomas' NHS Foundation Trust, London, UK  
Email: [luigi.camporota@gstt.nhs.uk](mailto:luigi.camporota@gstt.nhs.uk)

Name: Prof Danny McAuley  
Address: Wellcome-Wolfson Institute for Experimental Medicine, Queen's University of  
Belfast, Belfast, UK  
Email: [d.f.mcauley@qub.ac.uk](mailto:d.f.mcauley@qub.ac.uk)

Name: Prof Bronwen Connolly  
Address: Wellcome-Wolfson Institute for Experimental Medicine, Queen's University of  
Belfast, Belfast, UK

Email: b.connolly@qub.ac.uk

Name: Prof Nicholas Hart

Address: Guy's and St Thomas' NHS Foundation Trust, London, UK

Email: Nicholas.hart@gstt.nhs.uk

Name: Dr Reinout Mildner

Address: Birmingham Children's Hospital, Birmingham, UK

Email: reinout.mildner@nhs.net

Name: Prof Gerrard Rafferty

Address: King's College London, London, UK

Email: gerrard.rafferty@kcl.ac.uk

### **Patient Investigator**

Name: Chantal Davies

Email: chantaljdavies@yahoo.co.uk

### **Statisticians**

Name: Prof Ranjit Lall

Address: WMS - Warwick Clinical Trials Unit, University of Warwick, Warwick, UK

Email: r.lall@warwick.ac.uk

Name: Dr Chen Ji

Address: WMS - Warwick Clinical Trials Unit, University of Warwick, Warwick, UK

Email: [C.Ji.3@warwick.ac.uk](mailto:C.Ji.3@warwick.ac.uk)

Name: Katie Booth

Address: WMS - Warwick Clinical Trials Unit, University of Warwick, Warwick, UK

Email: [k.booth@warwick.ac.uk](mailto:k.booth@warwick.ac.uk)

Name: Angela Noufaily

Address: WMS - Warwick Clinical Trials Unit, University of Warwick, Warwick, UK

Email: a.noufaily@warwick.ac.uk

### **Health Economists**

Name: Dr Huajie Jin

Address: King's College London, London, UK

Email: huajie.jin@kcl.ac.uk

### **Nurse educator**

Name: Louise Payne

Address: King's College Hospital NHS Foundation Trust, London, UK

Email: louise.payne31@nhs.net

### **Trial Steering Committee:**

The TSC members and contact details are listed in the CoReCCT Master Protocol as an overarching TSC for CoReCCT.

### **Data Monitoring Committee:**

The DMC members and contact details are listed in the CoReCCT Master Protocol as an overarching TSC for CoReCCT.



## Signature page

---

The Chief Investigator and the R&D (sponsor office) have discussed this protocol. The investigators agree to perform the investigations and to abide by this protocol.

The investigator agrees to conduct the trial in compliance with the approved protocol, Good Clinical Practice, the UK GDPR, the Trust Information Governance Policy (or other local equivalent), the Research Governance Framework for Health and Social Care (2005 2<sup>nd</sup> Edition), the Sponsor's SOPs, and other regulatory requirements as amended.

### **Lead Chief investigator**

---

Signature

Date

### **Co-Chief investigator**

---

Signature

Date

## CONTENTS

---

<b>Contacts</b> .....	<b>2</b>
<b>Signature page</b> .....	<b>5</b>
<b>Contents</b> .....	<b>6</b>
<b>Tables</b> .....	<b>8</b>
<b>Figures</b> .....	<b>8</b>
<b>1 Trial summary</b> .....	<b>10</b>
<b>Abbreviations / glossary</b> .....	<b>13</b>
<b>2 Background</b> .....	<b>14</b>
<b>2.1 Epidemiology and burden of the condition</b> .....	<b>14</b>
<b>2.2 Existing knowledge</b> .....	<b>14</b>
<b>2.3 Pilot feasibility trial and surveys</b> .....	<b>14</b>
<b>2.4 Research Question</b> .....	<b>15</b>
<b>2.5 Need for a trial</b> .....	<b>15</b>
<b>2.6 Confederation of Respiratory Critical Care Trials</b> .....	<b>16</b>
<b>3 Trial design</b> .....	<b>16</b>
<b>3.1 Trial summary and flow diagram</b> .....	<b>16</b>
<b>3.2 Trial Setting</b> .....	<b>18</b>
<b>3.3 Internal Pilot</b> .....	<b>18</b>
<b>3.4 Aims, objectives and endpoints</b> .....	<b>19</b>
3.4.1 Primary objective and outcome.....	19
3.4.2 Secondary objectives and outcomes .....	19
3.4.3 Cost-effectiveness objective .....	20
<b>3.5 Trial participants</b> .....	<b>20</b>
3.5.1 Inclusion criteria .....	20
3.5.2 Exclusion criteria .....	20
<b>3.6 Screening</b> .....	<b>21</b>
<b>3.7 Consent</b> .....	<b>21</b>
<b>3.8 Randomisation</b> .....	<b>21</b>
<b>3.9 Post-randomisation withdrawals, exclusions and moves out of region</b> .....	<b>21</b>

3.10	Co-enrolment .....	22
3.11	Measures to avoid bias .....	22
3.12	Site staff training .....	23
<b>4</b>	<b>Interventions .....</b>	<b>23</b>
<b>4.1</b>	<b>Intervention arm (NAVA Technology) .....</b>	<b>23</b>
4.1.1	Component 1: EDi Signal acquisition and optimisation .....	24
4.1.2	Component 2: NAVA monitoring .....	26
4.1.3	Component 3: The NAVA mode .....	26
4.1.4	NAVA Technology training .....	27
<b>4.2</b>	<b>Standard care arm .....</b>	<b>27</b>
<b>4.3</b>	<b>Both groups .....</b>	<b>27</b>
4.3.1	Ventilator weaning .....	27
4.3.2	Standard indications to increase ventilation support during weaning .....	27
4.3.3	Extubation .....	27
4.3.4	Other Clinical Management .....	27
<b>4.4</b>	<b>Intervention duration .....</b>	<b>28</b>
<b>4.5</b>	<b>INTERVENTION ADHERENCE AND CROSSOVER .....</b>	<b>28</b>
<b>5</b>	<b>Assessments and data collection .....</b>	<b>28</b>
5.1	Trial procedures schedule .....	28
5.2	Follow up procedures .....	29
<b>6</b>	<b>Safety and adverse events .....</b>	<b>29</b>
6.1	Pre-specified complications .....	29
6.2	Expected events .....	30
6.3	Reporting Responsibilities summary .....	30
<b>7</b>	<b>Data management .....</b>	<b>31</b>
7.1	Data collection and management .....	31
7.2	Data shared with third parties .....	31
7.3	Archiving .....	31
<b>8</b>	<b>Statistics and health economics .....</b>	<b>31</b>
8.1	Sample size calculation .....	31

8.2	Statistical analysis .....	31
8.3	Sub-groups.....	32
8.4	Futility analyses.....	32
8.5	Health Economic Evaluation.....	32
9	<i>Protocol compliance</i> .....	33
10	<i>Sub-study</i> .....	33
11	<i>Dissemination and publication</i> .....	34
12	<i>Trial organisation and oversight</i> .....	34
12.1	Sponsor and governance arrangements.....	34
12.2	Ethical approval.....	34
12.3	Trial Registration .....	34
12.4	Notification of serious breaches to GCP and/or trial protocol.....	34
12.5	Indemnity .....	34
12.6	Trial timetable and milestones.....	34
12.7	Administration .....	35
12.8	Trial Management Group (TMG) .....	35
12.9	Trial Steering Committee (TSC).....	35
12.10	Data Monitoring Committee (DMC).....	35
12.11	Essential Documentation .....	35
12.12	Financial Support.....	35
12.13	Safeguarding Researchers and Research Participants.....	35
13	<i>References</i> .....	36

## TABLES

---

Table 1.	Trial summary.....	10
Table 2.	Abbreviations / glossary.....	13
Table 3.	Internal pilot outcomes.....	18

## FIGURES

---

Figure 1.	Trial flow diagram .....	16
-----------	--------------------------	----

Figure 2. NAVA system components.....24  
Figure 3. Correct NAVA Catheter position .....25

# 1 TRIAL SUMMARY

Table 1. Trial summary

Master protocol title	CoReCCT - Confederation of Respiratory Critical Care Trials
Domain protocol title	Neurally Adjusted Ventilatory Assist (NAVA) Technology (diaphragm monitor and NAVA mode) vs conventional invasive mechanical ventilation (IMV) for patients at risk of difficult or prolonged weaning from IMV: The UK NAVA Trial
Short title/acronym	UK NAVA
Clinical phase	Phase 3 effectiveness & cost-effectiveness
Purpose of research	To investigate, using a multi-centre, parallel group, pragmatic, randomised controlled trial design, the clinical and cost effectiveness of Neurally Adjusted Ventilatory Assist (NAVA) Technology compared to conventional IMV in adult patients with risk factors for difficult or prolonged weaning from IMV treatment
Trial design	Parallel group randomised controlled trial with internal pilot and cost effectiveness analysis
Participants	Adult ICU patients who are at risk of difficult or prolonged weaning from IMV
Planned sample size	900
Treatment duration	≤28 days
Follow-up duration	6 months following randomisation
Planned trial period	May 1 <sup>st</sup> 2024 to 31 <sup>st</sup> September 2028
Inclusion criteria	<ol style="list-style-type: none"> <li>1. Age 18 years or over</li> <li>2. Receiving invasive mechanical ventilation</li> <li>3. Expected to stay on IMV for ≥48hrs</li> <li>4. Any clinical risk factor for difficult or prolonged weaning from IMV</li> </ol>
Exclusion criteria	<ol style="list-style-type: none"> <li>1. Death or treatment withdrawal imminent within 48 hours</li> <li>2. Contraindication to nasogastric or orogastric tube insertion, such as upper airway or oesophageal trauma, bleeding or risk of bleeding due to recent surgery (e.g. oesophageal surgery), oesophageal varices and/or portal hypertension, and skull base fracture</li> <li>3. A temporary or permanent cardiac pacemaker (potential impact on the EDi signal)</li> <li>4. Phrenic nerve injury, Myasthenia Gravis or Guillain Barre Syndrome (potential impact on the EDi signal)</li> <li>5. Severe central neurologic disorder causing elevated intracranial pressure, impaired control of breathing, or requiring neuroprotective ventilation (e.g., traumatic brain injury)</li> </ol>

	<ol style="list-style-type: none"> <li>6. Known or suspected, severe or progressive neuromuscular disorder likely to result in prolonged or chronic ventilator dependence (e.g., Motor Neuron Disease, Duchenne Muscular Dystrophy, Amyotrophic Lateral Sclerosis, Multiple Sclerosis, spinal cord injury above C6, Kyphoscoliosis, or other restrictive disorder).</li> <li>7. Severe, end-stage, irreversible respiratory or cardiac disease with referral to a long-term weaning unit for likely chronic ventilator dependence, or referral to palliative care (e.g. severe irreversible pulmonary fibrosis or interstitial lung disease)</li> <li>8. Home ventilation prior to ICU admission, excluding nocturnal CPAP</li> <li>9. Previous participation in the UK NAVA trial</li> </ol>
Intervention	NAVA technology uses a specialised nasogastric/orogastric tube (NAVA catheter) to obtain the electrical activity of the diaphragm (EDi) muscle, which is a reliable index of the patient's respiratory drive. Once the NAVA catheter is placed, the EDi is always visible to clinicians, allowing optimisation of ventilator settings in any mode. When the NAVA mode is active, the ventilator triggers, cycles and adjusts support in synchrony and proportion to the EDi.
Control	Conventional invasive ventilator modes (no NAVA Technology)
Primary outcome	Duration of mechanical ventilation (time from randomisation to first successful unassisted breathing or death)
Secondary outcomes	<ol style="list-style-type: none"> <li>1. All-cause mortality at hospital discharge, 2 months and 6 months after randomisation</li> <li>2. Time to first successful extubation</li> <li>3. Reintubation prior to first successful unassisted breathing</li> <li>4. Use of non-invasive ventilation following extubation (prior to first successful unassisted breathing)</li> <li>5. ICU and hospital length of stay</li> <li>6. Serious adverse events up to hospital discharge</li> <li>7. Health related quality of life (EQ-5D-5L) at 2 months and 6 months after randomisation</li> <li>8. Acute health care use at 2 months and 6 months following randomisation</li> <li>9. Cost-effectiveness of NAVA compared to IMV at 6 months post-randomisation</li> </ol>
Statistical methods	<p>Primary analysis will be intention-to-treat.</p> <ol style="list-style-type: none"> <li>1. Primary analysis: Cox proportional hazard regression model will be used to estimate the treatment effect reporting hazards ratio and its 95% confidence interval (CI), using both unadjusted and adjusted analysis.</li> <li>2. Secondary analysis: Random effects models will be used depending on distribution of the outcomes. The unadjusted</li> </ol>

	<p>and adjusted treatment effects and its 95% CI will be reported.</p>
<p>Health economic methods</p>	<ol style="list-style-type: none"> <li>1. Primary analysis: A within-trial cost-effectiveness analysis comparing NAVA technology with usual care over a 6-month period.</li> <li>2. Secondary analysis: If the within-trial analysis indicates that NAVA has a long-term impact on costs and outcomes, and resources and timelines allow, an economic model will be developed to estimate its lifetime cost-effectiveness.</li> </ol>

## Abbreviations / glossary

---

Table 2. Abbreviations / glossary

ARDS	Acute Respiratory Distress Syndrome
CI	Confidence Intervals
COPD	Chronic Obstructive Pulmonary Disease
CoReCCT	Confederation of Respiratory Critical Care Trials
eCRF	Electronic Case Report Form
EDi	Electrical diaphragmatic activity measured in microvolts
ETT	Endotracheal tube
DMC	Data Monitoring Committee
HRQoL	Health-related Quality of Life
ICU	Intensive Care Unit
IMV	Invasive Mechanical Ventilation
ISRCTN	International Standard Registered Clinical/soCial sTudy Number
NAVA	Neurally Adjusted Ventilatory Assist
NAVA Technology	NAVA (neural drive) monitoring plus the NAVA ventilation mode
NIV	Non-invasive ventilation
PEEP	Positive-end expiratory pressure
PPI	Public and Patient Involvement
PSV	Pressure Support Ventilation
QALY	Quality Adjusted Life Year
RCT	Randomised Controlled Trial
RASS	Richmond Agitation Sedation Scale
R&D	Research and Development
REC	Research Ethics Committee
SAE	Serious Adverse Event
TMG	Trial Management Group
TSC	Trial Steering Committee
Vt	Tidal Volume

## 2 BACKGROUND

---

### 2.1 EPIDEMIOLOGY AND BURDEN OF THE CONDITION

Invasive mechanical ventilation (IMV) is associated with serious complications and costs, often directly relating to IMV duration [1]. In addition to prolonged physical discomfort and psychological distress, extended durations of IMV treatment increase the risk of infection, lung and muscle damage, and death [2]. About one-third of patients experience difficulties when reducing support (weaning), causing a prolonged duration of IMV [1]. For these reasons, optimised and efficient processes are critical [3].

Across the UK and internationally, the main method of weaning IMV involves use of Pressure Support Ventilation (PSV). Using PSV, the pressure delivered to the lungs during spontaneous breathing efforts is fixed and determined by clinicians based on clinical examination. An important limitation, however, is that the pressure and timing of breaths may not match patient need, which varies over time [4]. Moreover, due to the expertise and time required to set and manually adjust PSV, human factors such as limited staff and expertise can cause errors and delays [5]. These limitations may result in worse patient outcomes including difficult or prolonged IMV [4, 5].

In contrast, automated weaning technologies, such as NAVA, adapt the ventilator automatically according to continuously measured physiological parameters [5, 6]. Using NAVA technology, the electrical activity of the diaphragm (EDi) muscle is continuously measured using a special NAVA catheter. This activity can be used as a monitor of patient respiratory drive, allowing optimisation of ventilator settings in any mode. When the NAVA mode is active, the EDi signal triggers, cycles and adjusts ventilator support within each breath in proportion to diaphragm muscle activity [6].

### 2.2 EXISTING KNOWLEDGE

Many clinical studies confirm that the NAVA mode improves the synchrony between the ventilator support and the patient's breathing activity [7]. In the NAVA mode, the reduction in diaphragm electrical activity caused by increasing inspiratory assist (and vice versa) causes tidal volume to remain relatively stable over a wide range of ventilator assist. This physiological regulation and pulmonary reflex mechanisms prevent high tidal volumes and facilitate lung-protective ventilation [4]. The same mechanism prevents diaphragm inactivity due to over-assistance, as low diaphragm activity will immediately reduce inspiratory assist [8].

In relation to the effect of NAVA on mechanical ventilation duration (our primary outcome), systematic reviews by Wu (2022, 6 studies, 650 patients), Kampolis (2022, 4 studies, 327 patients) and Yuan (2021, 6 studies, 673 patients) found mean differences of -2.64 days (95% confidence interval (CI), -4.88 to -0.41;  $p = 0.02$ ), -4.89 days (95% CI -10.80 to 1.02;  $p = 0.10$ ), and -2.63 days (95% CI -4.22 to -1.03;  $p = 0.001$ ) respectively [9-11]. Larger reductions were seen in patients with risk factors for longer IMV duration [9], supporting our choice of effect size and inclusion criteria. Although these three meta-analyses suggest benefit in mechanical ventilation and other clinical outcomes, however, they also found low evidence certainty and inconsistency in trials.

### 2.3 PILOT FEASIBILITY TRIAL AND SURVEYS

To test the feasibility of our trial protocol, we conducted a randomised pilot feasibility trial ( $n=78$ ) [12], a detailed staff survey ( $n=301$ ) [13] and a national clinician survey (unpublished).

### **Pilot trial results summary**

The NAVA mode was initiated successfully in 31/34 (91%) intervention arm patients with median adherence (proportion of eligible weaning time spent in the NAVA mode) of 83.1% (64.0 to 97.1%). Diaphragm monitoring was active in all but one intervention arm patient. In secondary outcomes, the trial found more days free of ventilation at day 28 (median difference (MD) 3.0 days, 95% CI 0.0–11.0;  $p = 0.04$ ), fewer in-hospital deaths (relative risk 0.5, 95% CI 0.2–0.9;  $p = 0.032$ ) and a non-significant difference in mechanical ventilation duration (MD 3.0 days, 95% CI 0.4 to 8.6;  $p = 0.13$ ).

### **Staff survey results summary**

The survey was conducted shortly before the end of recruitment to the pilot trial, and explored attitudes, beliefs and barriers to NAVA Technology use and research. Of the 466 questionnaires distributed, 301 (64.6%) were returned including responses from 236 nurses (78.4%), 53 doctors (17.6%) and 12 physiotherapists (4.0%). In summary the survey found broad support for NAVA use, belief in safety and clinically efficacy, and support and equipoise for research. It also found a perception complexity compared with PSV, low confidence among users and a need for improved training. These findings have informed training materials, study documents and practical measures to improve the intervention and methods of our proposed study.

### **National survey results summary**

The national survey was conducted to understand the availability and use of NAVA and other automated ventilation technologies nationally, receiving responses from 163 ICU clinicians from 86 NHS hospitals (2021 unpublished data). In summary, one or more automated technologies were available at 63/86 (73.3%) responding hospitals and NAVA capable ventilators were available in 28/70 (40%) hospitals. Amongst clinicians working in hospitals with NAVA capable (Getinge) ventilators, 35/62 (56.5%) indicated experience with NAVA. Out of 130 clinicians who completed all survey questions, 81 (62.3%) would use NAVA if available and 41 (31.5%) were unsure; 111 (85.4%) agreed current evidence is uncertain; and 119 (91.5%) wanted more evidence. In relation to our proposed trial, 86 (66.2%) would definitely or probably recruit, 38 (29.2%) would possibly recruit or were unsure, and only 6 (4.6%) said that they would not recruit.

## 2.4 RESEARCH QUESTION

What is the clinical and cost-effectiveness of NAVA technology compared to conventional IMV, for patients at risk of difficult or prolonged weaning from invasive mechanical ventilation, as defined by the presence of a condition known to be associated with difficult or prolonged IMV weaning?

## 2.5 NEED FOR A TRIAL

The identification of effective treatments to shorten IMV treatment duration is a priority at this time due to escalating ICU bed pressures and diminishing staffing resources. Prior to the pandemic, up to 60% of UK ICUs did not meet locally agreed staffing numbers and 40% of ICUs closed beds at least once a week due to staff shortages, specifically nursing [14]. Automated technologies may mitigate the risks of sub-optimal weaning care due to continuing workforce issues. Despite the availability and use of NAVA in the NHS, knowledge and understanding of best practice to ensure optimal clinical effectiveness is lacking.

Due to the physiological, clinical and feasibility evidence described above, there have been calls for definitive clinical trials [5, 9] to address the uncertainty around clinical and cost-effectiveness of NAVA. The UK NAVA trial aims to address this knowledge gap with an adequately powered and rigorously trial

comparing NAVA technology to usual care. The trial also addresses a priority of the James Lind Alliance ICU priority setting partnership, 'What is the best way of preventing lung damage of patients receiving respiratory support?' [15].

## 2.6 CONFEDERATION OF RESPIRATORY CRITICAL CARE TRIALS

UK NAVA sits as one of four trial domains within the Confederation of Respiratory Critical Care Trials (CoReCCT). The confederation was established as a novel concept to group respiratory critical care trials with an overarching aim to streamline trial delivery across areas such as governance, contracting, and data collection. The overriding objective is to improve deliverability by minimising burden on participating sites and participants.

## 3 TRIAL DESIGN

---

### 3.1 TRIAL SUMMARY AND FLOW DIAGRAM

We will conduct a multi-centre, randomised, allocation concealed, controlled, open label, pragmatic, parallel group clinical and cost effectiveness trial with an internal pilot. The internal pilot will run for 6 months in 10 sites (with staggered starts to facilitate site initiation visits and site support). The internal pilot will use identical processes as the main trial and will assess site set-up, screening, participant recruitment, protocol adherence, and cross over rates. Progression criteria are outlined below. All participants included in the internal pilot will be included in the final analyses. The trial will be reported in line with the CONSORT (*Consolidated Standards of Reporting Trials*) statement. [16]

Once the pilot has been completed sites will be opened as soon as possible in a phased manner ideally over a 10-month period. It is expected around 30 more sites will be opened and recruitment is anticipated to continue for a total of 37 months.

#### **PICO summary**

Population: Critically ill adults receiving IMV and at risk of difficult or prolonged weaning

Intervention: NAVA Technology (NAVA monitoring and NAVA mode)

Comparator: Conventional invasive ventilator modes (no NAVA Technology)

Outcome: Duration of invasive mechanical ventilation from randomisation (primary clinical effectiveness), plus cost-utility at 6-months

**Figure 1.** Trial flow diagram

Study flow chart

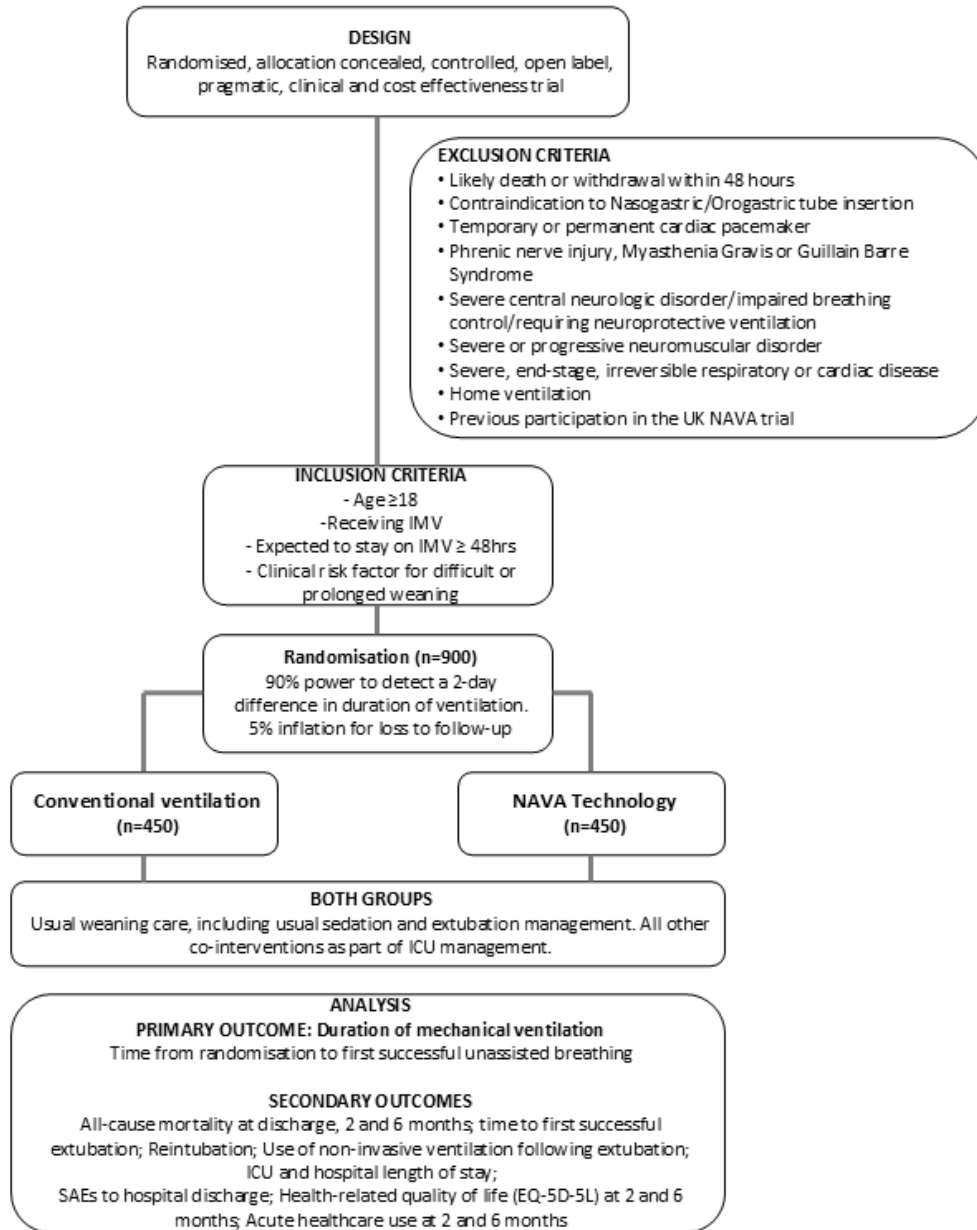

## 3.2 TRIAL SETTING

The UK NAVA trial will be conducted in approximately 40 ICUs across the UK. These will include university teaching hospitals and district general hospitals in both urban and rural settings. The ICUs must provide evidence that they have access to the trial population, that all consultants in the ICU have clinical equipoise for NAVA technology and agree to maintain trial allocation in patients randomised by their colleagues.

Staff must also demonstrate and document a willingness to comply with the protocol, standard operating procedures, the principles of Good Clinical Practice (GCP) and regulatory requirements and be prepared to participate in training. All new sites will be provided with education and mentoring on NAVA Technology during trial conduct from the research team.

## 3.3 INTERNAL PILOT

Our trial will include an internal pilot that will run for 6 months (months 6 to 12) with all participants recruited in the pilot included in final analyses. The pilot will take place in 10 representative sites with a staggered start and will recruit 40 patients. The internal pilot will establish our ability to recruit to target, protocol fidelity, treatment switching rates, and data collection completeness.

During the internal pilot, we will audit screening logs, recruitment rates, reasons for exclusion, protocol fidelity, and treatment switching rates. We will measure dataset completeness, including completeness of the primary outcome, which we anticipate should be >95% as this is routinely documented in the medical record of all ventilated patients.

We will use a traffic light system to guide progression as recommended in best practice guidelines. [17]

- Green - progress to main trial with review of screening logs and protocol and any barriers to recruitment addressed
- Amber - progress to main trial with ongoing site set-up, review of screening logs and protocol deviations, and protocol review where necessary
- Red - decision to progress to main trial made by the Trial Steering Committee (TSC) and the Health Technology Assessment (HTA) secretariat.

The Data Monitoring Committee (DMC), TSC, and HTA secretariat will review internal pilot data and make recommendations in terms of trial progression.

Total number of participants recruited is based on the recruitment rate and number of sites open during the pilot period. Where the internal pilot is successful with milestones achieved and subsequent trial progression, patients in the pilot will be included in the main analysis. Thresholds are based on a traffic light system [18]: Green (100%), Amber (50%-100%) and Red (<50%).

Table 3. Internal pilot outcomes

	Red	Amber	Green
Recruitment rate/site/month	<0.35	0.35-0.7	0.7
Number of sites opened	<5	5-9	10
Intervention training delivery (percent of open sites)	<50%	50%-100%	100%

Total number of participants recruited	<21	21-42	42
Cross-over (% of recruited)	>5	1-5	0

### 3.4 AIMS, OBJECTIVES AND ENDPOINTS

The trial aims to determine the clinical and cost effectiveness of NAVA technology (NAVA monitoring and NAVA mode) compared to conventional IMV in patients with risk factors for difficult or prolonged weaning from invasive mechanical ventilation.

We have included as our trial outcomes, the core outcome set for trials of interventions intended to modify IMV duration developed by members of our group [18].

#### 3.4.1 PRIMARY OBJECTIVE AND OUTCOME

Our primary objective is to determine the effectiveness of NAVA technology for reducing the duration of mechanical ventilation compared to conventional IMV.

Our primary outcome is duration of mechanical ventilation in days commencing at randomisation and discontinuing at first successful unassisted breathing or death.

Successful unassisted breathing is defined as breathing unassisted at 48 hours with no inspiratory support or extracorporeal lung support. Duration of assisted breathing includes time receiving extracorporeal lung support, invasive mechanical ventilation and non-invasive ventilation delivering volume or pressure support ventilation; **excludes** high-flow oxygen therapy and continuous positive airway pressure.

This definition was agreed through an international consensus process, involving clinician, researcher, patient and family representatives, and industry [18, 19]. This primary outcome was chosen with Public and Patient Involvement (PPI) input.

#### 3.4.2 SECONDARY OBJECTIVES AND OUTCOMES

Our secondary objectives are to determine the effect of NAVA technology compared to conventional IMV on the following:

- All-cause mortality (2 months and 6 months from randomisation)
- Time to first successful extubation
- Need for reintubation prior to achieving first successful unassisted breathing
- Use of non-invasive ventilation following extubation but prior to achieving first successful unassisted breathing
- Time to pressure support  $\leq 5$
- ICU and hospital length of stay
- Serious adverse events up to hospital discharge
- HRQoL at 2 months and 6 months from randomisation
- Acute health care use at 2 months and 6 months following randomisation
- Within-trial cost-utility analysis from an NHS hospital care perspective (see below)
- Safety endpoints (see also section 'Serious adverse events up to hospital discharge')
- Pre-specified complications including
  - Naso-gastric tube entering brain

- Naso-gastric tube positioned in lungs (unrecognised/not corrected)
- Traumatic nasogastric catheter insertion (oesophageal perforation)
- Traumatic nasogastric catheter insertion (nasal/pharyngeal bleeding)
- Aspiration of stomach contents into the lungs
- Pneumothorax
- Unplanned removal of ETT or Tracheostomy
- Unplanned removal of naso-gastric tube
- Unplanned removal of any other invasive/indwelling device
- Any pressure injury caused by naso-gastric catheter
- MRI scan performed with NAVA naso-gastric catheter in situ
- Reportable safety events that fall outside of those reported as trial outcomes

### 3.4.3 COST-EFFECTIVENESS OBJECTIVE

To estimate the cost-effectiveness of NAVA compared to conventional IMV.

## 3.5 TRIAL PARTICIPANTS

Patients who meet all the following inclusion criteria and none of the exclusion criteria are eligible to participate in the trial.

### 3.5.1 INCLUSION CRITERIA

- Age 18 years or over
- Receiving IMV
- Expected to stay on IMV for  $\geq 48$ hrs
- Any acute and/or chronic clinical risk factor for difficult or prolonged weaning from invasive ventilation\*

\*For guidance, acute clinical risk factors would include pneumonia, ARDS, septic shock, multiple organ failure, acute pancreatitis. Chronic risk factors would include history of heart failure, COPD, obesity. Patients should not be included if they are solely being kept ventilated whilst awaiting imaging, a procedure, after drug overdose or awaiting a test result. Further guidance is provided during training.

### 3.5.2 EXCLUSION CRITERIA

1. Death or treatment withdrawal imminent within 48 hours
2. Contraindication to nasogastric or orogastric tube insertion, such as upper airway or oesophageal trauma, bleeding or risk of bleeding due to recent surgery (e.g., oesophageal surgery), oesophageal varices and/or portal hypertension, or skull base fracture
3. A temporary or permanent cardiac pacemaker (potential impact on the EDi signal)
4. Phrenic nerve injury, Myasthenia Gravis or Guillain Barre Syndrome (potential impact on the EDi signal)
5. Severe central neurologic disorder causing elevated intracranial pressure, impaired control of breathing, or requiring neuroprotective ventilation (e.g. severe traumatic brain injury, refractory status epilepticus)
6. Known or suspected, severe or progressive neuromuscular disorder likely to result in prolonged or chronic ventilator dependence (e.g., Motor Neuron Disease, Duchenne Muscular Dystrophy,

Amyotrophic Lateral Sclerosis, Multiple Sclerosis, spinal cord injury above C6, Kyphoscoliosis, or other restrictive disorder).

7. Severe, end-stage, irreversible respiratory or cardiac disease with referral to a long-term weaning unit for likely chronic ventilator dependence, or referral to palliative care (e.g. severe irreversible pulmonary fibrosis or interstitial lung disease)
8. Home ventilation prior to ICU admission, excluding nocturnal CPAP
9. Previous participation in the UK NAVA trial

### 3.6 SCREENING

All ventilated ICU patients will be screened daily for eligibility by the ICU research nurses or medical staff. Each site will maintain a screening log which will include data on the numbers of patients meeting eligibility criteria but not entered into the trial, those that consent but are then not enrolled, numbers not meeting inclusion criteria, and reasons for non-enrolment. A fully anonymised patient level minimal dataset (including age, sex, ethnicity, and reasons for non-enrolment) will be recorded to establish an unbiased study population and for reporting according to the CONSORT statement [16].

### 3.7 CONSENT

It is the responsibility of each site Principal Investigator (PI) (or designee) to ensure that written informed consent is obtained for each participant. Consent may be obtained by the PI, or an appropriately trained member of the site team provided they are GCP trained, suitably qualified and experienced and have been delegated this duty by the PI on the delegation log.

Once a participant who initially lacks capacity, regains capacity, they will be informed about the trial and invited to consent to continue in the trial.

Consent should be obtained as per the processes detailed in section 4.2.3 of the CoReCCT master protocol.

### 3.8 RANDOMISATION

Participants will be randomised via randomly permuted blocks using an automated web-based system on a one-to-one basis, stratified by site and prior randomisation to another CoReCCT trial, using a computer-generated randomisation schedule managed by the Warwick CTU. We have selected a parallel group RCT design to minimise selection bias and ensure against accidental bias.

### 3.9 POST-RANDOMISATION WITHDRAWALS, EXCLUSIONS AND MOVES OUT OF REGION

Participants, or their consultee on their behalf, may request to be withdrawn from the trial at any time without prejudice. Those that choose to withdraw from the trial intervention will continue to be followed-up as per the trial protocol, unless consent for this is explicitly withdrawn by the participant (or consultee if the participant lacks capacity).

In the event that a participant is transferred to another hospital, intervention delivery will usually stop at the point of transfer. The recruiting hospital will liaise with the new hospital to facilitate collection of follow-up data.

In the event that a randomised participant is later found to be ineligible, they will continue to be followed-up and will be included in study analyses.

### 3.10 CO-ENROLMENT

The UK NAVA trial investigators will consider co-enrolment to other interventional trials outside of CoReCCT where there are no possible treatment interactions or conflict with the trial objectives. Co-enrolment agreements will be put in place on concurrently running trials. Co-enrolment will be permitted with non-interventional observational studies without the need for a co-enrolment agreement. Co-enrolment status will be collected using the eCRF. Co-enrolment will be managed in line with the approach agreed within the national critical care community.

### 3.11 MEASURES TO AVOID BIAS

The open-label design of this trial means that patients and clinicians are aware of treatment allocation. Although blinding was considered, during trial design meetings, this is not feasible as clinical teams cannot be blinded to ventilator settings. These and the patient response must be visible to guide clinical decision making and ensure patient safety. While lack of blinding can introduce bias, we have safeguards in place to mitigate against this risk as described below.

To mitigate against potential sources of bias with an open label design, we will:

- undertake source verification (from the electronic (or paper) medical record) to minimise the risk of reporting bias. The main clinical and resource utilisation outcomes of this study (e.g., ventilation duration, death, length of stay and adverse events) are recorded contemporaneously in the patient medical record by a member of the clinical team as part of routine documentation.
- use the duration of ventilation as our primary outcome as this is objectively measured and documented in the medical record. Other secondary outcomes are also objective; only health-related quality of life requires participant self-report.
- use a short duration of follow-up for the primary outcome (i.e., 48 hours to determine successful extubation) to minimise the risk of loss to follow-up and attrition bias. On the rare occasion that a patient or their representative chooses to withdraw, we will seek permission to retain data collected up until that point and to continue to collect the main outcome data. Our experience is that patients or their representatives normally are happy to proceed on this basis.
- monitor usual care in the standard care arm over the duration of the trial to decrease the likelihood of performance bias. We will provide additional training if required.
- collect measures of intervention fidelity over the duration of the trial. If poor fidelity is found, we will provide additional training and support to sites and continue to monitor fidelity. Sites with ongoing issues with intervention fidelity will be closed to recruitment.

We have selected outcomes and measures with demonstrated validity and reliability recommended in the core outcome set for trials of interventions to modify mechanical ventilation duration developed by members of our team (DMcA, Rose, Connolly) [18]. Health-related quality of life will be collected by blinded assessors independent of the clinical team involved in delivering the intervention.

We have used the SPIRIT guidelines and checklist to inform the development of our protocol [20]. We will register the trial and will make a full study protocol publicly available. To ensure our trial reporting is accurate, comprehensive, and transparent, we will use the CONSORT- reporting guidelines to report out

study findings [16]. We will document participant flow through the study, including screening, baseline and follow up assessments using a CONSORT flow diagram. To avoid selective reporting, we will report all outcomes as outlined a priori in our study protocol.

We will use University of Warwick standardised operating procedures for trial conduct.

### 3.12 SITE STAFF TRAINING

A programme of training will be provided to individuals at hospital sites with responsibility for the assessment of eligibility criteria and randomisation of participants. We will develop web-based training resources that enable site staff to complete training at a time convenient to them. If it is more convenient to specific individuals, training may be provided in person or via video conferencing. This training may be delivered by WCTU staff or by the site principal investigator, or a member of the site team that has been approved to deliver training by the principal investigator. Each hospital site will maintain a training completion log.

We will develop a bespoke training package for clinical members of staff that may be involved in using NAVA technology (See NAVA Technology Training).

## 4 INTERVENTIONS

---

### 4.1 INTERVENTION ARM (NAVA TECHNOLOGY)

We will compare NAVA Technology to conventional IMV. NAVA technology uses a specialised nasogastric/orogastric tube (NAVA catheter) to obtain the electrical activity of the diaphragm (EDi) muscle, which is a reliable index of the patient's respiratory drive. Once the NAVA catheter is placed and connected, the EDi is always visible to clinicians, allowing optimisation of ventilator settings in any mode. When the NAVA mode is active, the ventilator triggers, cycles and adjusts support in synchrony and proportion to the EDi.

There are two components of the UK NAVA trial intervention: NAVA EDi monitoring and The NAVA mode

Every patient who is randomised to the NAVA Technology arm must receive

1. NAVA catheter insertion (within six hours of randomisation)
2. Hourly EDi signal monitoring while receiving IMV (EDi $_{peak}$  and overlay of EDi Waveform on Pressure Time Waveform)
3. NAVA mode ventilation for weaning

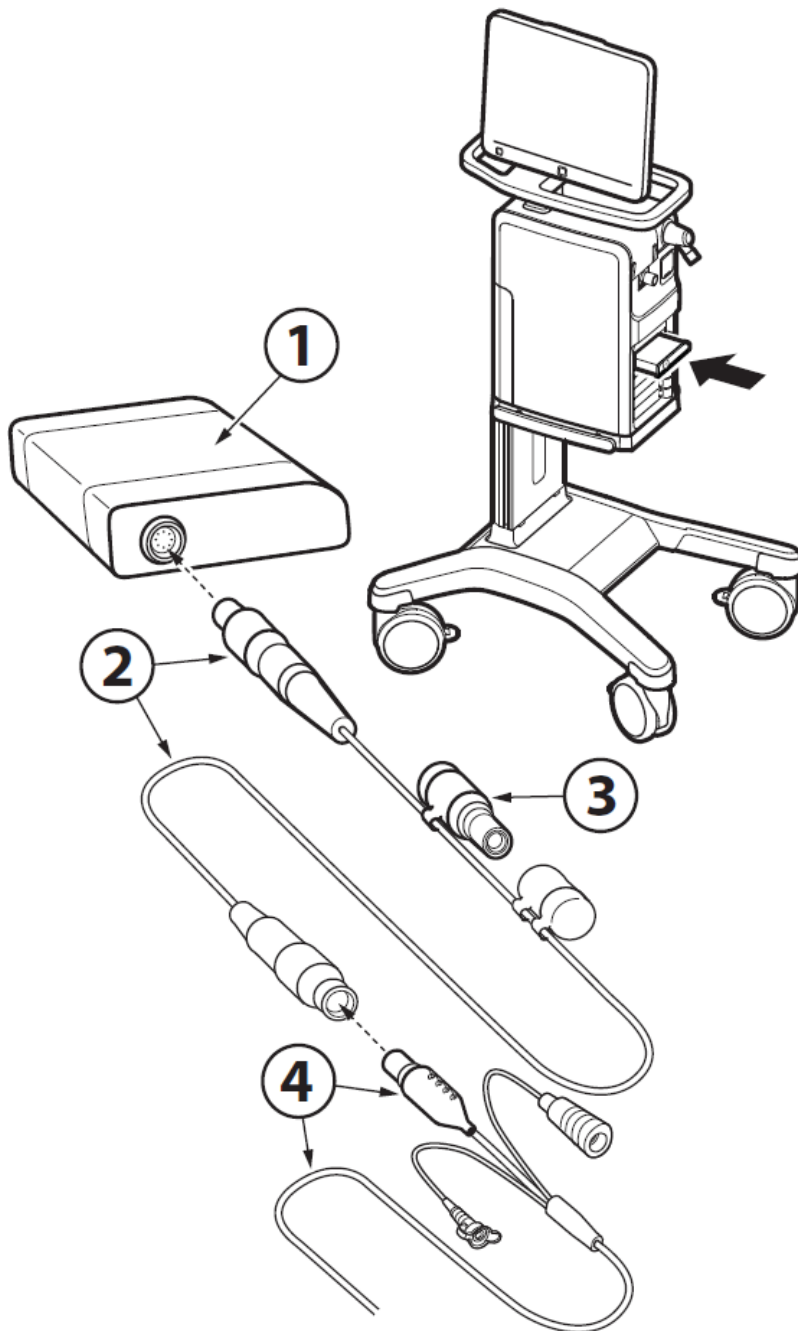

**Figure 2. NAVA system components:** EDi Module (1) EDi Cable (2) EDi Test Plug (3) NAVA Catheter (4). Adapted from NAVA User's Manual. Maquet Servo-i® ventilator system version 4.0. Maquet (Solna, Sweden).

#### 4.1.1 COMPONENT 1: EDI SIGNAL ACQUISITION AND OPTIMISATION

##### 4.1.1.1 NAVA CATHETER INSERTION

1. Select NAVA catheter:
2. 16 French: Patient height >140 cm (>55.1 in) French
3. 12 French: Patient height 75 to 160 cm (29.5 to 63.0 in) Connect the EDi module and cable

4. Perform the EDi module function check
5. Measure the NEX distance in cm
6. Determine the insertion distance (use on-screen calculator)
7. Dip the NAVA catheter in water and insert. Do not use silicone spray or other lubricants as the NAVA catheter is pre-lubricated. This may result in the NAVA catheter malfunctioning (Tip: cover with water while in the clear plastic tray packaging)
8. Connect the NAVA catheter to the ventilator via the EDi cable
9. Verify the position in the positioning window (Figure 3)
10. Secure the NAVA catheter to the patient
11. Document the insertion procedure and final insertion depth according to local practice. Enter the final insertion depth on the Servo-U
12. Check position for enteral feeding according to local policy. The ECG signal that is used to 'centre' the NAVA catheter does NOT confirm gastric placement. Training will emphasise that clinical teams are responsible for using standard safe practice for NGT placement and confirmation of gastric placement before enteral feeding or medications are commenced
13. Correct positioning using the positioning window should be verified every 12 hours

**Note 1:** There is no difference in procedure between placing a NAVA catheter and placing a regular naso-gastric feeding catheter. Placement should be performed by trained clinicians according to local guidelines. The ventilator positioning window positioning tool must NEVER be used to confirm gastric position prior to feeding

**Note 2:** NAVA catheters should be used as per the technical specifications within the EDi Catheter Datasheet [21]. After this time, catheters should be removed and replaced. See section 4.4 'NAVA Technology Intervention Duration' for further detail. Training will emphasise that patients should not be discharged to a ward with a NAVA catheter unless there is a clear and documented clinical justification and plan for follow-up.

**Note 3:** NAVA catheters should be removed from patients before transfer to non-Critical Care areas.

**Note 4:** NAVA catheters contain metal and are not approved for use in MRI environments. Catheters should be removed prior to MRI scanning. Catheters that are removed may be retained and reinserted.

#### 4.1.1.2 EDI OPTIMISATION

1. Open the NAVA catheter positioning window
2. Perform interventions to promote inspiratory effort if necessary \*
3. Make adjustments to the NAVA catheter position (insertion depth) to obtain the optimum diaphragmatic signal:
  - a. Pink highlighted second and third leads
  - b. Descending ECG signal amplitude
  - c. EDi signal corresponding to breathing activity

\* Patients may be switched from mandatory ventilation modes to PSV, NAVA or CPAP mode in order to promote spontaneous breathing. Other

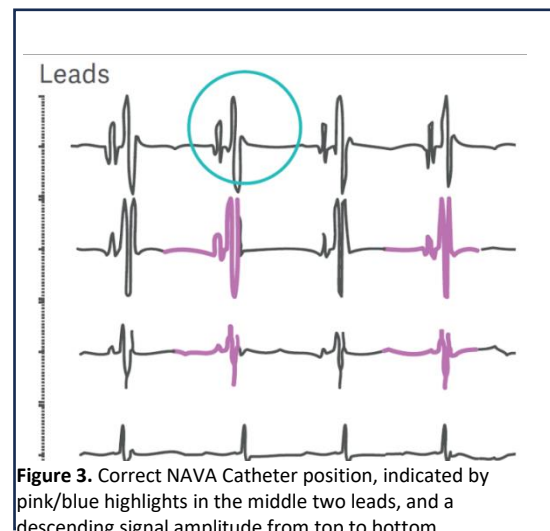

**Figure 3.** Correct NAVA Catheter position, indicated by pink/blue highlights in the middle two leads, and a descending signal amplitude from top to bottom

suggested interventions include sedation reduction, ventilation support reduction, or inspired oxygen reduction.

#### 4.1.2 COMPONENT 2: NAVA MONITORING

Electrical diaphragmatic activity (EDi) is displayed on the ventilator screen as a dynamic waveform and as stored trend data. The EDi peak represents maximal electrical activity of the diaphragm for a particular breath (measured in  $\mu\text{V}$ ). The EDi min represents the electrical activity of the diaphragm between inspiratory efforts (measured in  $\mu\text{V}$ ). This information may be used to optimise ventilator settings and sedation in any mode. In addition to usual ventilator observations, the following should be performed/recorded by clinical staff

1. EDi *peak* recorded hourly
2. Overlay of EDi waveform on Pressure waveform
3. NAVA Catheter position check to ensure optimal EDi signal (every 12 hours and prior to NAVA mode commencement)
4. EDi trend check as required

#### 4.1.3 COMPONENT 3: THE NAVA MODE

In the NAVA mode, pressure supported breaths are triggered, cycled and adjusted in proportion to the electrical activity of the diaphragm (EDi). The NAVA level (set by the clinician on the ventilator) is the amplification factor by which the EDi signal is multiplied to determine the level of assist to the patient (in  $\text{cmH}_2\text{O}$ ). The maximum pressure assist provided during a breath is: Peak pressure ( $\text{cmH}_2\text{O}$ ) = NAVA level x (EDi peak – EDi min) + PEEP. For example, if NAVA level is set to 1  $\text{cmH}_2\text{O}/\mu\text{V}$  with a peak EDi for a specific breath of 10  $\mu\text{V}$ , the maximum level of support delivered for that breath is 10  $\text{cmH}_2\text{O}$ . As with all modes, the maximal pressure will be limited to 10% below the set limit within the 'alarms' settings.

In the UK NAVA Trial, the NAVA mode should be used in place of the Pressure Support or Volume Support spontaneously triggered ventilation modes. An attempt to commence NAVA mode should be made at least once every 24 hours when clinically appropriate.

##### 4.1.3.1 NAVA MODE PREPARATION

1. To determine starting NAVA level, either:
  - a. Select NAVA level 1.0  $\text{cmH}_2\text{O}/\mu\text{V}$ , **OR**
  - b. Use the preview window to estimate the same or just below positive inspiratory pressure as delivered in the previous mode
2. Set back-up ventilation
3. Optimise the diaphragmatic EDi signal (minimise sedation)

##### 4.1.3.2 AFTER COMMENCEMENT: TITRATING AND OPTIMISING THE NAVA MODE

1. Titrate the NAVA level with the same principles used to titrate pressure support according to
  - a. Tidal volume, aiming for 6-8ml/kg predicted body weight
  - b. Respiratory rate
  - c. A visual assessment of breathing and patient comfort
2. Monitor for cardiovascular stability, desaturation, increased work of breathing, or tachypnea

#### 4.1.4 NAVA TECHNOLOGY TRAINING

All site staff will complete a training package appropriate to their role prior to opening to recruitment. The training package will include information on set up, optimisation, and weaning of the NAVA mode; and trouble shooting guides.

#### 4.2 STANDARD CARE ARM

Ventilation in the standard care arm will follow current best practice within the participating centres adhering to conventional lung protective ventilation. NAVA catheters must not be placed in Standard Care arm patients.

#### 4.3 BOTH GROUPS

##### 4.3.1 VENTILATOR WEANING

Weaning will be conducted according to the usual practices of the participating site (e.g., spontaneous breathing trial, stepwise reductions, periods of CPAP or T-Piece). There is a lack of consensus relating to the definition of weaning, however in general, criteria for readiness to wean as presented in the recent Weansafe international observational weaning trial (Lancet Respiratory, May 2023), comprise the following:

1.  $FiO_2 \leq 40\%$ ,  $PEEP \leq 8$  cmH<sub>2</sub>O
2. Systolic blood pressure > 90 mmHg
3. Vasoactive drugs reduced or unchanged over previous 24 h
4. Patient has acceptable breathing efforts
5. Improvement in underlying condition and no requirement for controlled ventilation

Site training will include a review of standard of care approaches for the management of ventilator weaning.

##### 4.3.2 STANDARD INDICATIONS TO INCREASE VENTILATION SUPPORT DURING WEANING

1. Increased anxiety
2. Reduced SpO<sub>2</sub> saturation (<88% or a drop of >5%)
3. Significant heart rate change or acute cardiac dysrhythmia
4. Signs of respiratory distress, including tachypnoea or new use of accessory muscles

##### 4.3.3 EXTUBATION

The decision to extubate will be that of the individual clinicians based on local experience and patient response

##### 4.3.4 OTHER CLINICAL MANAGEMENT

Responsibility for all other management decisions remains the responsibility of the attending physicians and ICU team. Measures such as prone positioning, continuous neuromuscular blockade infusion, inhaled pulmonary vasodilators, or referral for consideration of extracorporeal membrane oxygenation (ECMO) can be applied in either arm of the trial as per standard care in the UK.

## 4.4 INTERVENTION DURATION

The intervention (NAVA technology or conventional IMV) will continue until:

- 28 days after randomisation
- Successful unassisted breathing
- Study intervention-related serious adverse event
- Death or discontinuation of active treatment
- Person giving consent requests discontinuation of intervention
- NAVA equipment unavailable
- Clinical team decision to withdraw with documented justification, e.g., documented and clinically justified decision to permanently remove the NAVA catheter before the end of IMV

NAVA catheters should be used as per the manufacturer's technical specifications [21] . Where it is clinically appropriate and safe, NAVA catheters should be replaced once the specified duration has been reached. Use of individual NAVA catheters for longer than this is outside the trial protocol. Although this will not be reported as a protocol deviation, the clinical justification will be recorded.

## 4.5 INTERVENTION ADHERENCE AND TREATMENT SWITCHING

Each day, we will record the ventilator settings for participants. Adherence to NAVA Technology will be recorded on the eCRF. The statistical analysis plan will define adherence to the trial intervention.

As a minimum requirement, intervention arm patients must receive a NAVA catheter. Standard care arm patients must not receive a NAVA catheter. Cross-over will not be allowed. This will be monitored during the trial. If any site despite re-training continues to experience cross-over, the site will be closed to recruitment.

# 5 ASSESSMENTS AND DATA COLLECTION

Data collection will be restricted to variables required to define patient characteristics at enrolment, to monitor interventions received, to monitor adverse effects, to determine health-related quality of life after hospital discharge, to capture the use of hospital healthcare resource and healthcare resource utilisation after hospital discharge. To ensure accurate, complete and reliable data are collected, the research team will provide training to site staff during investigator meetings and site initiation visits. The CTU will provide the PI and research staff with training on the protocol, CRF completion and trial procedures including standard operating procedures (SOPs).

Core baseline variables will be collected once and shared across the relevant domains of CoReCCT. These, and other data management details can be found in sections 6 and 10 of the CoReCCT master protocol. In addition to the core dataset, items related to the NAVA-specific outcomes will be collected.

## 5.1 TRIAL PROCEDURES SCHEDULE

Table 4. Data collection schedule

	Baseline	Intervention end	Up to ICU dx	Up to hospital dx	2 months	6 months
--	----------	------------------	--------------	-------------------	----------	----------

Screening for eligibility	X					
Consent details	X					
Baseline data collection	X					
Randomisation	X					
Ventilator settings, sedation use, organ failure		x				
Adverse events		x	X	X		
Primary & secondary outcomes		x	X			
Mortality (secondary outcome)			X	X	X	X
HrQoL (secondary outcome)					X	X
Healthcare utilisation after dx					X	X

## 5.2 FOLLOW UP PROCEDURES

Full details on follow up data collection procedures can be found in Section 6.5 of the CoReCCT master protocol.

## 6 SAFETY AND ADVERSE EVENTS

In order to accurately assess and report SAEs relevant to NAVA, the CoReCCT Master Protocol must be read in conjunction with section 4.1 below. Section 7 of the CoReCCT Master Protocol describes the CoReCCT Safety Reporting Flowchart and provides details on these adverse event management topics:

- Definitions of SAEs
- Assessing and reporting SAEs
- Causality Assessment of SAEs
- Expectedness Assessment of Related SAEs
- Expedited Reporting of Related and Unexpected SAEs to REC

### 6.1 PRE-SPECIFIED COMPLICATIONS

As per the CoReCCT Safety Reporting Process (Section 7 of the CoReCCT Master Protocol), adverse events that, 1) occur at sites between randomisation and hospital discharge and 2) are not present on the CoReCCT Exemption List, must be reviewed for their presence on the NAVA Pre-Specified Complications List as given below:

- Related to naso-gastric catheter placement;
  - a. Naso-gastric tube entering brain
  - b. Naso-gastric tube positioned in lungs (unrecognised/not corrected)
  - c. Traumatic nasogastric catheter insertion (oesophageal perforation)
  - d. Traumatic nasogastric catheter insertion (nasal/pharyngeal bleeding)
  - e. Aspiration of stomach contents

- f. Pneumothorax
- Other
  - a. Unplanned removal of ETT or Tracheostomy
  - b. Unplanned removal of naso-gastric tube
  - c. Unplanned removal of any other invasive/indwelling device
  - d. Any pressure injury caused by naso-gastric catheter
  - e. MRI scan performed with NAVA naso-gastric catheter in situ (NAVA catheters are MRI unsafe due to potential harm from movement or the generation of heat in the metallic electrodes. They may also cause artifacts in the MRI images.)

The events listed above must be entered onto the eCRF when appropriate as outcomes of interest, and therefore are exempt from SAE reporting. If an event occurs which does not appear either on the CoReCCT Exemption List or on the NAVA pre-specified complication list above, it must be assessed for seriousness, and the remainder of the CoReCCT safety reporting process should be followed to determine the next steps to be taken. Pre-specified complications will be collected onto the eCRF for the duration of the trial intervention up to 28 days. Any occurrence following this will be reported via the safety reporting process described in Section 7 of the CoReCCT Master Protocol.

## 6.2 EXPECTED EVENTS

SAEs which are considered possibly related, probably related or definitely related to the study intervention will be assessed for expectedness by a delegate of the Sponsor. This expectedness assessment may be supported by items such as, but not limited to; associated domain working instructions; published literature; and the following list of events which details events previously documented in relation to the intervention.

## 6.3 REPORTING RESPONSIBILITIES SUMMARY

All SAE/SADE/UADs need to be reported via the CDMS to the trial team within one working day of the site investigator team becoming aware of them. Reports of related and unexpected SAEs should be submitted to ethics by a delegated staff member at University of Warwick within 15 days of the Chief Investigator becoming aware of the event.

All reporting to the sponsor should have as much information about the incident as possible and following the causality assessment, will be signed by the Chief Investigator or Co-investigator. The sponsor will undertake a review of the information. Events will be followed up until resolution, any appropriate further information will be sent by the research team in a timely manner.

The Manufacturer has a legal obligation to report all events that need to be reported to the Nominated Competent Authority immediately (without any unjustifiable delay) after a link is established between the event and the device, but no more than:

- 2 days following the awareness of the event for Serious Public Health Threat.
- 10 days following awareness of the event for Death or unanticipated serious deterioration in health.
- 30 days following the awareness of the event for all other event meeting the SAE criteria.

## 7 DATA MANAGEMENT

---

Full details on data management are provided in sections 6 and 10 of the CoReCCT master protocol.

### 7.1 DATA COLLECTION AND MANAGEMENT

Full details are listed in section 10 of the CoReCCT Master Protocol.

### 7.2 DATA SHARED WITH THIRD PARTIES

Full details are listed in section 12 of the CoReCCT Master Protocol.

### 7.3 ARCHIVING

Full details are listed in section 13 of the CoReCCT Master Protocol.

## 8 STATISTICS AND HEALTH ECONOMICS

---

### 8.1 SAMPLE SIZE CALCULATION

The trial will recruit a total of 900 (450 per arm) participants (using 90% power, 5% significance level, and 5% loss to follow-up) to detect effect size of 2-days reduction in duration of MV. The parameter estimates for this study have been derived as follows:

1. **Effect size of 2-days reduction:** Given previous meta-analyses showed a reduction of MV duration with NAVA Technology of between 2.6 and 4.9 days [9-11], an effect size of 2 days is conservative and can be realistically achieved.
2. **Median duration of ventilation on the standard care arm:** Reported MV duration varies from 7 to 14 days in UK studies (i.e., 4.5 days- BREATHE study [22]; 14.1 days -OSCAR trial [23]). Amongst patients ventilated >48 hours (UK NAVA inclusion criteria), a commissioned report on 2018 and 2019 ICU admissions (ICNARC) and a recent, large international study [24] (Weansafe, Lancet Respiratory, May 2023) found median (IQR) MV durations of 6 days (4 to 11) and 7 days (4 to 12) respectively. To allow for any uncertainties and differences in the population, we have taken a more conservative estimate of 10 days for our sample size calculations.
3. **Loss to follow-up:** In the previous ICU studies, loss to follow-up ranges from 0% to 3% (1.1% - BREATHE [32]; 0% - OSCAR [33]; 0.4% - HARP-2 [35]; 3% - REST [36]). We have used a conservative estimate of 5% as our loss to follow-up rate.

### 8.2 STATISTICAL ANALYSIS

The trial results will be reported in accordance with the Consolidated Standards of Reporting Trials (CONSORT) [16]. Primary analysis will be intention-to-treat. For our primary analysis, a cox-proportional hazard model will be used to estimate hazard ratio with 95% confidence interval (CI). If the proportional hazard assumption is not valid, we will run a sensitivity analysis by fitting a mixed effects partially proportional hazards regression model with censoring for deaths and loss to follow-up. Although death in ICU may be considered a competing event, censoring for deaths allows us to estimate the instantaneous risk of experiencing a successful extubation event at time t given that the patient is

still alive at time  $t$  (known as “cause-specific hazard” of extubation for patients who have not yet died). Sites will be included in the model as a random effect, and treatment arm as a fixed effect. For secondary outcomes including quality-of-life measures which are continuous, mixed-effect linear regression models will be used to estimate the treatment effect with 95% CI. For secondary outcomes which are binary, mixed-effect logistic regression models will be used to estimate the treatment effect with 95% CI. We will explore different approaches that allow incorporation of multiple relevant outcomes including death into a single overall measure (e.g., win ratio [25]). A detailed statistical analysis plan will be agreed with the data monitoring committee.

### 8.3 SUB-GROUPS

We will examine the following subgroups:

- Neurological condition as the primary reason for ICU admission
- Duration of ventilation prior to randomisation: <48 hours and  $\geq 48$  hours; <7 days and  $\geq 7$  days
- Mode of ventilation at randomisation: Controlled/Mandatory mode versus spontaneous mode

These subgroup analyses will be performed using intention to treat. We will use the primary outcome as the dependent variable and interaction with treatment and sub-group. We will use linear regression models to assess the subgroup effect, using interaction terms. As these analyses are post-hoc analyses not powered for any effect size. Emphasis will be placed on the point estimates and 95% CIs, rather than the statistical testing.

### 8.4 FUTILITY ANALYSES

The methods for futility analyses and determining futility boundaries which account for censored observations are very limited in the literature. Assuming there is no censoring (and for every patient, an event will be observed), we can use normal approximation methods for the log hazard ratio. This assumption is reasonable in the context of this study. In consultation with the DMC, we aim to plan for a futility analysis halfway through our trial (at 50% sample size). We will use the conventional conditional power boundaries at this interim point, where we will declare for futility if the conditional power is <15%. Assuming our hazard ratio is 1.25 (as per the sample size), this interim analysis (and boundaries) does not impact on the overall study power of 90%. This futility rule will be used as a guidance criterion by the DMC. The decision to stop will be based largely on clinical judgement of all the outcomes, as well as parameters that drive operational futility (recruitment).

### 8.5 HEALTH ECONOMIC EVALUATION

A within-trial cost-utility analysis (CUA) will be conducted to assess the cost-effectiveness of Neurally Adjusted Ventilatory Assist (NAVA) technology compared to conventional invasive mechanical ventilation (IMV) over a six-month period from an NHS and Personal Social Services perspective, as recommended by NICE [26]. The primary economic outcome will be quality-adjusted life years (QALYs) derived from EQ-5D-5L utility scores collected at key follow-up points [27].

#### **Cost and Resource Use Data Collection**

Patient-level data on healthcare resource use will be collected using a trial-adapted costing questionnaire and supplemented with electronic case report forms (eCRFs), Hospital Episode Statistics (HES), and

Intensive Care National Audit & Research Centre (ICNARC) data, where available. Key cost components will include:

- Intervention costs: NAVA technology acquisition, consumables (e.g., NAVA catheter costs), staff training, and device maintenance.
- Hospital-based care: ICU and hospital length of stay, inpatient admissions, outpatient visits, and emergency department attendances.
- Community and social care: GP visits, community-based rehabilitation services, and social worker support.

All costs will be reported in GBP (£) using the latest NHS Reference Costs [28] and Unit Costs of Health and Social Care compendium [29].

### **Economic Analysis Approach**

Incremental cost-effectiveness ratios (ICERs) will be calculated by comparing differences in costs and QALYs between NAVA and IMV. Deterministic and probabilistic sensitivity analyses will be performed, with cost-effectiveness acceptability curves (CEACs) [30] generated to assess the probability of cost-effectiveness at different willingness-to-pay thresholds.

### **Decision Modelling (if applicable)**

If the within-trial analysis indicates that NAVA has a long-term impact on costs and outcomes, and resources and timelines allow, an economic model will be developed to estimate its lifetime cost-effectiveness. The modelling approach will be selected following the revised Brennan's taxonomy [31], incorporating transition probabilities and long-term outcomes where possible.

Further details and full descriptions of analyses will be given in the Health Economics Analysis Plan.

## 9 PROTOCOL COMPLIANCE

---

A study related deviation is a departure from the ethically approved study protocol or other study document or process (e.g. consent process or administration of study intervention) or from Good Clinical Practice (GCP) or any applicable regulatory requirements. Any deviations from the protocol will be documented in a protocol deviation form in the eCRF.

Exceptions to non-compliance reporting: in the event that NAVA catheters are not changed as per the manufacturer's technical specification, as indicated by the protocol, where to do so would pose a safety risk to the participant. These will be monitored on the eCRF and by the TMG.

If a NAVA catheter is replaced by a non-NAVA catheter before the end of IMV with documented clinical justification, this will be considered a clinical intervention withdrawal.

## 10 SUB-STUDY

---

Dyspnoea is a distressing and frequent symptom that is often associated with ventilator settings and worse patient outcomes [32]. Dyspnoea is also one of the most common symptoms experienced by people who are nearing the end of life. As the NAVA ventilation mode improves the synchronisation between patient breathing activity and ventilator support, it may also reduce the risk of dyspnoea [33]. NAVA monitoring may also help to identify dyspnoea and to assess the effect of interventions, such as

palliative treatment [34]. Due to the pragmatic design of this trial, and the challenges of dyspnoea assessment in mechanically ventilated and sedation patients, we will investigate dyspnoea in a sub-set of sites.

The sub-study will be fully described in an appendix to this protocol document.

## 11 DISSEMINATION AND PUBLICATION

---

Full details are listed in section 11 of the CoReCCT Master Protocol.

## 12 TRIAL ORGANISATION AND OVERSIGHT

---

### 12.1 SPONSOR AND GOVERNANCE ARRANGEMENTS

The University of Warwick will act as trial sponsor. Full details are listed in section 9.1 of the CoReCCT Master Protocol.

### 12.2 ETHICAL APPROVAL

Full details are listed in section 9 of the CoReCCT Master Protocol.

### 12.3 TRIAL REGISTRATION

We will prospectively register the trial with an appropriate trial registry.

### 12.4 NOTIFICATION OF SERIOUS BREACHES TO GCP AND/OR TRIAL PROTOCOL

Full details are listed in section 9.5 of the CoReCCT Master Protocol.

### 12.5 INDEMNITY

Full details are listed in section 9.6 of the CoReCCT Master Protocol.

### 12.6 TRIAL TIMETABLE AND MILESTONES

The total planned project duration is 52 months. A summary of key trial milestones is shown below.

**Table 5:** Project Milestones

	Month	Recruitment
Set-up	1-5	N/A
Internal Pilot	6-12	42
Recruitment	13-39	858
Follow up	40-45	N/A
Analysis, reporting & dissemination	46-52	N/A

## 12.7 ADMINISTRATION

The trial co-ordination will be based at WCTU, University of Warwick. Full details are listed in section 9.7 of the CoReCCT Master Protocol.

## 12.8 TRIAL MANAGEMENT GROUP (TMG)

Full details are listed in section 9.9 of the CoReCCT Master Protocol.

## 12.9 TRIAL STEERING COMMITTEE (TSC)

Full details are listed in section 9.11 of the CoReCCT Master Protocol.

## 12.10 DATA MONITORING COMMITTEE (DMC)

Full details are listed in section 9.10 of the CoReCCT Master Protocol.

## 12.11 ESSENTIAL DOCUMENTATION

Full details are listed in section 9.14 of the CoReCCT Master Protocol.

## 12.12 FINANCIAL SUPPORT

The trial has been funded by a grant from the National Institute of Health and Care Research Health Technology Assessment programme (NIHR155119). Full details are listed in section 9.13 of the CoReCCT Master Protocol.

## 12.13 SAFEGUARDING RESEARCHERS AND RESEARCH PARTICIPANTS

Full details are listed in section 9.15 of the CoReCCT Master Protocol.

## 13 REFERENCES

---

1. Béduneau, G., et al., *Epidemiology of Weaning Outcome according to a New Definition. The WIND Study*. American Journal of Respiratory and Critical Care Medicine, 2017. **195**(6): p. 772-783.
2. Goligher, E.C., et al., *Lung- and Diaphragm-Protective Ventilation*. American Journal of Respiratory and Critical Care Medicine, 2020. **202**(7): p. 950-961.
3. Blackwood, B., et al., *Protocolized versus non-protocolized weaning for reducing the duration of mechanical ventilation in critically ill adult patients*. Cochrane Database Syst Rev, 2014(11): p. Cd006904.
4. Jonkman, A.H., et al., *Proportional modes of ventilation: technology to assist physiology*. Intensive Care Medicine, 2020. **46**(12): p. 2301-2313.
5. Rose, L., et al., *Automated versus non - automated weaning for reducing the duration of mechanical ventilation for critically ill adults and children*. Cochrane Database of Systematic Reviews, 2014(6).
6. Sinderby, C., et al., *Neural control of mechanical ventilation in respiratory failure*. Nat Med, 1999. **5**(12): p. 1433-6.
7. Pettenuzzo, T., et al., *Effect of Neurally Adjusted Ventilatory Assist on Patient-Ventilator Interaction in Mechanically Ventilated Adults: A Systematic Review and Meta-Analysis*. Crit Care Med, 2019. **47**(7): p. e602-e609.
8. Goligher, E.C., et al., *Clinical strategies for implementing lung and diaphragm-protective ventilation: avoiding insufficient and excessive effort*. Intensive Care Med, 2020. **46**(12): p. 2314-2326.
9. Yuan, X., et al., *Neurally adjusted ventilatory assist as a weaning mode for adults with invasive mechanical ventilation: a systematic review and meta-analysis*. Crit Care, 2021. **25**(1): p. 222.
10. Wu, M., et al., *Neurally Adjusted Ventilatory Assist vs. Conventional Mechanical Ventilation in Adults and Children With Acute Respiratory Failure: A Systematic Review and Meta-Analysis*. Frontiers in Medicine, 2022. **9**.
11. Kampolis, C.F., et al., *Comparison of advanced closed-loop ventilation modes with pressure support ventilation for weaning from mechanical ventilation in adults: A systematic review and meta-analysis*. Journal of Critical Care, 2022. **68**: p. 1-9.
12. Hadfield, D.J., et al., *Neurally adjusted ventilatory assist versus pressure support ventilation: a randomized controlled feasibility trial performed in patients at risk of prolonged mechanical ventilation*. Crit Care, 2020. **24**(1): p. 220.
13. Hadfield, D., et al., *Factors affecting the use of neurally adjusted ventilatory assist in the adult critical care unit: a clinician survey*. BMJ Open Respiratory Research, 2020. **7**(1): p. e000783.
14. Endacott, R., et al., *The organisation of nurse staffing in intensive care units: a qualitative study*. 2022, medRxiv.
15. Reay, H., N. Arulkumaran, and S.J. Brett, *Priorities for Future Intensive Care Research in the UK: Results of a James Lind Alliance Priority Setting Partnership*. Journal of the Intensive Care Society, 2014. **15**(4): p. 288-296.
16. Moher, D., et al., *CONSORT 2010 Explanation and Elaboration: updated guidelines for reporting parallel group randomised trials*. BMJ, 2010. **340**: p. c869.
17. Avery, K., et al., *Informing efficient randomised controlled trials: exploration of challenges in developing progression criteria for internal pilot studies*. BMJ Open Respir Res, 2017. **7**: p. e013537.
18. Blackwood, B., et al., *A Core Outcome Set for Critical Care Ventilation Trials*. Crit Care Med, 2019. **47**(10): p. 1324-1331.
19. Blackwood, B., et al., *A Core Outcome Set for Critical Care Ventilation Trials*. Critical Care Medicine, 2019. **47**(10): p. 1324-1331.

20. Chan, A.W., et al., *SPIRIT 2013 statement: defining standard protocol items for clinical trials*. *Ann Intern Med*, 2013. **158**(3): p. 200-7.
21. Getinge. *Edi catheter ENFit Datasheet*. Available from: [https://www.getinge.com/dam/hospital/documents/english/servo-u-n-i-nava-datasheet-edi-catheter-enfit-mx-7028-en-non\\_us.pdf](https://www.getinge.com/dam/hospital/documents/english/servo-u-n-i-nava-datasheet-edi-catheter-enfit-mx-7028-en-non_us.pdf).
22. Perkins, G.D., et al., *Effect of Protocolized Weaning With Early Extubation to Noninvasive Ventilation vs Invasive Weaning on Time to Liberation From Mechanical Ventilation Among Patients With Respiratory Failure: The Breathe Randomized Clinical Trial* *Effect of Protocolized Noninvasive vs Invasive Weaning on Time to Liberation From Ventilation*. *JAMA*, 2018. **320**(18): p. 1881-1888.
23. Young, D., et al., *High-frequency oscillation for acute respiratory distress syndrome*. *N Engl J Med*, 2013. **368**(9): p. 806-13.
24. Pham, T., et al., *Weaning from mechanical ventilation in intensive care units across 50 countries (WEAN SAFE): a multicentre, prospective, observational cohort study*. *The Lancet Respiratory Medicine*, 2023. **11**(5): p. 465-476.
25. Pocock, S.J., et al., *The win ratio: a new approach to the analysis of composite endpoints in clinical trials based on clinical priorities*. *Eur Heart J*, 2012. **33**(2): p. 176-82.
26. National Institute for Health and Care Excellence. *Guide to the methods of technology appraisal 2013. Process and methods [PMG9]*. 2013; Available from: <https://www.nice.org.uk/process/pmg9/chapter/foreword>.
27. Brooks, R., *EuroQol: the current state of play*. *Health Policy*, 1996. **37**(1): p. 53-72.
28. NHS England. *National Cost Collection for the NHS*. 2020/2021; Available from: <https://www.england.nhs.uk/costing-in-the-nhs/national-cost-collection/>.
29. Jones, K.C., Weatherly, H., Birch, S., Castelli, A., Chalkley, M., Dargan, A., Forder, J.E., Gao, J., Hinde, S., Markham, S., Ogunleye, D., *Unit costs of health and social care 2022 manual*. 2023, Personal Social Services Research Unit: Canterbury.
30. Briggs, A.H., *A Bayesian approach to stochastic cost-effectiveness analysis*. *Health Econ*, 1999. **8**(3): p. 257-61.
31. Jin, H., et al., *Overview and Use of Tools for Selecting Modelling Techniques in Health Economic Studies*. *Pharmacoeconomics*, 2021. **39**(7): p. 757-770.
32. Demoule, A., et al., *Dyspnoea in acutely ill mechanically ventilated adult patients: an ERS/ESICM statement*. *European Respiratory Journal*, 2024. **63**(2): p. 2300347.
33. Demoule, A., et al., *Neurally adjusted ventilatory assist as an alternative to pressure support ventilation in adults: a French multicentre randomized trial*. *Intensive care medicine*, 2016. **42**(11): p. 1723 - 1732.
34. Hadfield, D., et al., *The use of neural monitoring to assist decision-making in terminal extubation or terminal weaning as part of end of life care in a critical care setting*. *ESICM LIVES 2017 : 30th ESICM Annual Congress. September 23-27, 2017*. *Intensive Care Medicine Experimental*, 2017. **5**(Suppl 2): p. 44.