

Turtlestitch Maths

Finding missing angles on a straight line

A key element of stitching shapes is working out how many degrees the turtle needs to turn.

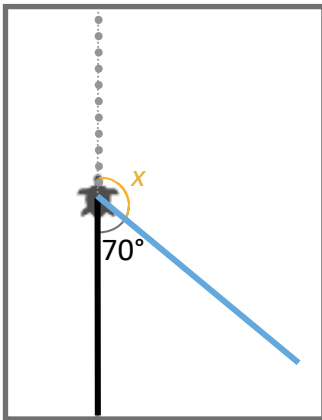

The turtle has already walked along the black line. The dots show where the turtle will go if you don't tell it to turn.

We want the turtle to walk along the blue line. To do this, how far does it need to turn?

What fact can you use to work out the missing angle?

1. Calculate the values of the missing angles.

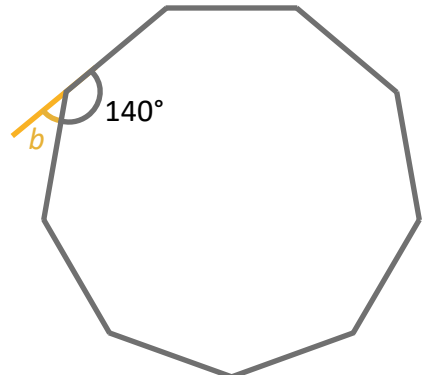
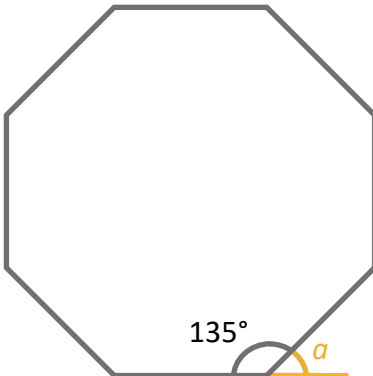

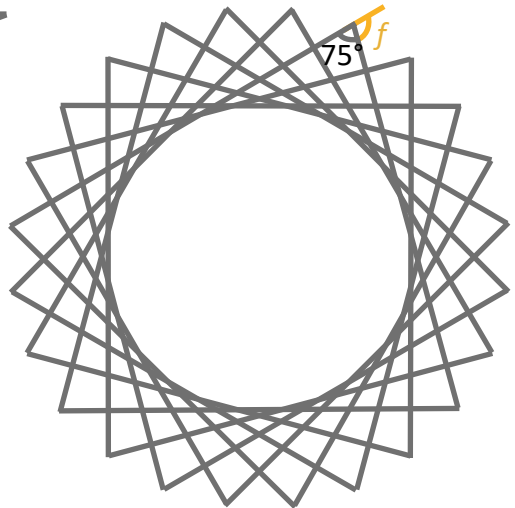
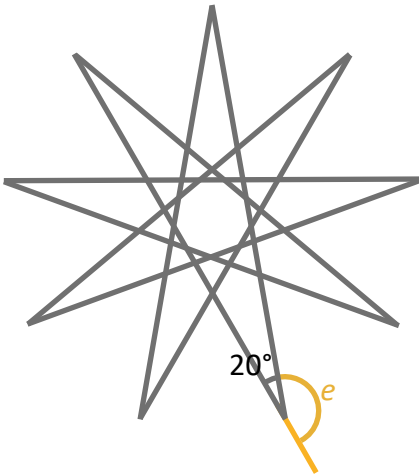
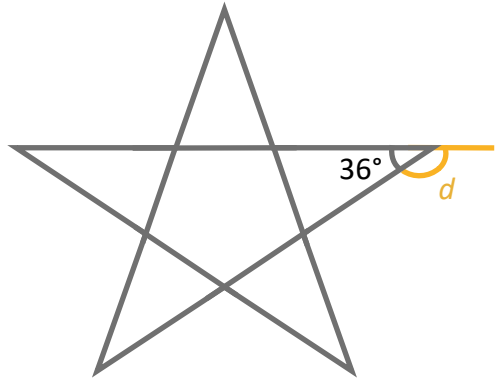
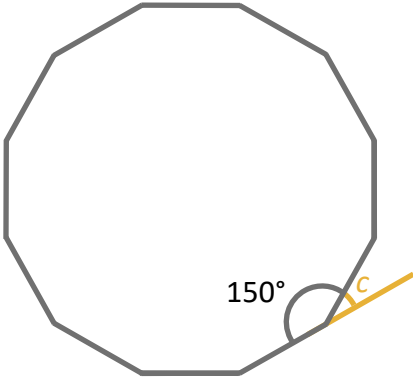

2. Using what you have found out, stitch the shapes on Turtlestitch with these blocks. How can you work out the number of repetitions?

reset
running stitch by 10 steps
repeat
move steps
turn degrees